

# Typology of Wood Joint Geometry in Basemah Highland Vernacular Architecture, South Sumatra, Indonesia

Iwan M Ibnu<sup>1</sup>, Ari Siswanto<sup>1</sup>, Yulianto P. Prihatmaji<sup>2,\*</sup>, Setyo Nugroho<sup>1</sup>

<sup>1</sup> Sriwijaya University, Palembang, Indonesia

<sup>2</sup> Universitas Islam Indonesia, Yogyakarta, Indonesia

\* Corresponding Author: [prihatmaji@uii.ac.id](mailto:prihatmaji@uii.ac.id)

## Abstract

Ghumah Baghi is the vernacular architecture of the Basemah highland, South Sumatra, Indonesia with distinctive wooden joints. Wood joint categories are divided based on geometry and arrangement, form, position, direction, move or no move, assembly, flush or not flush, additional reinforcement, component change, and resistance to loads. The problem of this study was: what types of wood joints were used in the construction of Ghumah Baghi? This study aimed to discover the typology and variations of joints based on geometry and arrangement. This study used a descriptive qualitative case study method. The data were collected through documentation, interview, and direct observation, and the analysis was carried out by comparing the types of wood joints from the literature. The research findings showed that there were 8 types and 36 variations of wood joints based on the theirition, shape, and unique geometry. Wood joints are affected by the availability of materials, geographical conditions, and assembly. Based on the typology of the wood joints, Ghumah Baghi construction is a knock-down construction resistant to earthquakes. This study was an initial study of making a prototype of an earthquake-resistant, knock-down house based on the structure and construction of Ghumah Baghi.

Keywords: *typology; wood joints; Ghumah Baghi*

## 1. INTRODUCTION

Vernacular architecture is architecture that is local, primitive, unattractive, and unfit to be preserved but has traditional building methods, technological sophistication, and structures and uses local materials to produce communal representations in buildings and settlements (Lodson et al., 2018, p. 84), so that it can be an indicator of the cultural diversity of ethnic groups that have philosophies and aesthetic values (Puspitasari & Lakawa, 2020, p. 1415), which is an important part of the architectural heritage that reveals the world's cultural diversity (Martynenko, 2017, p. 15).

Vernacular architectural classification focuses on local aesthetics as cultural influences and construction capabilities (Kassim et al., 2019, p. 340). Some typologies that are relevant to vernacular architecture are the elevation typology in the form of the scalar dimensions of the building cover, the shape typology to describe the volumetric character of the building, the floor plan typology which has a close relationship with the elevation and shape of the building, the spatial relationship typology that reflects the socio-cultural complexity and the structural typology creating space and form of buildings from materials and structural systems (Oliver, 1997, p. 610).

The typology of structures in vernacular architecture is based on the use of materials and structural systems so joints are important in traditional wooden structures because the safety and behavior of wooden structures are highly dependent on the performance of the joints (Feio et al., 2014, p. 213) (Poletti et al., 2016, p. 322). The response of traditional wood joints depends on compression and

friction of the joints between the elements and the manual manufacturing process allows for irregularities and gaps that will affect joint performance (Poletti et al., 2016, p. 323). Variations in the mechanical performance of wood joints depend on the carpenter, tradition, geography, and climate (Chang et al., 2006, p. 58).

The Basemah highland is geographically located in the Bukit Barisan area with an altitude of 600 to 700 MASL with the highest peak of Mount Dempo at 3,159 MASL (Santun et al., 2010, p. 115). It is one of the highlands on the island of Sumatra, Indonesia as a place for the development of the Basemah tribe, which is the oldest community (Santun et al., 2010, p. 117) and one of the dominant tribes in the highlands of southern Sumatra (Bart, 2004, p. 101).

The House is a representation of the diversity of dwellers and geographical conditions (Hasan et al., 2021, p. 22). Ghumah Baghi is a product of the long-isolated Basemah culture (Bart, 2004, p. 129) aged from 100 to 250 years old and already inhabited by 4 to 7 descendants (Bart, 2008, p. 436). Ghumah Baghi is an identity of the Basemah Tribe (Refisrul, 2012, p. 194), Basemah traditional settlements and owners (Arios, 2012, p. 49) (Bart, 2008, p. 435) (Rinaldi & Purwantiasning, 2015, p. 9).

Ghumah Baghi is a place for personal, social, and customary activities of the Basemah tribe with space utilization based on the social level, kinship level, sacred level, social status, and gender (Purnama, 2008, p. 238). The Ghumah Baghi room consists of ghahang, luan, tempuan, beruge, tupik, pagu and paguantu (Table 1). Beruge is a room that can be part of the house or separate from the house.

**Table 1.** The names, positions, and uses of the Ghumah Baghi space

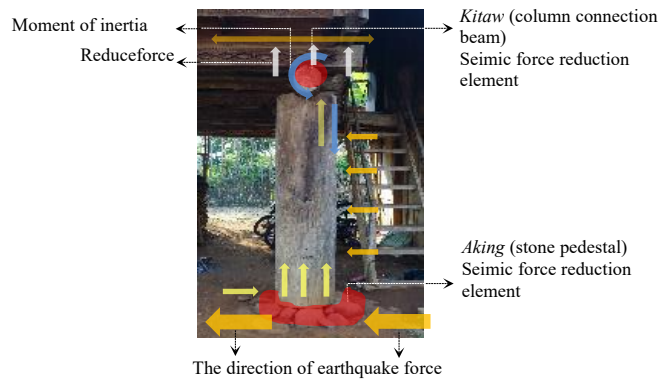
No	Room name (position)	Utilization of space	
		Daily	Ceremony
1	Ghahang (middle)	Circulation, cooking, washing dishes, storage of kitchen utensils, and boys sleeping	Worker seat
2	Luan (middle)	Parents sleeping	The traditional leader's seat
3	Tempuan (middle)	Cooking, eating, and sleeping girl and female guest	Middle-class seats and women's seat
4	Beruge (middle)	Cooking, eating, and sleeping male guest	Worker seat
5	Tupik (middle)	Storage of daily equipment	
6	Pagu (top)	Light storage	
7	Paguantu (top)	Heritage Storage	

Ghumah Baghi is a stilt house, the floor plan is in the form of a square which is larger than the dimensions of the bottom. The floor plan measures 6 x 6 m to 8 x 8 m without a dividing wall but is determined by the difference in floor height. The

uniqueness of material and construction elements is the dominant visual character with ornamentation on the structural element as a highlight of the face (Figure 1).



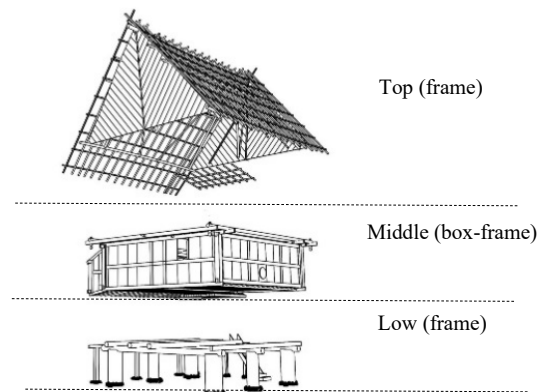
**Figure 1.** Key features of Ghumah Baghi



**Figure 2.** Principle of earthquake adaptation at the bottom of Ghumah Baghi

It has a gable roof with a curved ridge and is called a saddle-shaped roof. Ghumah Baghi structure is a structure separating the bottom, middle, and top (Figure 3) with a box-frame structure of 6 to 9 pillars with a height of between

1.5 to 1.8 meters resting on a rock in the river (Bart, 2004, p. 102). It uses the knock-down construction system and has high adaptability to earthquakes (Figure 2)(Arios, 2012, p. 112) (Rinaldi & Purwantiasning, 2015, p. 9).



**Figure 3.** The divisions and types of Ghumah Baghi structure

The problem of this study was what were the typology of wood joint geometry and its implications for the character of the structure and construction.? This study was aimed at identifying the typology of wood joint geometry in the Ghumah Baghi construction.

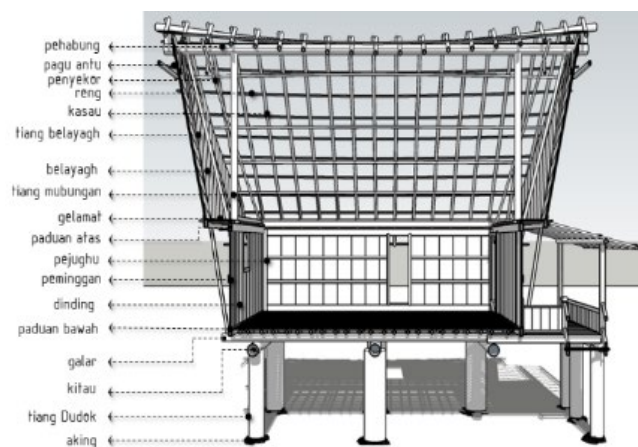
## 2. LITERATURE REVIEW

The social and economic character of the occupants is reflected in the carvings on the door, post, beam, and wall of Ghumah Baghi (Wijaksono et al., 2020, pp. 653–654), which could be divided into Ghumah Tatahan, Ghumah Gilapan and Ghumah Padu Ampagh (Alimansyur et al., 1985, pp. 75–84; Arios, 2012, p. 51). Ghumah Tatahan is a wooden house having carvings on construction elements owned by nobles and traditional leaders and people with high economic level. Ghumah Gilapan is a wooden house with no carvings owned by the community of ordinary people with middle economic level and Ghumah Padu Ampagh is a

house with a combination of wood and bamboo materials for low-income people.

The construction of Ghumah Baghi does not recognize longitudinal joints due to the belief of the Basemah community that the wood used for the construction of the house is solid wood, and if there is a longitudinal joint, it will hurt the lives of the residents of the house. The local name of the construct element *semenn* can be seen in Figure 4. The research object was Ghumah Tatahan because of the dominance of wood material with carvings on construction elements and having a more complex construction than Ghumah Padu Ampagh.

Structure and architecture are two components that make up the form of a building. The relationship between the two can be in the form of structural provisions that affect architectural form, structure as a design with the selection of structural elements based on form, structures that are not considered aesthetic elements, structural provisions that affect form and structure as main components in the form (Azizi & Torabi, 2015, p. 132).



**Figure 4.** Ghumah Baghi construction elements

An important factor in construction building is related to the performance of joints which unify the building elements into a single unit by transferring the forces acting on the joints (Jasieńko et al., 2014, p. 58). This also applies to traditional wooden structures where safety is highly dependent on the performance of joints between the wood elements (Feio et al., 2014, p. 213).

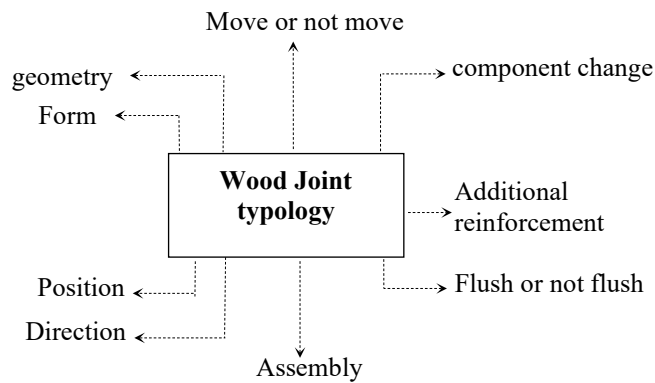
The design of wooden structures in the past was dominated by the skills of carpenters based on tradition and empirical knowledge (Feio et al., 2014, p. 213), and for centuries traditional wood joints have been produced by carpenters with production methods tied to tradition so that each culture has a

specific type of traditional wood joints (Siem, 2017, p. 45). The typology of wood joints can be divided into several categories (Figure 5), as for the wood joint categories are:

1. Arrangement and geometry consist of mortise and tenon joints, notched joints, halved and lap joints, and scarf joints (Branco & Descamps, 2015, pp. 36–38).
2. Form consists of splice joints (Gerner, 1992, p. 35) and connecting joints (Sumiyoshi & Matsui, 1989, p. vi) consisting of corner joints, T-joints, and cross joints.

3. Assembly consists of detachable joints and permanent joints (Zwerger, 2011, p. 85).
4. Move or not move joints consist of movable joints and fixed joints (Zwerger, 2011, p. 85).
5. Position consists of a horizontal joint and a vertical joint (Gerner, 1992, p. 35).
6. Direction consists of straight joints and oblique joints (Gerner, 1992, p. 35).
7. Flush or not flush joints consist of flush joints and not flush joints (Gerner, 1992, p. 35).
8. Additional reinforcement consists of reinforcement joints and without reinforcement joints (Ibnu et al., 2019, p. 36).
9. Component change consists of changing the component joints without changing the component joints (Ibnu et al., 2019, p. 36).

The type of wood joints based on arrangement and geometry is mortise and tenon joints having two components: the mortise hole and the tenon tongue which is at the end of the component inserted into a square hole that is the same size as the hole which is rectangular and has a shoulder as a seat for the component. When the joint is fully entered into the mortise traditional joint, there is a pinhole that hollows out the tenon tongue and the pin makes the joint even stronger. This joint usually connects components with an L or T configuration.



**Figure 5.** Category of Wood Joint Typology

Source: Branco & Descamps (2015, pp. 36); Gerner (1992, p. 35); Sumiyoshi & Matsui (1989, p. vi); Zwerger (2011, p. 85); Ibnu et al. (2019, p. 36)

Half-lap joints are jointed with two elements resting on them. The types of lap joint are full-lap joints with two stacked components; another type is joints that are notched so that they become one thickness, and some joints have pins as reinforcement. These joints are divided into a basic shape with the edges bisected at right angles and an angle (Branco & Descamps, 2015, pp. 36). Butt joints are only with reinforcement such as glue and nails, so a butt joint is the weakest part of the structure (Patel et al., 2009, p. 273). A scarf joint is a joint of two components with an end-to-end joint (Branco & Descamps, 2015, p. 36). Notched joints are a special variation of the halved joints in that the two components are not split too deep (Zwerger, 2011, p. 88). The notch can be in the form of a V-shaped groove which is generally perpendicular to the long beam element (Branco & Descamps, 2015, p. 36). The forked or neck joint is a T-joint with a branched pedestal as support (Zwerger, 2011, p. 89)

This joint due to the weight of the material is a safe joint without having to use reinforcement (Gerner, 1992, p. 13). The wide joint is a joint that is considered unimportant in wood construction. This joint is in the form of a joint between boards developed in the form of tongues, bets or ledges in bar construction (Gerner, 1992, p. 16). A tie joint is a wooden joint using rope media. As joint reinforcement in traditional construction, the rope material used is rattan or palm fiber.

### 3. MATERIALS AND METHODS

#### 3.1. Case Study

The research location was 8 villages in the development area of the Basemah tribe in the highlands around Mount Dempo in Pagaralam City and Lahat Regency, South Sumatra Province, Indonesia (Table 2). The selection of the villages

was based on the location of the villages around Mount Dempo as the center of the Basemah culture and the development area of the Basemah tribe

towards Semendo, one of the development directions of the Basemah tribe (Figure 6)

**Table 2.** Research areas

Code	Village	MASL (m)	South	East
GB01	Geramat	586	4°02'19.5"	103°30'28.7"
GB02	Pajar Bulan	579	4°02'09.8"	103°32'41.4"
GB03	Bangke	936	4°06'56.1"	103°32'00.9"
GB04	Pagar Wangi	815	4°02'33.0"	103°13'07.0"
GB05	Tebat Benawa	989	4°07'03.0"	103°18'09.0"
GB06	Tebat Lereh	939	4°06'47.0"	103°19'28.0"
GB07	Meringang	930	4°06'48.0"	103°19'39.0"
GB08	Plang Kenidai	814	4°04'27.0"	103°18'16.0"



**Figure 6.** Codes and locations of case study

### 3.2. Analytical Methods

This study used a qualitative method because it was non-experimental research with data collection and analysis focusing on understanding and emphasizing meaning - finding, uncovering, and understanding a phenomenon in a certain context using qualitative comparative analysis techniques to obtain cause and effect case study (Edmonds & Kennedy, 2017, p. 141). This study used an interpretive naturalistic approach by studying natural conditions to understand and interpret a phenomenon through collections and empirical studies (Denzin & Lincoln, 1998, p. 3). The category of qualitative research in this study was case study research that is descriptive or explanatory to describe entities in the form of a single or group to

cause and effect in the discovery of basic principles (Astalin, 2013, p. 122).

This study was a qualitative case study because it was a non-experimental study with natural data collection from the field in 8 cases of Ghumah Baghi with a comparative analysis of the typology of wood joints from library sources to find and reveal the similarities and the variations of the typology of wood joints in Ghumah Baghi with the wood joints in the library and to find the causes of using the types of wood joints. This was a preliminary study to find the tectonic aspects of Ghumah Baghi's architecture as one of the aspects in making a prototype of the earthquake-responsive and knock-down house based on the structure and construction of Ghumah Baghi.

The stages of the architectural typology study are data collection, identification of data according

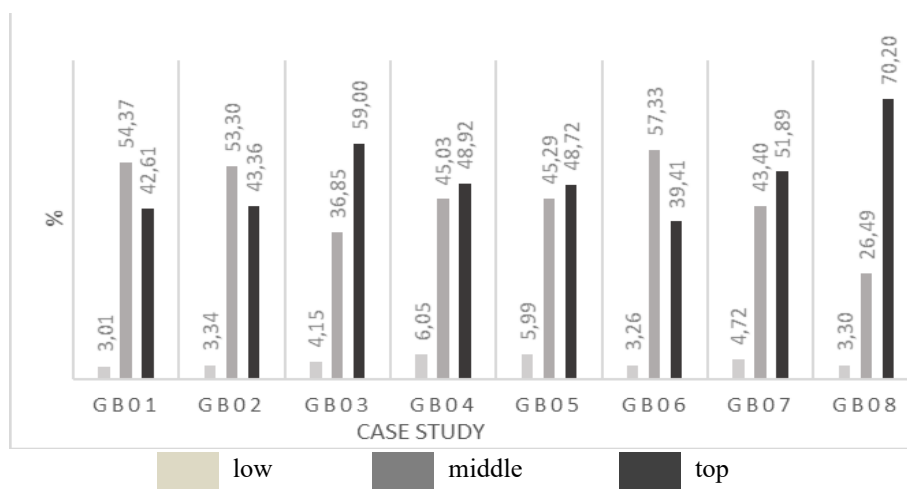
to the characteristics, determination of categories, and preparation and organization of data according to their classification. (Pangarsa et al., 2012, p. 80). The stages in this study were collecting the data from documents and archives in the form of writings on the construction of Ghumah Baghi and the typology of wood joints from secondary sources, interviews with traditional leaders (*jurai tuwe*) and homeowners about various wood materials, joint systems, and construction assembly, direct observation to understand the design of wood joints and the measurement of physical artifacts to get the dimensions of wood joints. The results of the measurement would be followed by a 3-dimensional depiction to get a digitally measured image. Data processing was in the form of making categories and coding the identification results from secondary sources. The data were analyzed by comparing the joint typology from the literature study with the results of joint identification in the field. The conclusions were drawn from the synthesis of the results of the comparison to find a match between the results of the comparison and variations in the types of joints.

#### 4. RESULTS AND DISCUSSION

The discussion of the results of this study includes the number and types of joints at the bottom, middle, and top as well as the variations of each type of joints. The number of joints from the case study ranged from 1,590 (GB 07 Meringang) up to 2,846 (GB08 Pelang Kenidai) joints (Table 3). The distribution of joints based on their location showed that the bottom had the lowest percentage of the number of joints ranging from 3.26%. (GB06 Tebat Lereh) up to 6.05 % (GB04 Pagar Wangi). The number of joints in the middle and upper parts varied with the dominance of the middle having the highest number of joints in the case of GB01 Geramat, GB02 Pajar Bulan, and GB06 Tebat Benawa ranging from 53.30% to 57.33% and the number of joints at the top was dominant in the case of GB03 Bangke, GB04 Pagar Wangi, GB05 Tebat Benawa, GB07 Tebat Lereh, and GB08 Pelang Kenidai ranging from 48.72% to 70.20% (Figure 7).

**Table 3.** Number of joints based on location

Case study	Joints location						Σ total
	Low		Middle		Top		
	Σ	%	Σ	%	Σ	%	
GB01	72	3,01	1.299	54,37	1.018	42,61	2.389
GB02	81	3,34	1.293	53,30	1.052	43,36	2.426
GB03	81	4,15	719	36,85	1.151	59,00	1.951
GB04	123	6,05	916	45,03	995	48,92	2.034
GB05	110	5,99	832	45,29	895	48,72	1.837
GB06	71	3,26	1.248	57,33	858	39,41	2.177
GB07	75	4,72	690	43,40	825	51,89	1.590
GB08	94	3,30	754	26,49	1.998	70,20	2.846



**Figure 7.** Percentages of the number of joints by location

The average percentage of the number of joints based on their location had a ratio of 1:11.55:13.1 (bottom: middle: top). This ratio showed that the bottom was the simplest construction because this section had the lowest number of construction elements, and the top section was the most complicated part because it had the largest number of construction elements. The number of joints was dependent on the dimensions of Ghumah Baghi, the shape and dimensions of the material, and the selection of the type of structural system. The joints in the Ghumah Baghi construction based on geometry and arrangement were categorized into 8 types, namely mortise and tenon joints, halved and lap joints, butt joints, scarf joints, forked joints, wide joint, s and tie joints.

The lower structure of Ghumah Baghi included the construction of piles under and stairs with 5 types of joints dominated by halved and lap joints by 48.73% (Figure 8). The middle structure included floor and wall construction with 7 joint types dominated by halved and lap joints by 49.03%. The upper structure included roof truss construction, gavel, and pagu antu with 6 types of joints dominated by halved and lap joints by 82.65%.

Overall halved and lap joints covered 66.19% of the joint types in the Ghumah Baghi construction. This fact indicated that the Ghumah Baghi construction was easy to disassemble due to the simplicity of the joint techniques and the use of simple equipment. Halved and lap joints are simple joints due to easy workmanship.

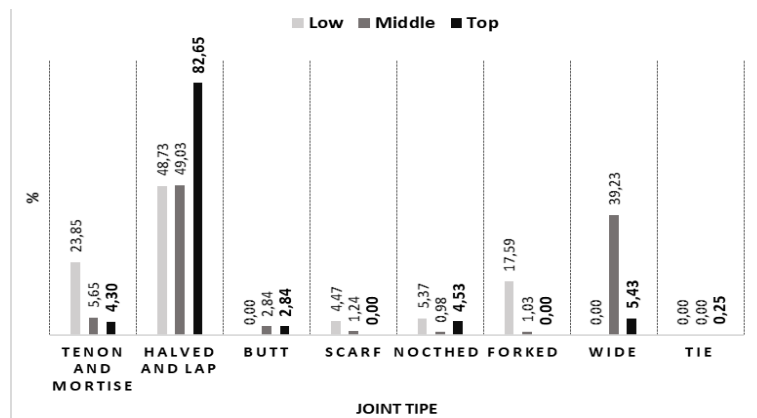


Figure 8. Percentages of joints types by location

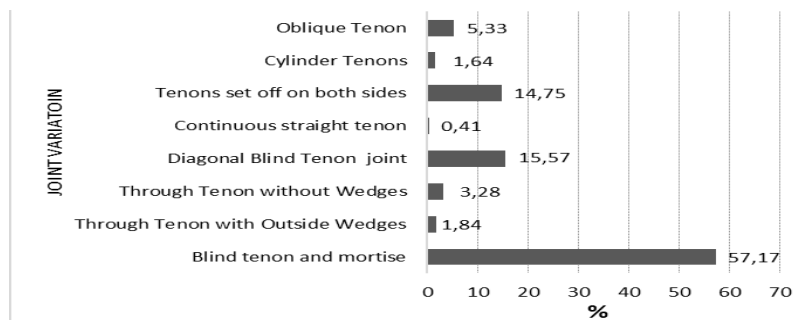
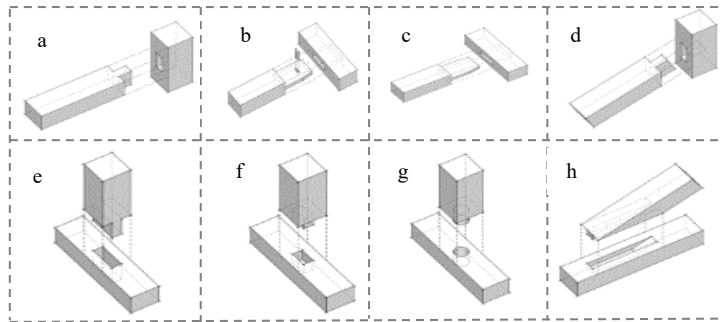


Figure 9. Percentages of variations of mortise and tenon joint

In a full-lap joint, the wood is joined without processing, and the wood is stacked without or with the addition of reinforcement (peg, rope, and nail). In the wood processing of a half-lap joint, cut 2 sides of wood using the saw and remove the part of the sawn wood using the chisel. The procedure to make this joint is the simplest compared to other types of joints. Mortise-and-tenon joints in the Ghumah Baghi construction covered 5.67% of the total

number of joints with some variations based on the shape (block and cylinder) and tenon length (blind, through & outside), joint reinforcement (with and without peg), and tenon direction (perpendicular and oblique), making up 8 variations (Figure 10). Blind mortise-and-tenon was the dominant mortise and-tenon variation covering 57.17% found in wall trusses and roof trusses (Figure 9).



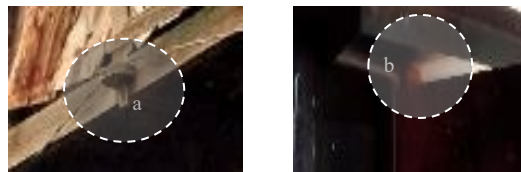


(a) Blind mortise and tenon (b) Through tenon with outside wedges (c) Through tenon without wedges (d) Diagonal blind Tenon (e) Diagonal blind tenon (f) Continuous straight tenon (g) Cylinder tenon (h) Oblique tenon

**Figure 10.** Variations of mortise-and-tenon joints

The typical mortise-and-tenon joint variation in the Ghumah Baghi construction was the through tenon with outside wedges joint (Figure 11a) located at the joint of the roof stud beam and the horizontal ceiling truss beam (ceiling); the post had a function as an element holding the joint loose due to

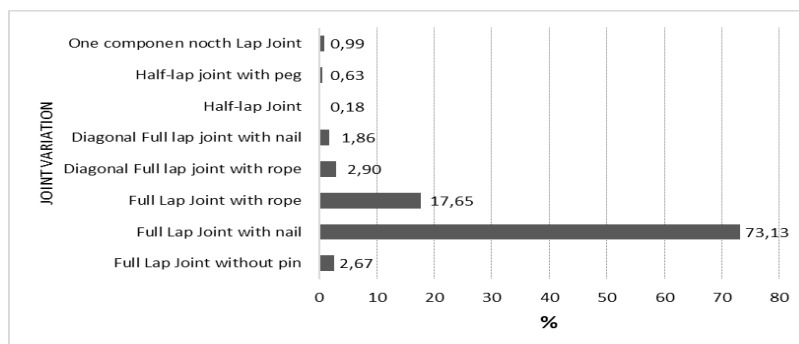
deflection girders due to the vertical stresses of the roof studs. A cylinder tenon joint (Figure 11b) is a cylindrical protrusion from the door (formed from a single wooden plank) that functions as a hinge to serve as an element to open and close the door.



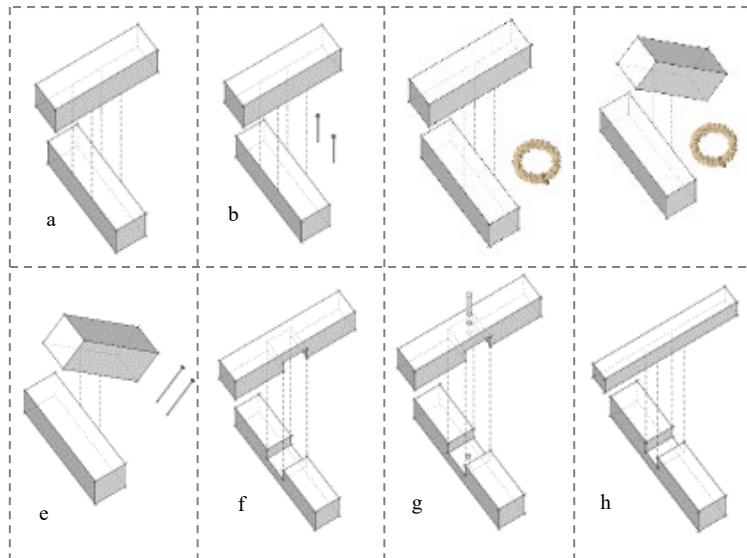
**Figure 11.** (a) through tenon with outside wedges joint (b) cylinder tenon joint

Halved and lap joints in the Ghumah Baghi construction covered 66.19% of the number of joints and had some variations based on the presence of joint reinforcement (without reinforcement, pegs, ropes, and nails), the depth of the notch (full-lap and half-lap) and the direction of component placement (perpendicular and oblique), forming into 8 variations (Figure 13). Full-lap joint with the nail was the dominant joint by 73.13% (Figure 12) found

in the construction of the floor and roof truss as a result of technological development using nails as joint reinforcement which replaces ties that were previously used to strengthen the full-lap joint. This would change the character of the construction that is easy to disassemble into a permanent construction due to changes in the joint reinforcement components.

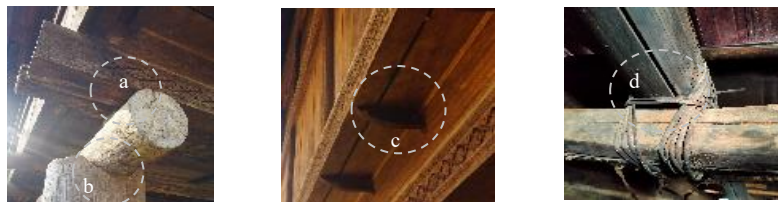


**Figure 12.** Percentages of variations of halved and lap joints



(a) Full lap joint without pin (b) Full lap joint with nail (c) Full lap joint with rope (d) Diagonal Full lap joint with rope (e) Diagonal full lap joint with nail (f) Half lap joint (g) One component notch lap joint (h) Half lap joint with peg

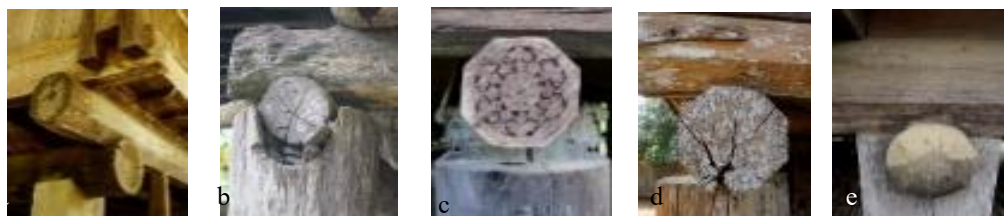
**Figure 13.** Variations of halved and lap joints



**Figure 14.** (a) full lap joint without pin (b) half-lap joint (c) one component notch lap joint (d) full lap joint with rope

The typical halved and lap joint variation in the Ghumah Baghi construction was the full lap joint without a pin. The typical halved and lap joint variation in Ghumah Baghi constructions was the full lap joint without pin (Figure 14a) found in the supporting beams under the column (kitaw) and the middle support beam (galar) and half lap joints (Figure 14b). Between the underside of the pile (ari) and the column of the underside of the beam (kitaw)

was a joint with simple workmanship because it required little processing of components and the assembly process was by stacking the elements. This joint was also a joint type that could withstand horizontal forces from earthquakes. One component notch lap joint (Figure 14c) was the joint found on the front floor frame of Ghumah Baghi at the cover beam.

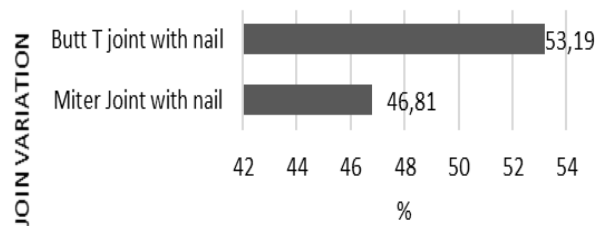


(a) Lamban Ulu Ogan at Peninjauan Ogan Komerling Ulu South Sumatera (b) Lamban Tuha Surabaya South Ogan Komerling Ulu South Sumatera (c) Lamban cara Ulu at Minangga East Ogan Komerling Ulu South Sumatera (d) Umah Tuha at Way Kanan Lampung (e) Lamban Pesagi at Kenali West Lampung

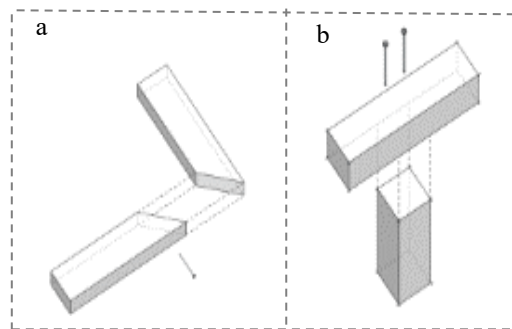
**Figure 15.** Halved and lap joints in the vernacular houses in the highlands of southern Sumatra, Indonesia

This joint was on the face of the Ghumah Baghi and there was a floor elevation so the use of this joint had an aesthetic value to close the gap due to the elevation of the floor. Full-lap joint with rope (Figure 14d) was found on the floor truss beams and roof truss. The use of rattan skin rope was a reinforcement of the joint used in the past before the influence of using metal (nail) material as reinforcement for the joint. Halved and lap joint was used in vernacular houses in the highlands of southern Sumatra, Indonesia.

The butt joint in the Ghumah Baghi construction covered 2.73% of the total joints and consists of 2 variations namely the butt T joint with nail the and miter joint with nail (Figure 16) found on the window frame. The window element with panel is a construction element resulting from the influence of the times because the former Ghumah Baghi window was a removable part of the wall. The butt T joint with nail was a wooden joint located at the top, namely the joint between the rafter's stiffener frame and the fascia, with nails as a substitute for wooden dowels as a reinforcement element for the joint (Figure 17).



**Figure 16.** Percentages of variations of butt joints

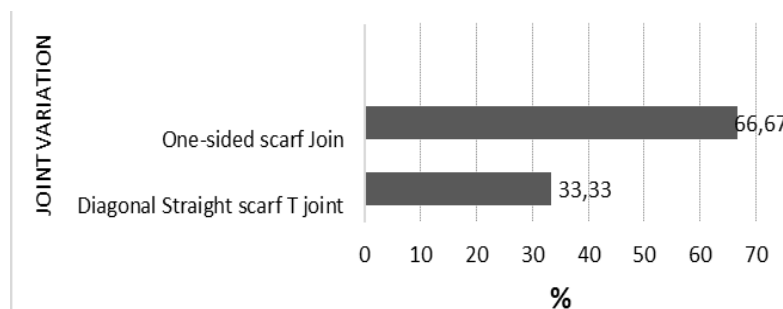


(a) Miter joint with nail (b) Butt T joint with nail

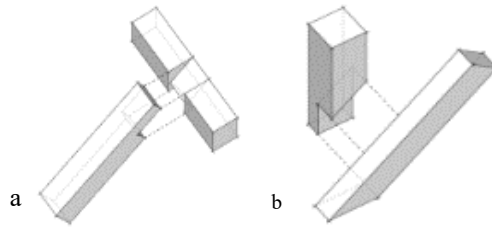
**Figure 17.** Variations of butt joint

Scarf joints in Ghumah Baghi construction covered 0.73% of the total number of joints with 2 variations (Figure 18): one side scarf joint being (Figure 19a) the dominant joint covering 66.67% found in the joint between the banister and the

ladder, and the use of nail reinforcement. The diagonal straight scarf joint (Figure 19b) was a joint between the ladder and the floor beam functioning as the main support for the upper stairs.



**Figure 18.** Percentages of variations of the scarf joints

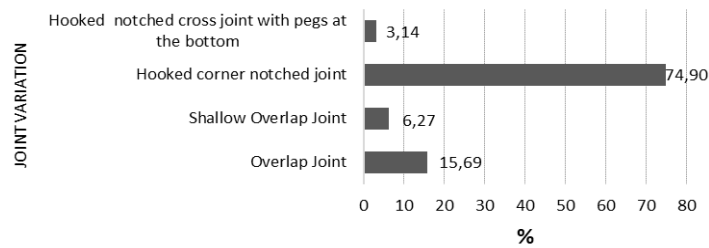


(a) One side scarf joint (b) Diagonal straight scarf T joint

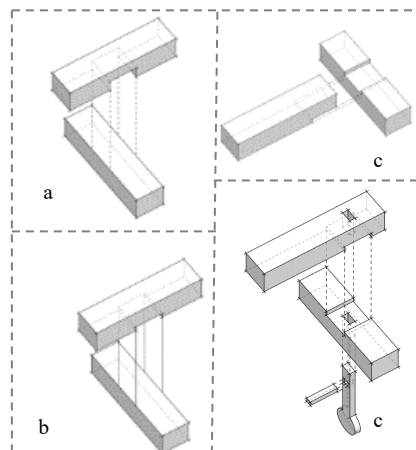
**Figure 19.** Variations of scarf joint

Notched joints in the Ghumah Baghi construction covered 2.96% of the number of joints, consisting of 4 variations of joints based on flush or not flush, into notches (shallow or half), and joint reinforcement (with or without peg) (Figure 20). The

hooked corner notched joint (Figure 21c) was the dominant joint covering 74.9%, located in the base frame for the placement of the upper structure, and also functioned as a ceiling frame (gelamat).



**Figure 20.** Percentages of variations of notched joints

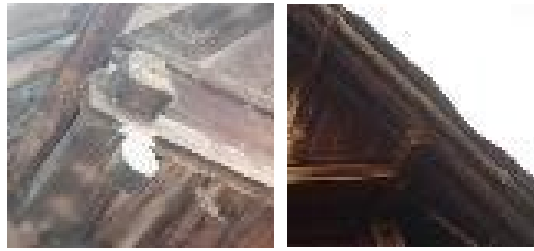


(a) Overlap joint (b) Shallow overlap joint (c) hooked corner notched joint (d) Hooked notched corner joint with peg at the bottom

**Figure 21.** Variations of notched joints

A typical variation of notched joints in the Ghumah Baghi construction was the joint to the upper support frame functioning as a ceiling frame where the hooked notched corner joint with a peg at the bottom joint (Figure 22a) was used when the

gable support beam was under the roof support beam, and the hooked corner notched joint was used when the gable supports were above the roof supports.

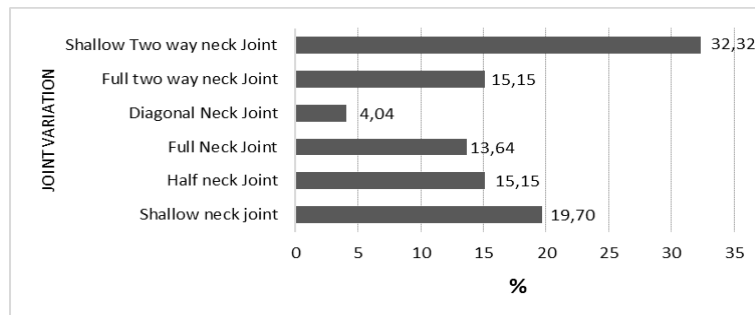


**Figure 22.** (a) Hooked notched corner joint with a peg at the bottom (b) Hooked corner notched joint

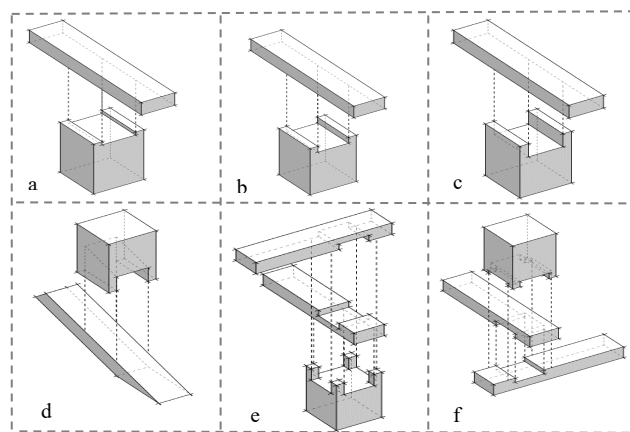
Forked joints in the Ghumah Baghi construction covered 1.15% of the total number of joints with 6 variations of the joints based on the number of joint elements (one or two-way), the depth of the notch (shallow, half, and full), and the direction of the components (perpendicular and oblique) (Figure 23). The shallow two-way neck joint (Figure 24f) was the most dominant variation covering 32.32% of

the total forked joints. This joint is in the form of 3 dimensions by connecting 3 elements, namely two main beams wall (alloy) with corner posts of wall truss (penjughu) in the center of Ghumah Baghi.

The shallow neck joint is the core joint in the construction of the Lankepatamuan houses in Kalimantan, Indonesia (Figure 25). It is known as the Salaman joint (Wuysang et al., 2017, p. 32)

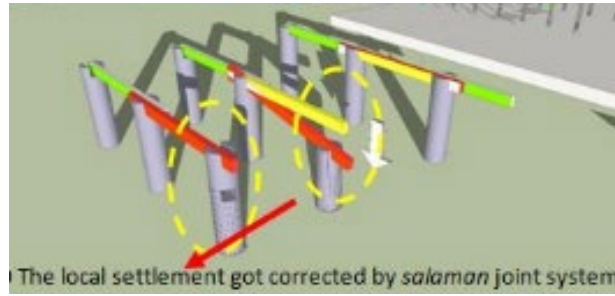


**Figure 23.** Percentages of variations of forked joints



(a) Shallow Neck joint (b) Half neck joint (c) Full neck joint (d) Diagonal neck joint (e) Full two-way neck joint (f) Shallow two-way neck joint

**Figure 24.** Variations of forked joints



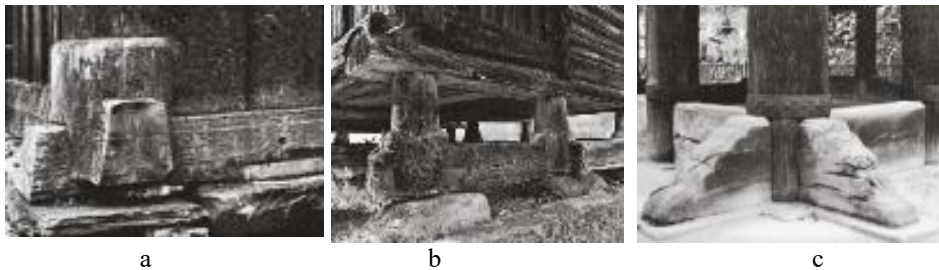
**Figure 25.** Salaman, the core joint of Lankepatamuan in Kalimantan, Indonesia  
 Source: (Wuysang et al., 2017, p. 30)

The typical forked joint in the Ghumah Baghi construction was the full two-way neck joint (Figure 26) at the bottom between the lower tie beams and the underside of the pile (tiang dudok) which binds

the underside of the pile with two beams from two directions to maintain the stability of the bottom construction. This joint has similarities with the joints in Japan and Norway (Figure 27).



**Figure 26.** (a) Full two-way neck joint (b) Shallow two-way neck joint

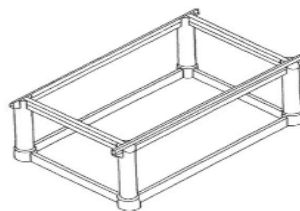


**Figure 27.** Full two-way neck joint (a) church in Bygdoy Norway (b) house in Gudbrandsdalen Norway (c) bell tower in Kyoto Japan

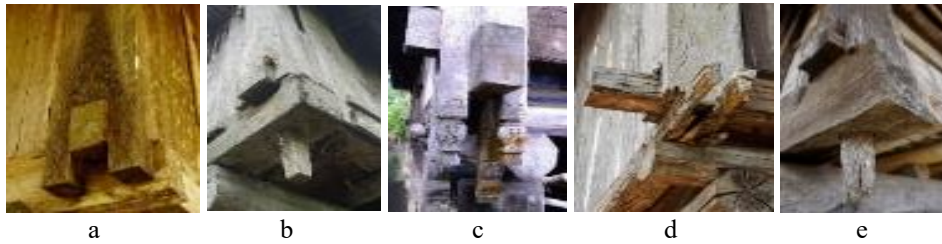
Source: (Zwerger, 2011, pp. 136 -138)

The shallow two-way neck joint (Figure 26b) in the middle located at 4 corners of the middle is one of the components that make up the box frame structure system which consists of a series of columns and beams that are rigid on all sides of the

box (Figure 28). This box frame system was a structural system in the middle of Ghumah Baghi. The two-way neck joint with some variations was used in vernacular houses in the highlands of southern Sumatra, Indonesia (Figure 29).



**Figure 28.** Principle of box-frame construction  
 Source: (Zwerger, 2011, p. 160)



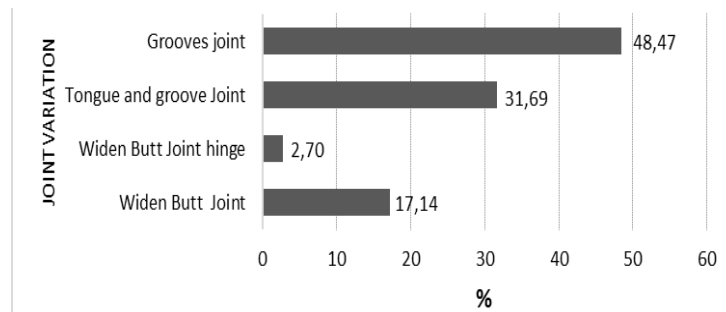
(a) Lamban ulu Ogan at Peninjauan Ogan Komerling Ulu south Sumatra (b) Lamban Tuha Surabaya South Ogan Komerling Ulu South Sumatra (c) Lamban cara Ulu at minangga East Ogan Komerling ulu south Sumatra (d) Umah Tuha at Way Kanan Lampung (e) (f) Lamban Pesagi at Kenali West Lampung

**Figure 29.** Variations of two-way neck joints in the vernacular houses in the highlands of southern Sumatra Indonesia

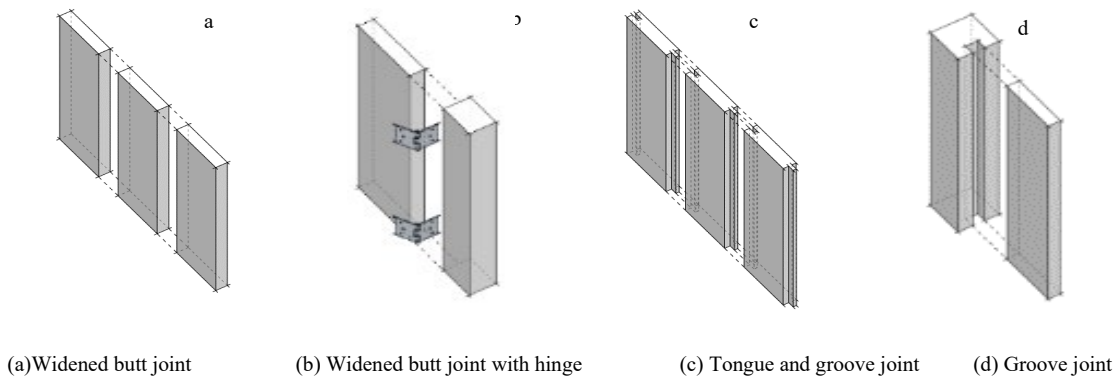
Wide joints in the Ghumah Baghi construction covered 20.44% of the total number of joints, located on the floor, wall, and gable construction with 4 variations of the joints based on geometry (changed or not changed) and the presence of reinforcement (with or without hinge) (Figure 30). The groove joint (Figure 31d) was the dominant joint; this joint was in the construction of the wall, the joint between the wall and the wall frame (alloy, sake, railing, and corner). The joint variation between the floor covering, wall, and gable consists of a widened butt joint (Figure. 31a), the joint without changing the geometry of the element which still allows gaps in the joint due to shrinkage of the

wood, and the tongue and groove joint (Figure 31c) which changes the geometry by making grooves and tongues to prevent joint gaps when wood shrinks. Widened joint with a hinge is the joint that exists in window construction, the joint between the shutters and the window frame.

The tie joint in the Ghumah Baghi construction was one of the typical joints found on the roof of the joint between the lower truss beams and the rafters locking the beams with rattan skin ropes. The lower rafter beam (Figure 32a) and the joint with dowels as binding media were attached to the lower rafter beam (Figure 32b).

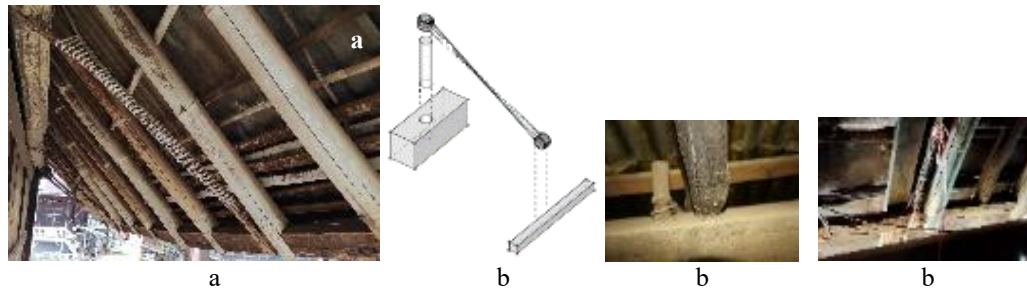


**Figure 30.** Percentages of variations of wide joints



(a)Widened butt joint (b) Widened butt joint with hinge (c) Tongue and groove joint (d) Groove joint

**Figure 31.** Variations of wide joints



**Figure 32.** (a) Tie joint (b) Tie joint with peg

The results of the identification of the types of wood joints in the construction of eight Ghumah Baghi's in eight villages located in Pagaralam City

and Lahat Regency, South Sumatra, Indonesia showed that there were 8 types of joints with 36 variations (Table 4)

**Table 4.** Types and variations of wood joints in Ghumah Baghi

No	Joints	Variations of Joints
1	Mortise- and-tenon joints	(1) Blind mortise and tenon (2) Through tenon with outside wedges (3) Through tenon without wedges (4) Diagonal blind tenon (5) Diagonal blind tenon (6) Continuous straight tenon (7) Cylinder tenon (8) Oblique tenon
2	Halved and lap joints	(9) Full-lap joint without pin (10) Full-lap joint with nail (11) Full-lap joint with rope (12) Diagonal full-lap joint with rope (13) Diagonal full-lap joint with nail (14) Half-lap joint (15) One component notch lap joint (16) Half-lap joint with peg
3	Butt joints	(17) Miter joint with nail (18) Butt T-joint with nail
4	Scarf joints	(19) One side scarf joint (20) Diagonal straight scarf T-joint
5	Notched joints	(21) Overlap joint (22) Shallow overlap joint (23) Hooked corner notched joint (24) Hooked notched corner joint with a peg at the bottom
6	Forked joints	(25) Shallow Neck joint (26) Half neck joint (27) Full neck joint (28) Diagonal neck joint (29) Full two-way neck joint (30) Shallow two-way neck joint
7	Wide joints	(31) Widened butt joint (32) Widened butt joint with hinge (33) Tongue and groove joint (34) Groove joint
8	Tie joints	(35) Tie joint (36) Tie joint with peg

## 5. CONCLUSIONS

Ghumah Baghi was the result of a construction formation consisting of a series of components, and the joints became the smallest element of the construction playing an important role in the success of the construction. This study is important because wood joint research is the first step of the study on the Ghumah Baghi structure and construction to find out the strength of joints and construction, component assembly, and architectural tectonic and earthquake resistance. The results of this study could be part of making a prototype of an earthquake-resistant disassembled building based on the Ghumah Baghi structural system.

The Ghumah Baghi construction had 8 joint types with 36 joint variations with some wood joints

like halved and lap joints and the two-way neck joint also used in the construction of vernacular houses in the highlands of South Sumatra Indonesia. The use of metal materials as joint reinforcement is the effect of technological development where metal media (nail and hinge) replace the previous reinforcement elements (wood peg and rattan skin rope). Joints using nails were the dominant joint in the construction of Ghumah Baghi.

The type of wood joints in Ghumah Baghi was dominated by roll joints having high adaptation to the forces caused by earthquakes and the joints easy to disassemble, so further research is needed to identify the resistance of joints to earthquakes and the joint assembly method and to identify the knock-down system in the Ghumah Baghi construction.



## REFERENCES

- Alimansyur, M., Abdullah, M., Djumiran, Makmur, Z., & Sidin, T. (1985). *Arsitektur tradisional daerah Sumatera Selatan* (J. Siregar & R. Abu, Eds.). Departemen Pendidikan dan Kebudayaan.
- Arios, L. R. (2012). *Arsitektur Rumah Baghi di Kota Pagaram*. In N. Effendi (Ed.), *Bunga rampai budaya Sumatera Selatan budaya Basemah di Kota Pagaram, 1*, 1–117. BPSNT Padang Press. [http://repositori.kemdikbud.go.id/10882/1/bunga\\_rampai\\_budaya\\_sumatera\\_selatan.pdf](http://repositori.kemdikbud.go.id/10882/1/bunga_rampai_budaya_sumatera_selatan.pdf)
- Astalin, K. P. (2013). Qualitative research design: A conceptual framework. *International Journal of Social Science & Interdisciplinary Research*, 2(1), 118–124.
- Azizi, M., & Torabi, Z. (2015). The role of structure in creating architectural space. *Current World Environment*, 10(Special-Issue1), 131–137. <https://doi.org/10.12944/cwe.10.special-issue1.18>
- Bart, B. (2004). Architecture on the move processes of migration and mobility in the south Sumatran Highland. In S. Reimar & J M Nas Peter (Eds.), *Indonesian House Traditional Transformation in Vernacular Architecture, 1*, 99–132. KITLV Press.
- Bart, B. (2008). The house that was built overnight guidelines on the construction and use of Southern Sumatran Rumah Uluan. In R. Schefolg, P. J. M. Nas, G. Domenig, & R. Wessing (Eds.), *Indonesian House Volume 2: Survey of Vernacular Architecture in Western Indonesia* (p. 716). KITLV Press.
- Branco, J. M., & Descamps, T. (2015). Analysis and strengthening of carpentry joints. *Construction and Building Materials*, 97(1), 34–47. <https://doi.org/10.1016/j.conbuildmat.2015.05.089>
- Chang, W. S., Hsu, M. F., & Komatsu, K. (2006). Rotational performance of traditional Nuki joints with gap I: Theory and verification. *Journal of Wood Science*, 52(1), 58–62. <https://doi.org/10.1007/s10086-005-0734-7>
- Denzin, N., & Lincoln, Y. (1998). *Strategies for qualitative inquiry* (First edition). Sage Publication Inc.
- Edmonds, W. A., & Kennedy, T. D. (2017). *An applied guide to research designs quantitative, qualitative and mix methods* (Second). Sage Publication Inc. <http://lccn.loc.gov/2015045991>
- Feio, A. O., Lourenço, P. B., & Machado, J. S. (2014). Testing and modeling of a traditional timber mortise and tenon joint. *Materials and Structures/Materiaux et Constructions*, 47(1–2), 213–225. <https://doi.org/10.1617/s11527-013-0056-y>
- Gerner, M. (1992). *Handwerkliche Holzverbindungen der Zimmerer*. Deutsche Verlags-Anstalt.
- Hasan, M. I., Prabowo, B. N., Haja, H., Mohidin, B., & Bava, H. H. (2021). An architectural review of privacy value in traditional Indonesian housings: Framework of locality-based on islamic architecture design. *Journal of Design and Built Environment*, 21(1), 21–28. <https://doi.org/10.22452/jdbe.vol21no1.3>
- Ibnu, I.M, Siswanto, A., Prihatmaji, Y. P., & Nugroho, S. (2019). Teknologi konstruksi bongkar pasang pada hunian masa lampau studi kasus Ghumah Baghi. *Seminar Nasional Avoer XI*, 32–38.
- Jasieńko, J., Nowak, T., & Karolak, A. (2014). Historyczne z łą cza ciesielskie. (Historical carpentry joints). *Journal of Heritage Conservation*, 40(February), 58–82.
- Kassim, S. J., Majid, N. A., Shariff, H. M., & Qariah, T. A. (2019). The hybrid aesthetics of the Malay vernacular: Reinventing classifications through the classicality of South East Asia’s palatial forms. *International Journal of Recent Technology and Engineering*, 8(1), 340–350.
- Lodson, J., Emmanuel Ogbaba, J., & Kenechi Elinwa, U. (2018). A lesson from vernacular architecture in Nigeria. *Journal of Contemporary Urban Affairs*, 2(1), 84–95. <https://doi.org/10.25034/ijcua.2018.3664>
- Martynenko, A. (2017). Vernacular values in architectural heritage. The case of Vale de Poldros. *Architecture and Urban Planning*, 13(1), 15–23. <https://doi.org/10.1515/aup-2017-0002>
- Oliver, P. (1997). Typologies. In P. Oliver (Ed.), *Encyclopedia of vernacular architecture of the World: theory and principles*, 1, 609–610. Cambridge University Press.
- Pangarsa, G. W., Titisari, E. Y., Ridjal, A. M., & Ernawati, D. J. (2012). Tipologi nusantara green architecture dalam rangka konservasi dan pengembangan arsitektur nusantara bagi perbaikan kualitas lingkungan binaan. *Ruas*, 10(2), 78–94.
- Patel, V., Masood, S. H., & Waterman, T. (2009). Investigation of butt joint failure mode in sofa frame. *Assembly Automation*, 29(4), 371–377. <https://doi.org/10.1108/01445150910987790>

- Poletti, E., Vasconcelos, G., Branco, J. M., & Koukouviki, A. M. (2016). Performance evaluation of traditional timber joints under cyclic loading and their influence on the seismic response of timber frame structures. *Construction and Building Materials*, 127, 321–334.  
<https://doi.org/10.1016/j.conbuildmat.2016.09.122>
- Purnama, D. H. (2008). *Studi makna struktural rumah uluan orang Besemah di daerah dataran tinggi bukit barisan provinsi Sumatera Selatan* [Desertasi]. Universitas Padjadjaran Bandung.
- Puspitasari, P., & Lakawa, A. R. (2020). Revealing the vernacular concept through proportions in architecture. *International Journal of Scientific and Technology Research*, 9(3), 1415–1420.
- Refisrul. (2012). Sumbai : Sistem pemerintahan tradisional masyarakat Besemah di Sumatera Selatan. In E. Nusyirwan (Ed.), *Bunga Rampai Budaya Sumatera Selatan Budaya Basemah di Kota Pagaram* (pertama, 190–226). BPSNT Padang Press.  
[http://repositori.kemdikbud.go.id/10882/1/bunga\\_rampai\\_budaya\\_sumatera\\_selatan.pdf](http://repositori.kemdikbud.go.id/10882/1/bunga_rampai_budaya_sumatera_selatan.pdf)
- Rinaldi, Z., & Purwantiasning, A. W. (2015). Analisa konstruksi tahan gempa rumah tradisional suku Besemah di Kota Pagaram Sumatera Selatan. *Prosiding Seminar Nasional Sains Dan Teknologi 2015, November*, 1–10.
- Santun, D. I. M., Murni, & Supriyanto. (2010). *Iliran dan uluan dinamika dan dikotomi sejarah kulturan Palembang*. Eja Publisher.
- Siem, J. (2017). The single-step joint—a traditional carpentry joint with new possibilities. *International Wood Products Journal*, 8, 45–49.  
<https://doi.org/10.1080/20426445.2017.1302148>
- Sumiyoshi, T., & Matsui, G. (1989). *Wood joints in classical Japanese Architecture* (J. Nagy, Ed.; First Edit). Kajima Institute Publishing Co.Ltd.
- Wijaksono, P., Martono, & Suprianto, A. P. (2020). Cultural study: Ghumah Baghi philosophy of Besemah ethnic society. *Proceedings of International Joint Conference on Art and Humanities (IJCAH 2020)*, 491, 653–657.  
<https://doi.org/10.2991/assehr.k.201201.112>
- Wuysang, P. A., Prijotomo, J., & Dwisusanto, Y. B. (2017). Tectonic method for traditional longhouse the core form of So Langkepatamuan Architecture. *The International Journal of Engineering and Science (IJES)*, 6(1), 24–32.
- Zwenger, K. (2011). *Wood and wood joints building traditional of Europe, Japan, and China* (Second Edi). Birkauer GmbH.