

The 5th International Conference of Euro Asia Civil Engineering Forum (EACEF-5)

Traffic performance analysis of u-turn and fly over u-turn scenario; a case study at Soekarno Hatta Road, Palembang, Indonesia

Rhaptalyani H. Della^{a,*}, Hanafiah^a, Joni Arliansyah^a, Riga Artiansyah^a

^a*Sriwijaya University, Jl. Palembang-Prabumulih, KM. 32, Palembang 30662, Indonesia*

Abstract

On section of road often more than one U-turn median opening that operates, but sometimes this make long queue in some periods time. It's causing many factors like on-coming speed and maneuver that make waiting time. Basically, no procedure or guideline for U-turn sections design. The attempted to find the optimal approach regarding acceptances gap that occurs at U-turn median opening and the appropriate application criteria for the road that use U-turn median opening based on the capacity and traffic demand existing in the U-turn median opening. Gap acceptances influential for operational of U-turn, where the vehicle while performing maneuvers will decrease the speed of vehicles. The evaluation of the delay and travel time will provide to know the performance of the U-turn median opening. The purpose of this study is to evaluation the performance of U-turn median opening with study case at Soekarno Hatta Road, Palembang, Indonesia. The specific objectives in this study are to find the operational performance of U-turn movement by delay and travel time analysis by HCM 2000 and to evaluate the performance of U-turn using Vissim Simulation program. Vissim Simulation used for simulated 2 difference of width median opening and U-turn fly over. Simulated case study using Vissim simulation with different of width median opening showed in narrow width median opening will make major delay and the high of travel time. Based on the comparison of four scenarios of U-turn models and existing model. The best performance of U-turn facilities showed on 4th model. The 4th model is U-turn with fly over design, showed the performance are saturation degree 0.7333, delay study 3,43905, delay vissim 3,133479, and the travel time is 526,20. The travel time would lower with an increasingly the width of median opening. Simulation showed that travel time and delay slight differences when the width of median opening large than existing U-turn. Then comparison from U-turn with road median opening design and fly over U-turn design showed the last design give the best in traffic performance.

© 2015 The Authors. Published by Elsevier Ltd. This is an open access article under the CC BY-NC-ND license (<http://creativecommons.org/licenses/by-nc-nd/4.0/>).

Peer-review under responsibility of organizing committee of The 5th International Conference of Euro Asia Civil Engineering Forum (EACEF-5)

Keywords: U-turn; median opening; design; delay; traffic performance.

* Corresponding author. *E-mail address:* rhaptalyani@unsri.ac.id

1. Introduction

The planning of U-turn need geometric and traffic planning aspect. In Indonesia, not much regulation system talk about U-turn facilities, it quite same in Highway Capacity Manual from Transportation Research Board, actually no regulation and manual for knowing U-turn characteristics. According to the problems mentioned above, the problem to find the best performance in U-turn facilities to known the characteristics became a necessary to do. Find the best U-turn facilities that are safety and fill of operational aspects of U-turn movements.

2. Literature Review

Literally, U-turn is turning round facilities for maneuvers of vehicle performing which is implanted by U shaped driving that aims to travel to the opposite lane (Rohani, 2010). In Indonesia, median opening which can be used as a U-turn, the regulations about road and highway facilities in Indonesia issued by Public Works Departement, U-turn facilities regulations issues only find in:

- Regulation of Median Opening Planning (*Tata Cara Perencanaan Pemisah*), No. 014/T/BNTK/1990
- Specification of Road Median Opening (*Spesifikasi Bukaah Pemisah Jalur*), SKSNIS-04-1990-F
- U-turn Planning Module (*Pedoman Perencanaan Putaran Balik (U-turn)*), No.06/BM/2005

The procedures of designing a U-turn from Regulation of Median Opening Planning can see on Fig. 1 above.

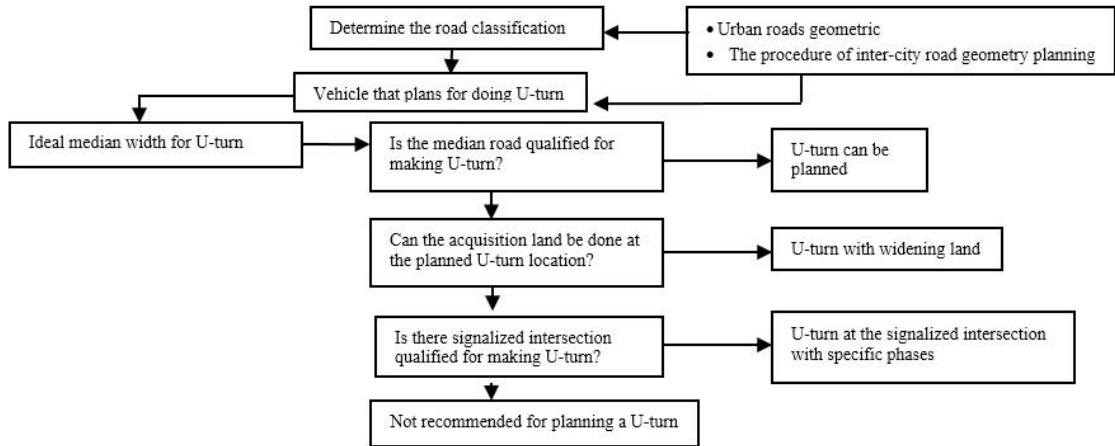

Fig. 1. The procedure of median opening planning.

3. Methodology

3.1. Research Procedure

The research will be conducted based on the methodological chart depicted in Fig. 2. The flow chart is a general description of research procedures.

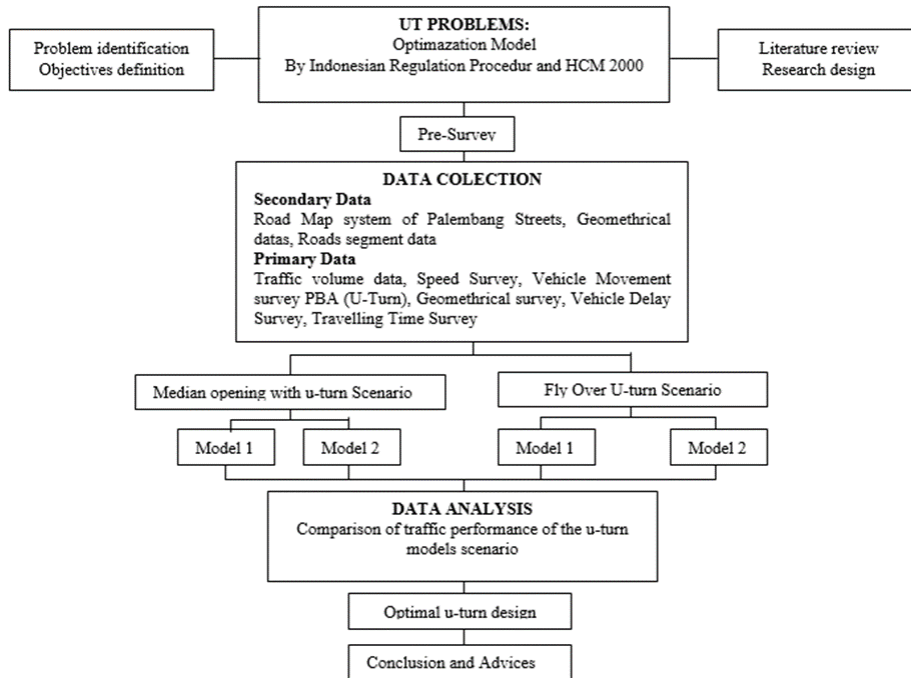

Fig. 2. General descriptions of research procedures.

3.2. Collecting Data

The data collecting in the segment of Soekarno Hatta road, Palembang. That road is one of national road in South Sumatera Province, Indonesia, which Palembang as the capital city. Geometric data showed the existing U-turn using canalization U-turn type, Fig. 3.

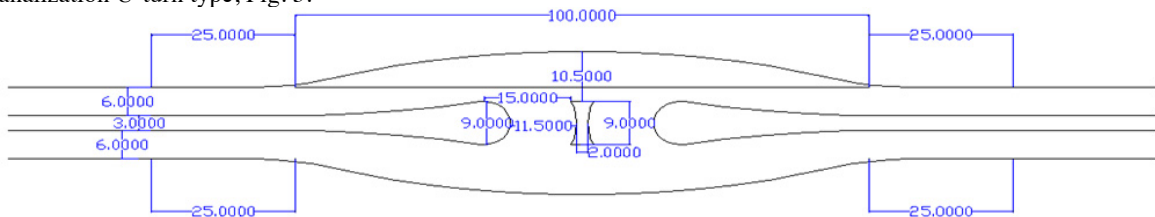

Fig. 3. Geometric data of Soekarno Hatta U-turn.

By the traffic data collection in a week, showed the average of traffic 22179 vehicles/day with motorcycles as the most dominan vehicles. Fig. 4 representing the result of traffic data collection.

4. Discussion

4.1. Traffic Performance of Existing U-turn

Analysis data of the traffic performance for U-turn analyzation using some parameter, from data collecting in the U-turn segment in Soekarno Hatta road, Palembang, showed those parameter:

- Capacity**
 By Indonesian Highway Capacity Manual, capacity value in existing U-turn is 1746.29 vehicles/hour.
- Degree of Saturation**
 Degree of Saturation in level of service (LoS) C with value 0.79, the result based on traffic volume $Q = 1379.406$ vehicles/hour and capacity $C = 1746.29$ vehicles/hour.
- Traffic Delay**
 Based on degree of saturation 0.79, showed the delay in the number of 3.7045 second/vehicle.
- Queue length**
 Queue length by the delay time about 6.309 second/vehicle.

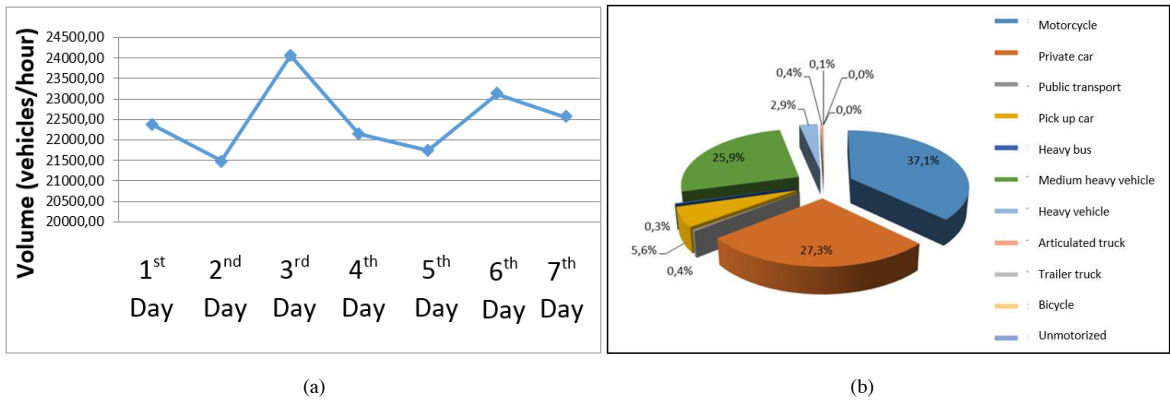

Fig. 4. Traffic Data Colection (a) Vehicles volume data; (b) Vehicles data.

4.2. Scenarios of U-turn Model Design

For knowing the best performing of the traffic of U-turn, the scenarios needed to showed it. This research consisted by 2 scenarios of U-turn design, which first scenario given 2 design model of U-turn with road median opening and second scenario design 2 models with fly over U-turn. Geometric design of U-turn models scenario 1 showed in Fig. 5 and scenario 2 in Fig. 6.

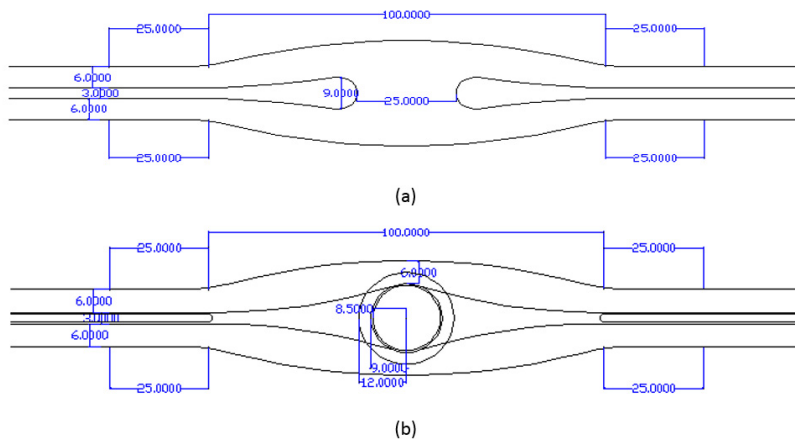

Fig 5. U-turn model scenario 1, median opening U-turn : (a) Model 1; (b) Model 2.

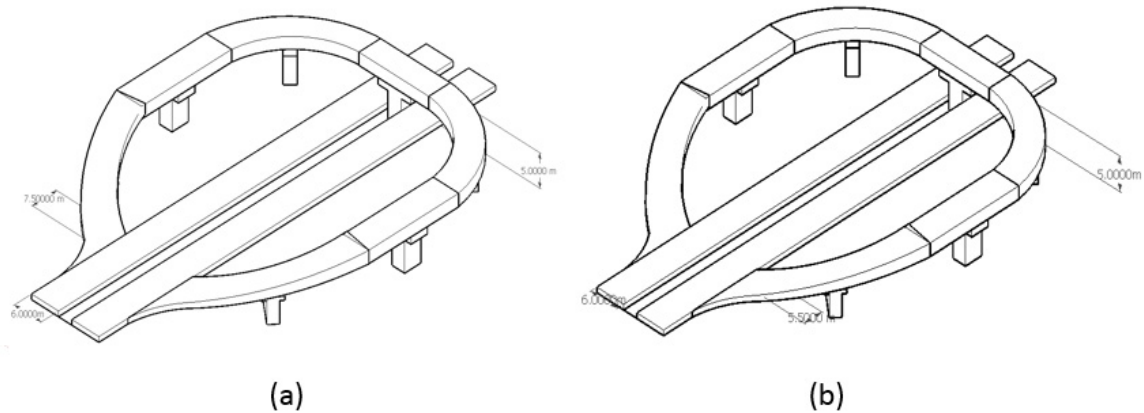

Fig 6. U-turn model scenario 2, fly over U-turn : (a) Model 1; (b) Model 2.

4.3. Traffic Performance of U-turn Model Scenario 1

In this scenario, two models design by renewing geometric data from existing U-turn. The result of traffic performance needed to make the comparison of the new models. Some parameters using as the comparison to know the best performance of the models. From existing data and new geometric design, some parameters shown this result:

- (1) U-turn Scenario 1 Model 1
 - a. *Capacity*, from the data of existing U-turn, knowing the capacity of this new design is 1746.29 vehicles/hour.
 - b. *Degree of saturation*, level of service (LoS) in level C with value 0.79.
 - c. *Delay*, based of degree of saturation 0.79, by Indonesian Highway Capacity Manual analysis showed 3.7045 second/vehicle. The result more less same with Vissim Software analysis that showed 3.6054 second/vehicle.
 - d. *Queue length*, about 2.8745 second/vehicle.
- (2) U-turn Scenario 1 Model 2
 - a. *Capacity*, from the data of existing U-turn, knowing the capacity of this new design is 1780.87 vehicles/hour.
 - b. *Degree of saturation*, level of service (LoS) in level C with value 0.77.
 - c. *Delay*, based of degree of saturation 0.77, showed 3.6326 second/vehicle by Indonesian Highway Capacity Manual analysis and 3.2355 second/vehicle.
 - d. *Queue length*, about 2.8745 second/vehicle.

4.4. Traffic Performance of U-turn Model Scenario 2

In this scenario, two models design with fly over model for renewing geometric data. The traffic performance showed by some parameter, that are:

- (1) U-turn Scenario 2 Model 1
 - a. *Capacity*, from the data and analysis using Indonesian Highway Capacity Manual, knowing the capacity of this new design is 1711.71 vehicles/hour.
 - b. *Degree of saturation*, level of service (LoS) in level C with value 0.81.
 - c. *Delay*, based of degree of saturation 0.81, by Indonesian Highway Capacity Manual analysis showed 3.7793 second/vehicle. Vissim Software analysis showed delay number above 3.9132 second/vehicle.
 - d. *Queue length*, about 2.8548 second/vehicle.

(2) U-turn Scenario 2 Model 2

- a. *Capacity*, by data and analysis with Indonesian Highway Capacity Manual, capacity of this model above 1881.00 vehicles/hour.
- b. *Degree of saturation*, level of service (LoS) in level C with value 0.73.
- c. *Delay*, based of degree of saturation 0.73, showed 3.4391 second/vehicle by Indonesian Highway Capacity Manual analysis and 3.1335 second/vehicle.
- d. *Queue length*, about 2,8216 second/vehicle.

By the calculation of traffic performance existing U-turn and new design models, showed the model 2 in scenario 2 given the best performance, which the comparison given on the tabel 1. Form the comparison showed delay and travel time in model 2 scenario 2 given the best value of degree of saturation depend on existing and other design model.

Table 1. Comparison of Traffic Performance Scenario U-turn Models

Model	Degree of Saturation	Delay by IHCM	Delay by Vissim	Travel Time by Vissim
Existing	0.7899	3.7045	3.993067	813.20
1.	0.7899	3.7045	3.605393	763.20
2.	0.77457	3.63259	3.235545	584.40
3.	0.80586	3.77934	3.913205	599.60
4.	0.7333	3.43905	3.133479	526.20

5. Conclusion

Based on data analysis, traffic performance calculation on existing U-turns and scenarios models design, then the conclusion of this research are:

- Analysis result showed delay of median opening U-turn have the number of delay more than fly over U-turn.
- Traffic performance existing U-turn and new design models analysis, showed the model 2 in scenario 2 given the best performance with the delay number less than other design.
- U-turn on Jalan Soekarno Hatta Palembang needed to have new design to get the best traffic performance.

References

- [1] Directorate of Highway. 1990. Panduan Survey dan Perhitungan Waktu Perjalanan Lalu Lintas. Jakarta: Departement of Public Works.
- [2] Directorate of Highway, 1992. Regulation of Intersection Urban City Highway No. 01/T/BNKT/1992, Jakarta Indonesia.
- [3] Directorate of Highway. 1997. Indonesian Highway Capacity Manual (IHCM), Jakarta, Indonesia.
- [4] Directorate of Highway. 2005. U-turn Planning Module No: 06 / BM / 2005, Jakarta, Indonesia
- [5] Kasan, Muhammad, etc. 2005. Traffic Characteristic of U-turn in Palu City Road. Palu, Smartek.
- [6] Indonesian Standarization Committe, 2004. Geometric Highway. RSNI T - 14 – 2004, Jakarta Indonesia.
- [7] Rules of Ministry of Transportation No. KM 14 tahun 2006 About Road Management and Traffic Engineering
- [8] Rahman, Arief and Nooryadi, Irwan. 2007. Planning of Fly Over for Highway and Railway in Tirus Tegal. Undergraduate Thesis, Diponegoro University.
- [9] Rhaptalyani, 2012. Evaluation of The Performance of U -Turn Movement Using Vissim Simulation Program; A Case Study At Burlian Road, Palembang, Indonesia, Procceding of 15th FSTPT symposium Transportation Forum, Bekasi, Indonesia.