



The International Symposium on Agricultural and Biosystem Engineering

Proceedings

Supported by:



Sponsored by:





**The International Symposium on
Agricultural and Biosystem Engineering
2013**

Improving The Role of Agricultural and Biosystem Engineering
Toward Food & Energi Self-Sufficiency and Sustainable Agriculture

AUGUST 28-29 2013
YOGYAKARTA, INDONESIA

PROCEEDINGS

Organized by:



Departement of Agricultural Engineering
Faculty of Agricultural Technology
Universitas Gadjah Mada



Perhimpunan Teknik Pertanian
PERTETA
Cabang Yogyakarta

Supported by:



Korean Society for Agricultural Machinery
대한농업기계학회



Message from The Chairperson Of Isabe 2013

It is my honor to welcome you to the International Symposium on Agricultural and Biosystem Engineering 2013. Thank you all for gather here today at the Faculty of Agricultural Technology for attending this important meeting. The ISABE 2013 is held in August 28-29 organized by Department of Agricultural Engineering, Faculty of Agricultural Technology, Universitas Gadjah Mada and the Indonesian Society of Agricultural Engineering (PERTETA). The theme of ISABE 2013 is "Improving the role of agricultural and biosystem engineering toward food & energy self-sufficiency and sustainable agriculture". The objectives of the symposium are to disseminate knowledge, to promote research and development, to obtain the latest information, as well as to exchange technical information in agricultural and biosystem engineering innovation. Moreover, the symposium will provide opportunity to strengthen networking among Indonesia and international academia, government and industries. The meeting will feature a series of keynote speech in plenary sessions, presentations in technical sessions, poster sessions, cultural night, as well as excursion.

I am very pleased to welcome all the guest speakers: Prof. Dongil Chang (Chungnam National University, Korea), Dr. Takashi Okayasu (Kyushu University, Japan), Prof. Vinod Jindal (Mahidol University, Thailand), Ir. Patrick van Schijndel (Eindhoven University of Technology, Netherlands), Prof. Kenan Peker (Selcuk University, Turkey), Prof. Fajrettin Korkmaz (Ataturk University, Turkey), as well as Dr. Lilik Sutiarto (Universitas Gadjah Mada, Indonesia). And joining us to deliver a congratulatory speech is Prof. Seung-Je Park (President of Korean Society for Agricultural Machinery, KSAM). Thank you very much for all of you for your contribution in this symposium.

I am also pleased to greet participants of 92 selected papers, among them are 8 papers from Korea, 6 from Japan, 1 from Taiwan, 1 from Austria, 1 from Thailand, and the remaining 75 papers are from Indonesia, as well as 3 posters. For delegates who do not present papers, thank you for your participants. I hope you can enjoy all the agenda.

I would like to express my sincere gratitude to all colleagues, sponsors, organizing committee, steering committee for their support and cooperation for making this event successfully performed.

Finally, thank you again for your participation and welcome to the ISABE 2013 meeting.

Chairperson of ISABE 2013
Dr. Rudiati Evi Masithoh



ISBN : 978-602-14315-0-4

Editor:

**Lilik Sutiarmo
Murtiningrum**

Proceedings

The International Symposium on Agricultural and Biosystem Engineering 2013

Theme:

Improving The Role of Agricultural and Biosystem Engineering
Toward Food & Energi Self-Sufficiency and Sustainable Agriculture

© Published by:

Jurusan Teknik Pertanian, Fakultas Teknologi Pertanian
UNIVERSITAS GADJAH MADA

Copyright Law Protected

Don't to quote, reproduce and translate some or all of these books
without the permission of the publisher

First Edition: 2013

ISBN : 978-602-14315-0-4



[Home](#)

[Cover](#)

[Forewords](#)

[ISBN](#)

MAIN PAPER

Informatization Agriculture in Japan

Author : Takashi Okayasu

[read](#)

Sub-Theme : Post Harvest and Food Engineering

A-1

**Design of Thermal Conductivity Apparatus Base on
Transient-state Radial Cylinder Method**

Authors : Bambang Dwi Argo, Wahyunanto A. Nugroho, Yoes B. Pristya and Ubaidillah

[read](#)

A-2

**Effect Extraction Method of Composition Fatty Acid
Dieng Carica Seeds Oil (*Carica candamarcensis* HOK) as Edible Oil**

Authors : Bambang Dwi Argo, Wahyunanto A. Nugroho, Yoes B. Pristya and Ubaidillah

[read](#)

A-3

**Adsorption Equilibrium Studies of Bio-Based Butanol from
Fermentation Broth by Immobilized of Potato Starch Sorbent**

Authors : Dina Wahyu, Tsair-Wang Chung

[read](#)

A-4

**Quality Review of Three Types of Mangoesteen
Using Ultrasonic Waves**

Authors : Emmy Darmawati, Amir Hamzah

[read](#)

A-5

Influence of Air Flow Rate on Drying Characteristics of Clove

Authors : Junaedi Muhidong, inge Scorpi Tulliza and Ishak

[read](#)

A-6

**Performance Test of Equipment and Machines of
Banana Miller for Mechanization Technology Development of
Banana Processing in South Kalimantan Province**

Authors : Retno Endrasari, Susy Lesmayati

[read](#)

A-7

**Continuous Dehumidification of Organic Sorbent Powder in
Two Connected Fluidized Beds with a Cooling and a Heating Pipe**

Authors : Sukmawaty, Syahrul

[read](#)

A-8

**Method of Waxing on Quality and Shelf-life of Semi-cutting
Mangosteen in Low Temperature Storage**

Authors : Usman Ahmad, Emmy, Darmawati, and Nur Rahma Refilia

[read](#)

A-9

**Acidified Sodium Chlorite Treatments for Improving
Shelf-life of Unripe Shredded Papaya**

Authors : Vinod K. Jindal, Pompailin Sinrat and Nipon Chamchan

[read](#)

A-10

Fighting for Malnutrition in Indonesia by Production of Artificial Rice

Based on Arrow Root and Cassava with Addition of Cowpea

Authors : Danial Fatchurrahman, Wenny Bekti Sunarharum, Anugerah Dany Priyanto, Fathy Fasial Bahanan

[read](#)

A-11

Product Features and Cost Analysis of MOCAS (Modified Cassava Starch) Based Bakery Products

Authors : Darmawan Ari Nugroho, Ibnu Wahid FA

[read](#)

A-12

Fuel Feeding Rate Controlling Base on The Temperature Distribution Simulation on Rosella Pod (*Hibiscus sabdariffa linn*) Drying Process

Authors : Dyah Wulandani, Leopold Oscar Nelwan, I Made Dewa Subrata

[read](#)

A-13

Identification of Determinant Factors in Processing and Technology: A Case Study of Fruit Processing Industries (FPIs) in Indonesia

Authors : Ida Bagus Suryaningrat

[read](#)

A-14

Profile of The Peanut Moisture Content During Deep Bed Drying

Authors : Ansar, Sirajuddin, Widhiantari

[read](#)

A-15

Effect Lindak Cacao Fruit Maturity (*Theobroma Cacao F.*) With High Level of Polyphenols as Antioxidants

Authors : Jumriah Langkong and Mulyati M. Thahir

[read](#)

A-16

Study of Active Packaging System by Using Ethylene Adsorber to Prolong The Storage Life of Avocado Fruits (*Persea americana Mill*)

Authors : Lilik Pujantoro, andi Nurfaidah and Yadi Haryadi

[read](#)

A-17

The Development of Technology Bundle in Packaging of Export Quality of Mangosteens' Transportation

Authors : Ni Luh Yulianti and Gede Arda

[read](#)

A-18

Synthesis of Chitosan-Ag+ as Antibacterial Material

Authors : Shinta Rosalia Dewi, Sri Juari Santosa and Dwi Siswanta

[read](#)

A-19

Development of Coffee Beans Caffeine Extraction Using Pressure and Temperature Controllable Reactor

Authors : Sukrisno Widiotomo

[read](#)

A-20

Optimization of The High Refined Cellulose Process Production from The Sago Fiber Waste by a Delignification Process Involving Nitric Acid,

Sodium Hydroxide and Hydrogen Peroxide as The Delignificating Agent

Authors : Supranto

[read](#)

Sub-Theme : Energy and Agricultural Machinery

B-1

Technical Analysis and Performance Test of A Small Scale Banana Milling Machine

Authors : Ade M Kramadibrata, Totok Herwanto and Boy Ricardo

[read](#)

B-2

Design of Measurement System Water Content in Pressurized Chamber Without Disturbing The Process

Authors : Anang Lastriyantanto, Sudjito S , Roedy S and Sumardi

[read](#)

B-3

Design of Farm Road Construction at The Tertiary Plot of Paddy Field

Authors : Asep Sapei, Erizal, and Tatang Sumarna

[read](#)

B-4

Aerodynamics Properties of Castor Bean and It's Application for

Blower System at Ricinus Castor Bean Hulling Machine

Authors : Cahyawan Catur Edi Margana, Rahmat Sabani, and Baharuddin

[read](#)

B-5

The Effect of Sugarcane Litter Compost to Soil Physical Mechanical

Properties and Ratoon Sugarcane Performance

Authors : Iqbal, Tineke Mandang, E. Namaken Sembiring, M.A. Chozin

[read](#)

B-6

Tillage Characteristics of Rotavators in Famland Condition of Korea

Authors : Dae-Cheol Kim , Ju-Seok Nam, Myoung-Ho Kim and Dae-Chun Kim

[read](#)

B-7

Feasibility Analysis of Palm Oil Mill

Effluent Utilization as a Source of Electrical Energy

Authors : Suprihatin, E. Gumbira-Sa'id, O. Suparno, D.O. Suryanto and Sarono

[read](#)

B-8

Potential Production of Agricultural Byproducts and The Economic

Feasibility of Rice Straw as a Feedstock for Bioethanol in Korea

Authors : Yeonghwan Bae, Kidong Park, Keum Joo Park

[read](#)

B-9

Study on Oil Palm Fresh Fruit Bunch Bruise in Harvesting and Transportation as a Function to Quality

Authors : andreas Wahyu Krisdiarto and Lilik Sutiarto

[read](#)

B-10

Application of KUBOTA DC-60 for Paddy Wet Field Harvesting

Authors : Ledyta Hindiani and Gatot Pramuhadi

[read](#)

B-11

Engineering Characteristics and Potential Energy of Oil Palm Fruit Bunches Harvesting

Authors : Wawan Hermawan, Desrial, Muhammad Iqbal Nazamuddin

[read](#)

B-12

Design of Iron Wheel of a Light Tractor for Crop Maintenance in Unconsolidated Paddy Field

Authors : Radite P.A.S, I. W. Astika, D. M. Subrata and A. Azis

[read](#)

B-13

Design and Performance Test of Metal Kiln Venturi Drum Type for Coconut Shell Carbonization

Authors : S. Endah Agustina and Nurul Hasanah

[read](#)

B-14

Design of Sugarcane (*Saccharum officinarum* L) Cutting Machine for Seedling Preparation with Bud-chip Method

Authors : Siswoyo Soekarno, Luqman Budi Setiawan and Askin

[read](#)

B-15

The Clay Content Effect on The formation of Shallow Mole Drainage: An Experimental Study

Authors : Siti Suharyatun, Bambang Purwantana, Abdul Rozaq and Muhjidin Mawardi

[read](#)

B-16

The Usage of Shaft to Shaft Transmission for Rotary Saw Crusher for Paddy Straw

Authors : Tri Tunggal, Tamaria Panggabean and Hilda Agustina

[read](#)

B-17

Functional Interaction Between Pressure and Soil Sinkage for Terrestrial Robotic Vehicles

Authors : Lenny Saulia

[read](#)

B-18

Design a Mechanical Device for Making Briquettes

Authors : Wiludjeng Trisasiwi, Agus Margiwiyatno, Petrus Hary Tjahja Soedibyo

[read](#)

B-19

A Method of Workload Application for Tractor Transmission

Authors : Su Chul Kim, Yoo Joo Kim, Seung Jae Park

[read](#)

Sub-Theme : Land and Water Resources Engineering

C-1

Water Conservation Concern in Surakarta, Indonesia

Authors : Agus Suyanto

[read](#)

C-2

Influence of Increasing Rain due to Climate Change on Forest Slope Stability in Aso City, Kumamoto Prefecture, Japan

Authors : Aril Aditian and Tetsuya Kubota

[read](#)

C-3

Evaluation on Land Use Toward The Environment Support in Ponorogo Regency

Authors : Bambang Rahadi, Tunggul Sutan Haji, Euis Elih Nurlelih and Novia Lusiana

[read](#)

C-4

The Potential and Constraints of Agricultural Engineering Application in Tidal Lowlands Support Sustainable Food Crops Farming

(A Case Study of former Transmigration Area of Banyuasin Regency, South Sumatra Province, Indonesia)

Authors : Husin, Robiyanto H. Susanto, Benyamin Lakitan, Ardiyan Saptawan and M. Yazid

[read](#)

C-5

The Effect of Elevation on Planting Calendar in West Timor

Using Agricultural Rainfall Index (ARI) Method

Authors : Jonathan E. Koehuan and Juli Setyanto

[read](#)

C-6

Analysis of Soil Erosion on The Catchment Area of

Musi Hydro-Power Plant, Bengkulu Province

Authors : Khairul Amri, A. Halim, Ngudiantoro and M. Faiz Barchia

[read](#)

C-7

Distribution and Characteristic of Landslides in Volcanic Mountains of West Java, Indonesia

Authors : Ngadisih, Ryuichi Yatabe, Netra P. Bhandary and Ranjan K. Dahal

[read](#)

C-8

Sediment Related Disasters Induced by Intense Precipitation

During Hurricane Events in Nuevo Leon, Mexico

Authors : Laura Sanchez-Castillo, Tetsuya Kubota, Israel Cantu-Silva and Hasnawir

[read](#)

C-9

Prediction of Water Balance to Determine Growing Period of

Sugarcane (*Saccharum officinarum* L.) in Kalasan, Sleman

Authors : Kamelia Dwi Jayanti, Putu Sudira and Bambang Hendro Sunarminto

[read](#)

C-10

Effect of Silica Extracted from Sugar Cane Bagasse and Compost to

Soil's Physical Properties Under Rainfall Simulator

Authors : Musthofa Lutfi, Hafidz Yuswandhito U and Wahyunanto Agung N

[read](#)

C-11

Determining The Relationships Between Soil Electrical Conductivity and

Some Soil Properties Measured by The Real-Time Soil Sensor (RTSS)

Authors : Ni Nyoman Sulastri, Sakae Shibusawa and Masakazu Kodaira

[read](#)

C-12

Implementing a Minimum Environmental Flow and Its Effects on

Water Management at Sekampung Irrigation Area

Authors : Endro Prasetyo Wahono, D. Legono and Istiarto and B.

[read](#)

C-13

Constraint and Accelerating Factors of Hydrology and Water Resources in

Monsoon Region for The Development of Irrigated Paddy Land:

A Case Study At Bali Island

Authors : Sahid Susanto

[read](#)

C-14

Development of Bio-System Management for Land and Water Conservation of Watershed

Authors : Sahid Susanto

[read](#)

C-15

Prospectives of Water Table Management on Reclaimed Tidal Lowlands With Subsurface Drainage Systems (Case Study of Banyu Urip of Banyuasin, South Sumatera Province. Indonesia)

Authors : Erry Koriyanti, Robiyanto H. Susanto, Dedi Setiabudidaya, Ngudiantoro and F.X. Suryadi

[read](#)

C-16

Load Force of Water in Tubes on Irrigation Water-Scooped Wheel

Authors : Mohammad Agita Tjandra and Apri Roma Habeahan

[read](#)

C-17

Organic Mulching for Soil Water Conservation

Authors : Muhjidin Mawardi

[read](#)

C-18

Performance of Rotary Sprinkler on The Dry Land

Authors : Sitti Nur Faridah, Daniel Useng, Mahmud Achmad, Aryuni

[read](#)

C-19

Soil Conservation Strategy for Potentially Landslide Areas in

Gintung Sub-Watershed, Central Java Province, Indonesia

Authors : Nur Ainun Pulungan, Chandra Setyawan, Sekar Jatiningtyas, Junun Sartohadi

[read](#)

Sub-Theme : Environmental Engineering

D-1

Water Quality (BOD5 and COD) Mapping of West Tarum Canal as Water Resources for Irrigation

Authors : Mouli De Rizka Dewantoro and Yan El Rizal U.D.

[read](#)

D-2

Characteristic of Friction and Shading Rate for Al-Screen Curtain

Authors : Wonsik Choi, Sunmi Choi, Kyungran Kim, Changju Lee, Jaeyoung Byun,

and Sungyoung Park, and Daeyoung

Park

[read](#)

D-3

**Utilization of Cassava Peel as Feed by Fermentation
(Zero Waste Application in Mocaf industry)**

Authors : Andrew Setiawan, Gensi Ginting,
Sukatining Sih, Achmad Subagio

[read](#)

D-4

**Utilization of Tofu Liquid Waste as Growing
Media for
Hair Worm (*Tubifex* sp.) to Reduce
Environmental Pollution**

Authors : Arief Muammar, Aditya Mahendra,
Astia R. Safitri

[read](#)

D-5

**Cultivation of *Chlorella* Sp. in Tofu
Processing Wastewater
Using Raceway Recirculated Pond Bioreactor**

Authors : Wahyunanto A. Nugroho, Mustofa
Lutfi

[read](#)

D-6

**Effect of Transient Organic Load Fluctuation
Using
Cassava Waste Water on Anaerobic Hybrid
Reactor**

Authors : Yusron Sugiarto, Pratin
Kullavanijaya

[read](#)

D-7

**Reduction of Metal Mercury Concentration by
The Plant's *Mata Lele*
(*Azolla pinnata* R. Br.) for Irrigation Water**

Authors : Rusnam, Asmiwanti and Maidar
Pratomo

[read](#)

Sub-Theme : Biophysics Engineering

D-8

**Inoculation of *Uromycladium tepperianum*
Causes Gall Rust Disease in Various
Provenances Sengon (*Falcataria*
moluccana (Miq.)**

Authors : Arief Muammar, Gita Meidiana,
Fitria R. Ratmadanti, Siti H. Nurrohmah and
Diah Rachmawati

[read](#)

D-9

**Spectral Imaging Technology for Quality Evaluation
of Agricultural Materials**

Authors : Byoung-Kwan Cho

[read](#)

D-10

**Phenotypic Characters Analysis of Cross Melon
(*Cucumis melo* L.) Tacapa Cultivar**

Authors : Ganies Riza Aristya ,andika Tripramudya
Onggo, Budi Setiadi Daryono

[read](#)

D-11

Yield Function Model of Vegetable Crops

Authors : Rahman Arif, Rahmad Hari Purnomo
and Hilda Agustina

[read](#)

D-12

**Identification of Nitrogen Status
in *Brassica juncea* L.
Using Color Moment, GLCM and Backpropagation
Neural Network**

Authors : I Putu Gede Budisanjaya, I. K. G.
Darma Putra and I Nyoman Satya Kumara

[read](#)

D-13

**Real Time Detection of Pin Hole on
Worm-eaten Chestnut with 2CCD Camera**

Authors : Soo Hyun Park, Soo Hee Lee,
Seong Min Kim and Sang Ha Noh

[read](#)

D-14

**Growth and Light Utilization
Efficiency of Lettuce as Affected
by Frequency and Duty Ratio of LED
Illumination**

Authors : Jae Su Lee and Yong Hyeon
Kim

[read](#)

D-15

**A Model-Based Approach for Extracting
Viscoelastic
Properties from Ultrasound
Measurements**

Authors : Sri Waluyo, Ya Guo, Gang
Yao and Jinglu Tan

[read](#)

D-16

**Energy and Emissions on Lemuru
(*Sardinella* sp.)Fishing in Bali
Strait**

Authors : Miftahul Choiron, Wahyu
Supartono, Ag. Suryandono

[read](#)

D-17

**Scale-up of Production System Prior
to Commercial
Moss (*Sphagnum* sp) Rooftop Greening**

Material

Authors : Mirwan Ushada, Wildan Fajar
Bachtiar, Ario Wicaksono, Haruhiko
Murase

[read](#)

D-18

**The Role of Seed Producer in
Maintaining Corn Production
Sustainability**

Authors : Winda Amilia, Didik
Purwadi, Henry Yuliando

[read](#)

D-19

**Non Destructive Measurement of Catechin Content in
Gambir**

(*Uncaria gambir Roxb*) Using NIR Spectroscopy

Authors : andasuryani, Y.A. Purwanto, I.W.
Budiastra, K. Syamsu and Lady C.E.Lengkey

[read](#)

D-20

**Non Destructive Prediction of Ripe-Stage Quality of
Mango Fruit**

**CV 'Gedong Gincu' Stored in Low Temperature by NIR
Spectroscopy**

Authors : Yohanes Aris Purwanto, Putri Wulandari
Zainal, Sutrisno, Usman Ahmad,
Yoshio Makino, Seiichi Oshita,
Yoshinori Kawagoe and Shinichi Kuroki

[read](#)

Sub-Theme : System and Management

E-1

**Production Optimization of Crude Palm
Oil at PTPN VII**

**Unit Usaha Betung by Using Goal
Programming Method**

Authors : Rahmad Hari Purnomo, Endo
Argo Kuncoro and Malis Septian

[read](#)

E-2

**Application of Analytical Hierarchy Process
in Selection of Herbal Product**

Authors : Luh Putu Wrasiaty, Dewa Ayu Anom
Yuarini, Ida Ayu Mahatma Tuningrat and
I Made Anom Sutrisna

Wijaya

[read](#)

E-3

**Subak Development Programs to Implement Agro-
Ecotourism**

Authors : Sumiyati, Wayan Windia, I Wayan Tika and
Ni Nyoman Sulastri

[read](#)

E-4

**A Study on Determinant Factor Affecting
Performance of Palm Oil
Productivity in Pelalawan Regency, Riau
Province, Indonesia**

Authors : Widya Alwarritzi and Putu Hangga

[read](#)

E-5

**Design of Wireless Measurement of Soil Gases
and Soil Environment
Based on Programmable-System-On-Chip (PSOC)**

Authors : Arief Sudarmaji, Akio Kitagawa and
Junichi Akita

[read](#)

E-6

**Development of UV and Violet Illumination
System with
High Power LED for Fluorescence Imaging**

Authors : Hoyoung Lee, Moon S. Kim, Soo Hyun
Park and Sang Ha Noh

[read](#)

E-7

**Development of Real Time Change Point
Analysis for
Field Environmental Information in
Agriculture**

Authors : Andri Prima Nugroho, Takashi
Okayasu, Muneshi Mitsuoka,
Eiji inoue, Yasumaru Hirai
and Lilik Sutiarso

[read](#)

E-8

**Simplified Algorithm for Daily Time Step
Simulation of
Standalone PV System Using Peak Sun Hour
Data**

Authors : Dimas Firmanda Al Riza and Syed
Ihtsham-ul Haq Gilani

[read](#)

E-9

**Image Processing Method for Counting of Fish
Eggs and Fish Juveniles**

Authors : I Wayan Astika and Fajar Mulyanti

[read](#)

E-10

**Institutional Culture in Brantas Watershed
Management**

Authors : Nugroho Tri Waskitho

[read](#)

E-11

**Modeling and Simulation of Oil Palm
Plantation Productivity Based on
Land Quality and Climate Using Artificial
Neural Network**

Authors : Hermantoro

[read](#)

E-12

Application of Fuzzy Quantification Theory I in The Criteria Selection of Gate Operation in Blawong Irrigation System, Bantul, Yogyakarta

Authors : Murtiningrum, Mega Primarini and Saiful Rochdyanto

[read](#)

E-13

Kinetic of Drying of Sliced Turmeric with Modified Direct Sun Drying by Employing Greenhouse Effect

Authors : Hanim Z. Amanah, Silvia insan Muliawati and Sri Rahayoe

[read](#)

E-14

Performance Analysis of Horizontal Tube Coffee Roaster Heated by Combustion of Producer Gas of Biomass Gasification

Authors : Bambang Purwantana, Arjanggi Nasution and Bambang Prastowo

[read](#)

E-15

A Quantitative Assessment Model of Water Resource Conservation Measures Case Study At Upper Watershed of Kali Progo

Authors : Chandra Setyawan, Sahid Susanto and Sukirno

[read](#)

E-16

Kinetic of Drying of Banana Chip with Cabinet Dryer

Authors : Joko Nugroho W.K., Ascaryo Dwi Anggoro and Nursigit Bintoro

[read](#)

E-17

The Change of Chili Quality During Storage in Plastic Cup After Hot Water Treatment in Various Temperature and Time

Authors : Devi Yuni Susanti, Sri Rahayoe, Budi Rahardjo and Jesica Elviana

[read](#)

POSTER SESSION

P-1

Making Blondo Flour as Protein Source Food with Physical, Mechanical and Chemical Treatments on Virgin Coconut Oil (Vco) Processing Waste

Authors : Anak Agung Istri
Sri Wiadnyani, and I Wayan
Rai Widarta

[read](#)

P-2

**Development of a Colorimetric
Taste Sensor Based on Dye-
Bead Conjugated Array
and Imaging System for White
Wines**

Authors : Soo Chung, Soo
Hyun Park, Tu San Park,
Seongmin Park, Daesik Son and
Seong In Cho

[read](#)

P-3

**Rotating Force of Vanes on
Irrigation Water-Scooped
Wheel**

Authors : Mohammad Agita
Tjandra and Qaddara Fahada

[read](#)



The International Symposium on Agricultural and Biosystem Engineering 2013

Improving The Role of Agricultural and Biosystem Engineering
Toward Food & Energi Self-Sufficiency and Sustainable Agriculture

AUGUST 28-29 2013
YOGYAKARTA, INDONESIA

PROCEEDINGS

Organized by:



Departement of Agricultural Engineering
Faculty of Agricultural Technology
Universitas Gadjah Mada



Perhimpunan Teknik Pertanian
PERTEETA
Cabang Yogyakarta

Supported by:



Korean Society for Agricultural Machinery
사단법인 한국농업기계학회

Sponsored by:



The International Symposium on Agricultural
and Biosystem Engineering
Yogyakarta, 28-29 August 2013

The usage of shaft to shaft transmission for rotary saw crusher for paddy straw

¹Tri Tunggal, Tamaria Panggabean, and Hilda Agustina

Faculty of Agriculture, Sriwijaya University, Inderalaya

E-mail: tritungga@ymail.com

E-mail: tamaria_p@yahoo.co.id

E-mail: hildagustina@gmail.com

Abstract

The production of organic fertilizer was still constrained by low crushing capacity, especially for paddy straw. This material has not been utilize optimally for organic fertilizer. Paddy rice **harvest index** is about **0,5**, meaning paddy rice plant produced straw as much as 50 percent of the total material which was yielded by paddy plantation. It is a potential source for organic fertilizer. The problem is that farmers could cut it into small piece in high capacity. Several machines have been designed to solve this low capacity but many trouble operations found by these machines. In this

research, the knives were replaced by rotary saws. These rotary saws were connected to the shaft by screw mode.

The objective of this research was to create a capable machine that could crush the paddy straw and overcome the disadvantage of previous machines. Another objective was to get the yield as small as possible so the decomposition process will run rapidly.

This research used an engineering design method. It was conducted through 5 steps; they were Definition of the problem, Gathering of information, Generation of alternative solutions, Evaluation of alternatives and decision making, and Communication of the results. The designed machine was drawn into technical drawing and then fabricated it at the Agricultural Engineering Workshop. The rotary saws were rotated by a 7.5 hp-diesel engine. The material capacity was 190.6 kg per hour at 1400 rpm while the fuel consumption was 0.85 L/hour.

In conclusion, the shaft to shaft transmission could be applied to the **rotary saw crusher** with a lighter fabrication and smaller size.

Keywords: rotary saws, paddy straw crusher, organic fertilizer

INTRODUCTION

Sustainable agriculture is an agricultural practice that apply organic matter as much as possible to grow plant rather than chemical compounds. It has been proven that the usage of chemical fertilizer intensively could decrease soil quality, killed some soil microorganism, and contaminate the environment primarily water source. It can not be disputed that chemical application increase the agricultural production. The fast population growth means the increasing demand of food. Green Revolution was introduced in Europe and USA around 1960s to solve this condition. In this program, the effort to fulfill the food need was conducted by the introduction high production plants and application of agrochemical compounds to increase the plant yield like chemical fertilizer and pesticides. In Indonesia, this concept was adapted at around 1970s and have been practiced widely at all over agricultural areas. The production was increased significantly but the negatif effect also occurred that affected the human health and environment, like soil acidification, soil compaction, nutrients unbalanced, high energy consumption, environment issue, vanishing a certain plant species, the

enhance of insects and weeds retention to chemical compounds, and the ethics aspect related to soil development intensively (Saragih, 2008 and Basedow, 2003).

Organic agricultural practice was introduced as an alternatif solution to eliminate the destruction that was caused by the heavy use of agrochemical. One alternatif that could be applied is to substitute the chemical fertilizer with organic fertilizer. This fertilizer is made of a mixture of plant residus which has been crushed, animals feces, and bioactivator as an *agent* which could accelerate decomposition. The addition of chalk would increase the pH value and makes decomposition faster (Sutanto, 2002).

Organic waste could be found in a lot amount around us and was still considered as an unuseful waste and bothered our environment. Organic matter was biological material that may be converted into organic fertilizer and animal food. If it would be make for fertilizer the size should be decreased as small as possible to widen the surface area for microorganism to fermented. The same process should be done in making animal feed, the smaller the size the better the digestion process in the animal stomach (Lembaga Pengembangan Teknologi Pedesaan, 2011). Plant residues crushing machines have been created start from the capacity of 230 kg/hour to 1200 kg/hour. Basically, the main components of the machines were hopper, crushing knives, power transmission, frame/body, and power unit. Hopper was a which functioned as a storing box and feed the crushing cylinder with plant residues and crushing knives which functioned to crush the organic materials become as small as possible. The shape of the knife was similar to blade shape and they were connected to the shaft by welding. Power transmission used a *belt-pulley*, while the power unit could be generated by a gasoline or diesel engine. Power unit size was chosen based on the work load that would be done. The bigger the load the bigger the power unit should be used. Lembaga Pengembangan Teknologi Pedesaan (LPTP) Surakarta has fabricated an organic waste crusher with a capacity of 725 kg/h powered by a 24-HP diesel engine. This machine has 6 knives. PT. Agro Tunas Teknik fabricated a crushing machine with a capacity of 1200-2000 kg/hour rotated by an engine of 10.5 HP and fuel consumption 1.5 litres to 2,0 litres per hour. The main problem of these two machines was that the material often plugged between knives and concave. If it happened the engine stopped and it took much time to remove the plugged-material. Paddy straw and palmoil empty fruit bunch were the most difficult materials to be crushed using knife-crushes. These two plant residues have long fiber so that they are difficult to be crushed. Pohan (2008) stated that palmoil empty fruit bunch contained long and strong fiber. These fiber was

very difficult to cut and took a long time to decompose. The fiber tended to be plugged between the knives and concave when were being cut. In case of too much load to the machine the engine stopped. The knives could break due to the age where knives are connected to the shaft by welding (Appendix 1).

A palmoil empty fruit bunch crusher was designed to overcome this difficulties. Eleven rotary saws were replaced the knives used at the previous machine. Rotary saw was usually used at the saw mill or building material to process log wood into several sizes replaced the knives. There were 11 rotary saws put at a shaft and among them were placed eleven spacers (Appendix 2). The spacers also fungtioned as flywheel that kept the moment inertia. The hopper with trapezium shape was installed so that the palmoil empty fruit bunch was directly sawed by the rotary saws. The yield fell into a bucket in small size. It worked successful and could cut another hard plant residus like cassava and acacia. But, it could not be used for plant residues with long fiber like corn and paddy. They plugged around the saws (Tunggal et al, 2011). Based on this experience, the arrangement of the rotary saws and the concave were modified to destroy paddy straw. The distance between one rotary saw and another was 10 cm and the there were 5 metal rods welded to the below side of the concave. On the left and right side of every saw were installed 2 cm plates in thickness used bolts to strengthen saws. The cylinder was rotated using a 7.5 HP diesel engine by belt-pulley transmission. The concave was used as a base in destroying the plant residues. In this design, paddy straw was successfully changed into fine size. The maximum cylinder speed that could be reached was 1300 revolution per minute (RPM). If the speed was over 1300 RPM the belt would vibrate very hard and was dangerous for operator (Appendix 3). The result of this research were the effective capacity was 206,2 kg/h, the size was irregular both in size and shape, total weight of the machine 112 kg, diesel fuel consumption 0,9 liter per hour, and the average speed was 812 RPM (Tunggal and Panggabean, 2012).

Direct transmission has higher efficiency compared with the others, especially when the power source rotates the permanent load. In this mode of transmission the shaft of the power source was connected in-line with the functional part of the machine. The example for this connection was a generator set where the shaft of the engine was directly connected to the shaft of the dynamo. Learned from this case, it was possible to be applied to the crushing machine with a modification. In this experiment, the connector used a rubber conveyor that usually used for coal transportation. The

connector consisted 3 pieces rubber conveyor with 40 cm in length and 15 cm in width. At the engine part and crushing cylinder placed a round metal sheet with 1 cm in thick and 15 cm in diameter. There were 6 holes to connect the three rubber to the round metal sheet. Rubber sheet was chosen because it was elastic and could compensate a shock.

Materials and Method

Method

This research was conducted by Problem-Solving Methodology, that consisted of the following steps: Definition of the problem, Gathering of information, Generation of alternative solutions, Evaluation of alternatives and decision making, Communication of the results

1. Definition of the Problem.

One of the main problems in organic fertilizer production is the crushing process. Many types of crushers have been created and fabricated by companies but weakness found at junction between shaft and knives. The knives were jointed to the shaft by welding. They often broke because the weld-joint was not so strong could not resist the impact of the plant residue. The other problem that was found the knives would be blint due to usage. By this experience, it could be concluded that there were two main problems found at the knife-type crushers, they were joint part and sharpness of the knives.

2. Gathering Information.

There was a competition between farmers and big plantation to obtain chemical fertilizers (Urea, TSP, and KCl). The perennial crops like rubber and palmoil needed much fertilizers to grow. The acreage for these crops grew very fast. As a result, some of the fertilizers that should be used for paddy was bought by perennial crop farmer. On the other hand, paddy farmers have not used to apply organic fertilizer.

3. Generation of alternative solutions.

Concept Generation is the use of creativity-stimulation methods, the application of physical principles and qualitative reasoning, and the ability to find and use information. Experience helped greatly in designing the machine. Road map of my

previous researches gave much inspiration. The ability to generate high-quality alternative solutions is vital to a successful design.

4. Evaluation of alternatives and decision making

The evaluation of alternatives involves systematic methods for selecting the best among several concepts, often in the face of incomplete information. Several alternatives were discussed and then chosen the best one based on possibilities like machine efficiency, machine weight, strength, safety, and ergonomics factors.

5. Communication of the results.

The purpose of the design is to satisfy the needs of a customer or users. For this reason, the finalized design must be properly communicated. The communication is usually by oral presentation to the sponsor as well as by a written design report.

Materials

Materials that were used There were two main parts of the machine, they were structural and functional parts.

1. Structural Part.

The structural parts of the machine were:

a. Frame

Frame was made of a rectangle iron with 2.0 mm in thick and 1.5 inch of sides.

Welding was used to joint one piece of metal to another.

b. Concave

Concave was a part of the machine that acted as a “housing” of the rotary saws. It was formed in cylinder shape made of 3 mm metal sheet. The cylinder was divided into two parts in the same size. One-half at the top functioned to flow plant material to the next knife, and one half at the below part functioned as an anvil to destroy the plant material. At the right end of the cylinder, the crushed plant thrown out through an outlet.

c. Hopper.

Hopper is a box-type tunnel where the plant residue was loaded and felt into crushing chamber.

d. Outlet

Outlet is a hole where the plant residues tha has been crushed throws out. It is located at the below right side of the cylinder.

2. Functional Part

Functional parts of the machine were:

a. Crushing cylinder.

Crushing cylinder was a chamber where plant residues was torned into small pieces. A screw shaft functioned as the heart of the rotary saws. Every rotary saw had a hole at the center and the shaft was inserted to this hole. An arrangement was form when 11 rotary saws were inserted.

b. Bearing.

Bearing was a machine element that eliminated shearing force between two moving parts. Two bearings were used at this machine, one was installed at the left side and the second was installed at the right side next to flange.

c. Power transmission.

The power transmission used was not any power transmission types commonly used at any machine. It consisted of two meta flange with 1 cm in thick and 15 cm in diameter. Three strenghten sheet rubber with 30 cm in length and 10 cm in width were connected the flanges.

d. Engine.

Diesel Engine was chosen as a power source to rotate cylinder.

3. Test of the crusher

A test should be done before machine used. First, it was tested without load to ensure that all component worked well. Before the engine was cranked, check all parts of that machine like loosing nut, lubricant, radiator, fuel, and air cleaner whether they were in proper condition. After that cranked the engine and pay attention to the strange noise when the engine was running. If there was a strange noise it meant a nut or bolt might be not fastened properly and fastened it. The test could be continuoed when the machine was ready.

The test procedure was as follows:

1. Paddy straw was prepared as much as 50 kg at 14 percent moisture content (It was dried at room temperature for 1 month).
2. Engine was cranked and let it run for about 15 minutes to make sure the engine run well.
3. Paddy straw was thrown into the hopper little by little.
4. The time needed to crush 50 kg paddy straw was recorded using stopwatch.
5. To calculate the material capacity, devide the material that could be crushed with the time needed.

RESULTS AND DISCUSSION

A. RESULTS

1. Machine Performance

The design of the machine was presented in Appendix 1 and 2. To ensure the safety operation, check all parts of the machine if there was a loss nut. Check also the oil level of the engine, fuel tank, radiator water, and air cleaner. Cranked the engine and let it run for about 15 minutes. Paddy straw was thrown into the crushing chamber little by little continuously. The crushed paddy straw was come out through the outlet port and went into the bag.

The machine could operate well and there was no any trouble in this step. The vibration was lower than the previous machine (Tunggal and Panggabean, 2012). The maximum speed that could be reached was 2100 revolution per minute (the engine gas stick was at the maximum point) compared with the previous research that could rotate only 1300 rpm. Fuel consumption of the engine was 0.85 litre per hour and the size of the paddy straw was between 2.0 mm to 6.0 mm and the dominan size was 3.2 mm (about 80 %). This result fulfilled the Standar Nasional Indonesia (SNI) for organic matter size for good composting process.

2. Test Results

Paddy straw was used in this research as mush as 50 kg. In South Sumatera, this material has not been used for organic fertilizer. Farmer just burned it if has been dry. Producing organic fertilizer from paddy straw has not been a common activity. The test result showed that the average effective material capacity could be seen at Table 1.

Table 1. Test result of rotary saw crusher at paddy straw

No	Size	Total
1	Less than 0.5 cm	21 %
2	0.5 – 1.0 cm	28 %
3	2.0 – 5.0 cm	15 %
4	More than 5.0 cm	36%

B. DISCUSSION

The main purpose was to design a plant residue crusher to change organic matter size as small as possible so that it took less time in decomposing process. Based on the test result at 1300 revolution per minute the material capacity was 190.6 kg per hour. Compared with the previous machine (Tunggal and Panggabean, 2012) the material capacity was lower at the same cylinder speed. But, the maximum speed that could be reached was much more higher; that was 2100 revolution per minute. There was 64 percent of the crushed paddy straw fulfilled the SNI for decomposition.

Cylinder speed and feeding speed were the main factors that affected material capacity. The faster cylinder speed the higher the material capacity, and the faster the feeding raw material the material capacity increased. Rubber sheet that connected cylinder shaft and engine functioned better than belt-pulley transmission. It was also easier to crank the engine compared with the previous design.

In fact, farmers had understood how to make organic fertilizer and know the advantages of the organic fertilizer either for human or environment. In Java Island paddy straw was utilized for livestock. Different from Javaness farmers, South Sumatera farmers burned the paddy straw residues and gave their livestock with green grass. The result of this research could also be tried as a mixture of concentrate for livestock feed.

CONCLUSION

Shaft to shaft transmission could be applied to the paddy straw crusher and the performance was better than belt-pulley transmission in case of material size, cylinder speed, and more compact in shape.

REFERENCES

- Basedow, Thies. 2003. *Problems, Possibilities and Limits of Ecological Farming*. Proceedings of the International Seminar on the **Organic Farming and Sustainable Agriculture** in the Tropics and Subtropics: Science, Technology, Management and Social Welfare. Palembang
- CV Gatra Adhiguna. 2009. Report of developing of organic fertilizer in Musi Banyuasin District, South Sumatera, 2009. Dinas Pertanian dan Peternakan Kabupaten Musi Banyuasin, Sumatera Selatan. Sekayu. **Unpublished**.
- LPTP Surakarta. 2011. Mesin Penghancur Sampah Organik 2. LPTP Surakarta. Browsing from <http://www.lptp.or.id/webpage.php> July 6th, 2011.
- Pohan, I. 2008. *Panduan Lengkap Kelapa Sawit*. Panebar Swadaya. Yogyakarta.

PT. Agro Tunas Teknik. 2009. Penghancur Sampah Organik. PT. Agro Tunas Teknik, Bekasi. Browsed from <http://www.agrotunasteknik.com/> , July 9th 2011.

Saragih, S.E. 2008. *Pertanian Organik*. Penebar Swadaya, Yogyakarta.

Sutanto, R. 2002. *Pertanian Organik*. Kanisius. Yogyakarta.

Tunggal, T; Hasbi, dan K. Hutapea. 2011. Prosiding Seminar Nasional Perteta 2011 at UNEJ Jember.

Tunggal, T and T. Panggabean. 2012. Prosiding Seminar Nasional Perteta 2012 at Brawijaya University, Malang.

APPENDIX



Appendix 1. Plant residue crusher knife type using belt-pulley transmission



Appendix 2. Palmoil empty fruit bunch circular saw crusher using belt-pulley transmission

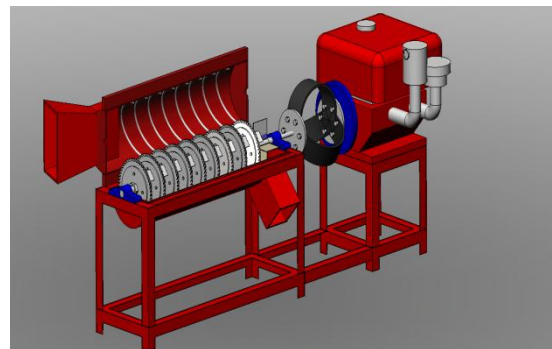
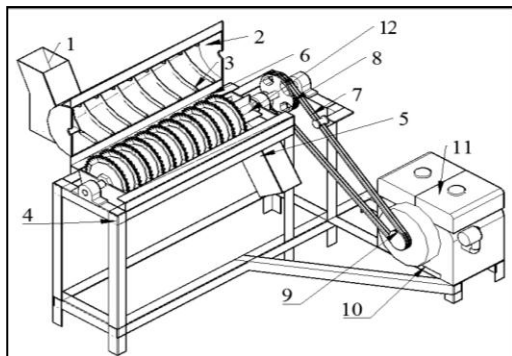

Appendix 3. Technical drawing of previous design of circular saw crusher using belt-pulley transmission

Appendix 4. Photograph of the latest design of circular saw crusher using rubber-flange transmission

