

PAPER • OPEN ACCESS

Water Management Planning for Swamp Buffalo in Sub-District Rambutan, Banyuasin Regency

To cite this article: Andre Wibowo *et al* 2019 *J. Phys.: Conf. Ser.* **1198** 082027

View the [article online](#) for updates and enhancements.



IOP | ebooks™

Bringing you innovative digital publishing with leading voices to create your essential collection of books in STEM research.

Start exploring the [collection](#) - download the first chapter of every title for free.

Water Management Planning for Swamp Buffalo in Sub-District Rambutan, Banyuasin Regency

Andre Wibowo, Dinar Dwi Anugrah Putranto*, Sarino

Department of Civil Engineering, Faculty of Engineering, Universitas Sriwijaya, Palembang, Indonesia 30128

Email: dwianugrah@yahoo.co.id

Abstract. The swamp is a water storage with a water resources contained, constantly or seasonally inundated, naturally formed in relatively flat or concave land with mineral or peat deposits, and overgrown with vegetation, which is an ecosystem [1]. Utilization of swamp land in Rambutan, Banyuasin district has not been optimal, in the study site has been a lot of research on buffalo that said the need for a water management system in the dry season. This study aims to analyze the water availability for buffalo, analyze the water requirements for buffaloes, plan the water management system for swamp buffalo of Rambutan Sub-District at South Sumatra, so during the dry season the water demands for feed and buffalo habitat are fulfilled as well. In this study water management planning scenarios for swamp buffalo cattle include: analyzing the minimum discharge for water availability, analyzing the water requirements for livestock and ponds, planning drainage ditches and ponds as water demands for swamp buffaloes. The lowest water level was at -0.508 MSL. With a river discharge of 14.64 m³ / sec, the highest water requirement occurred in July of 541,559.8 m³ and the lowest in August of 437714.3 m³, the channel can overcome the fulfillment of water buffalo at the location of research.

Keyword: Swamp Buffalo, Water availability, Water requirements for buffaloes, Water system for buffaloes

1. Introduction

Swamp areas in Banyuasin its particular only limited in agriculture and fishery according to BPS data [2] rice field in the swamp area that has been developed for 226.518 Ha which produce 1.4 million tons of rice. Whereas in the sense, swamp reclamation is a method of swampland development using hydraulic technology in the form of a swamp reclamation network [3]. In Rambutan Sub-district, Banyuasin Regency of South Sumatera, there is a low land swamp as a buffalo cattle, this buffalo type is also called swamp buffalo, swamp buffalo which is one of the richness of germplasm in South Sumatera in study environment of swamp buffalo already exist, but still simple, a minimum of infrastructure and so dependent on nature that the buffalo development has not been optimized yet, previous studies have shown that buffalo without wallowing shows that their weight gain is much lower than that of wallowing buffaloes. Devoted to the interests of buffaloes there has never been any irrigation development, this happened apply almost all areas of the country. Consequently, ruminants' livestock business is dimmed in the future, therefore there needs to be a good water governance system in the dry season, water governance is a good water management system so that the availability of feed and pond puddles in the dry season.



The research location is at 104°56'36" to 104°57'20" east longitude and 3°6'40" up to 3°7'30" south latitude with a total area of 199 Ha. Research location is included in the category lowland swamp for 6 months.

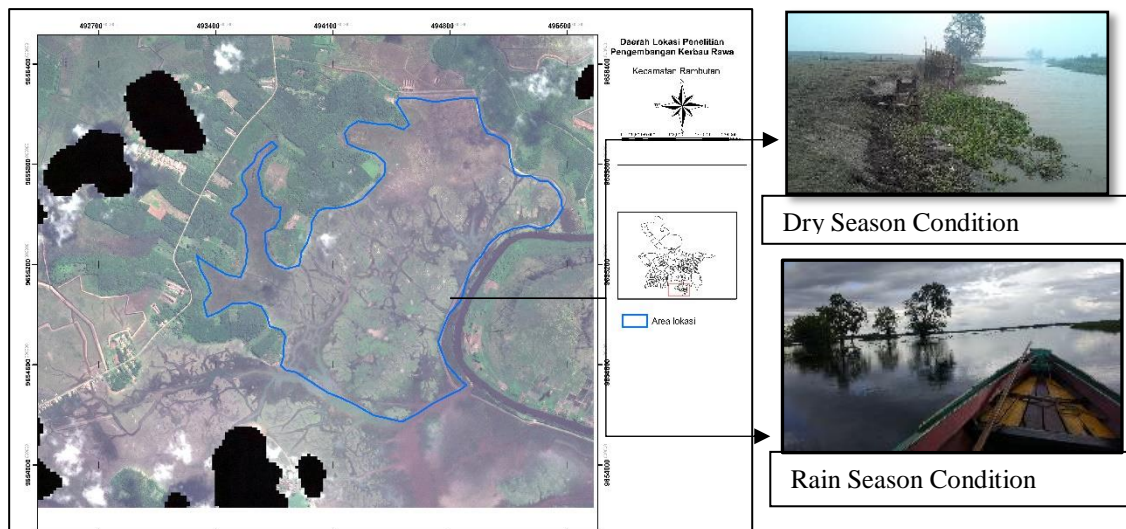

Figure 1. Location and Condition of Research Areas

The water level observation is conducted to determine the available discharge in the river, the water level elevation using peischaal and the tool to measure the speed by using the buoy and stopwatch. [4] To correct the data already obtained in the field need to be tied to the nearest point of bench mark, so that the recording of water level data into a system with topographic measurement of land. River water level observations were conducted twice in October during the dry season of 2015 and during the rainy season in May 2018, while river flow velocity measurements were carried out in the rainy season, river water level observations and current velocities were used to determine the discharge at river

2. Research Methodology

Discharge is the volume of flow through a river cross section in units of time [5]. The flow debit obtained from the observation of the river water and the topography of the river, the wet sectional area is obtained, then multiplied by the current velocity so that it is known that the formula of water discharge used is:

$$Q = \Sigma(A \times V) \quad (1)$$

Where:

- Q = Discharge (m³/s)
- V = Average velocity
- A = Area of wet section (m²)

$$v = \frac{1}{n} \times R^{2/3} \times i^{1/2} \quad (2)$$

Where:

- n = coefficient of roughness
- i = water surface gradient
- R = $\frac{A}{P}$ (m) = hidrolis radius
- P = wet circumference (m)

The water demand for buffaloes is three i.e. water demand for feed, daily water requirement and water demand for wallowing, if the projected growth of buffalo population exceeds the existing land capacity then buffalo based on the capacity of the land as green fodder based on the level of water requirement for buffalo based on the vast capacity area of the pasture area

Analyzing the requirement of forage space for fodder is useful to get the number of buffalo that can be accommodated in the research location so that the maximum number of buffalo buffer in the study location, [7]

$$Pt = \frac{Ap \times ProdR}{Kp} \quad (3)$$

Where:

- Ap = Area of Shepherding (ha)
- Pt = Number of buffaloes (buffaloes)
- Prod = Grass productivity (ton/ha)
- Kp = Feed requirement (ton)

Analyzing the number of buffaloes multiplied by the need of clean water per day for buffalo, water requirement for cows or buffaloes of 40 ltr / sec / day [8], the following:

$$Qk = Pt \times Qkeb \quad (4)$$

Where:

- Qk = Need for clean water buffalo (litres/sec)
- Pt = Number of buffaloes (buffaloes)
- Qkeb = Water buffalo needs per day (litres/sec/day)

Analyze Fodder forage water requirements are used using evapotranspiration (Eto) penman method, plant coefficient (kc) and Effective Rain (Re) [9]

$$Etc = ETo \times Kc \quad (5)$$

Where:

- ETc = Potential evapotranspiration
- ETo = evapotranspiration
- Kc = Coefficient of plant

$$NFR = Etc - Re \quad (6)$$

Where:

- ETc = Potential evapotranspiration
- ETo = evapotranspiration
- NFR = Need for irrigation water
- Re = Effective Rain

During bathing swamp buffalo dipping the entire body parts except the head, so water level for buffalo wallowing using the approach that the height of water level as high as the shoulders of buffalo its between 129.7 ± 7.3 cm, the width of pond water per one buffalo about 4 m^2 [8].

The water balance in a pond is a hydrological cycle in a pool that is evaluated with incoming water and water coming out in a pond for a certain period. The equilibrium formula of water is presented in equation 7

$$\Delta V / \Delta t = \text{flow discharge} + \text{rain} - \text{ET} - \text{infiltration} - \text{seepage} - \text{outflow} \quad (7)$$

To know the pond volume reservoirs from buffalo number and buffalo behavior pattern to wallow by using formula of capacity of pond

$$Vn = Vu + Ve + Vi + Vs \quad (8)$$

Which is:

- Vn = Total pond volume (m^3)
- Vu = Volume to serve the needs (m^3)
- Ve = Volume of water losses due to evaporation (m^3)
- Vi = Volume of absorption through bottom, wall, and body of pond (m^3)

The existing discharges for water needs must be channeled to the maximum so that there should be an appropriate channel dimension plan, the channel dimension plan must be able to flow at least must be the same or greater the discharge of the needs plan that is analyzed. For drainage of irradiated trapezoidal cross-section irrigation has no economical common advantages, [9] the determination of the channel dimension plan itself applied Stickler approach as in equation 2

3. Result and discussion

3.1. Watershed characteristics analysis

Based on water level observation data and river flow velocity, the water discharge is available in the river, then made a momentary flow of river flow, then the momentary debit arch graph can be seen in Figure 2

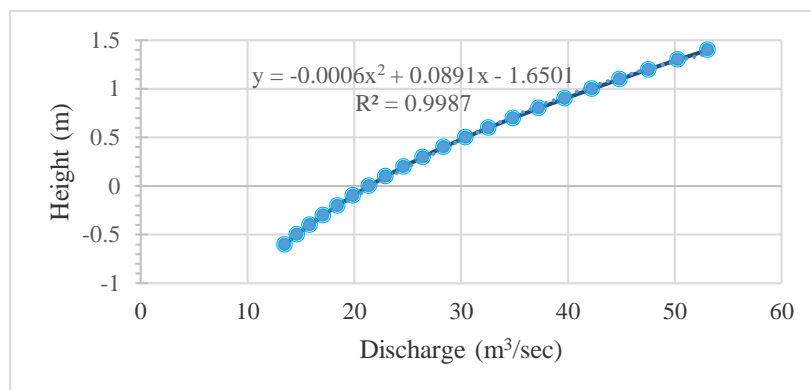

Figure 2. Curve of instantaneous discharge curve

From the observation of river water height, the lowest observation elevation -0,508 then get the discharge equal to 14,64 m³/sec.

3.2. Water Demands Analysis for Buffalo

Daily water buffalo needs based on the number of buffaloes that can be accommodated in the area of research location with grass production capacity of 15.6 tons / ha per 90 days then the buffalo with an area of 199 ha amounted to 848 buffalo, so the water buffalo requirement of 4139200.0 ltr per 4 months dry season.

The need for forage for fodder will be more and more with the growing population of livestock problems that occur is when the rainy season of production is low but in the dry season the production decreases or does not exist at all. Evapotranspiration calculations use the Penman modification method by entering climatological data. For evapotranspiration calculations are presented in Figure 3.

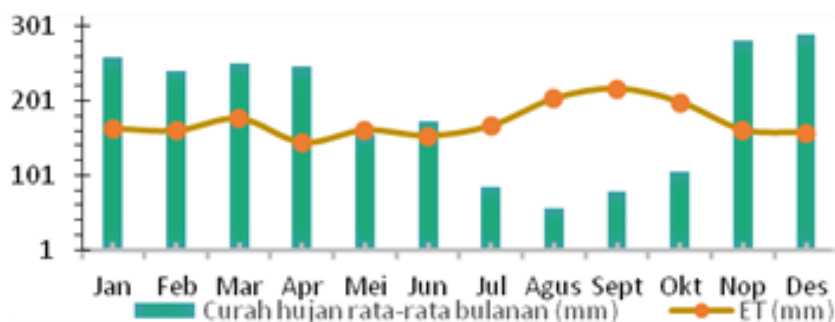

Figure 3. Monthly Evapotranspiration dan Rain Average

From the highest monthly evapotranspiration calculation in October was 212.346 mm / month while the lowest evaporation in June was 146,118 mm / month. Effective rain is calculated by using the probability formula that 70% of rainfall is 50% probable. The results of the calculation can be seen in the results of the analysis below. Can be seen in table 4.

The analysis was done by the result of the Water Consumption Needs of Consumptive Plants (etc.) reduced by Effective Rain (Reff) analysis was conducted in July until October due to the dry land. The calculation of crop water requirements can be seen in Table 1.

Table 1. Water requirement for plants

No	Deskripsi	JUL	AUG	SEP	OCT
1	Eto (mm/month)	180.7	113.3	133.4	142.4
2	Kc	1.05	1.05	1.05	1.05
3	Etc (mm/month)	189.7	119.0	140.1	149.5
4	Etc (mm/day)	6.1	3.8	4.7	4.8
5	Re (mm/day)	0.6	0.0	0.0	0.6
6	Perkolasi (mm)	3.0	3.0	3.0	3.0
7	Water demand (mm/day)	8.5	6.8	7.6	7.2
8	NRF (ltr/sec/ha)	0.982	0.791	0.885	0.835
9	Wide Area (ha)	199.0	199.0	199.0	199.0
10	Plants water needs (ltr/sec)	195.51	157.50	176.03	166.12
11	Plants Water Needs (m ³ /month)	523,657.2	421,850.7	456,263.2	444,940.8

With an immersion height of 1.37 meters and a space requirement of 4 m² multiplied by the number of buffaloes obtained the volume of pond for buffalo that is equal to 4648.12 m³. Following the total requirement of swamp buffalo water is obtained from the cumulative of water requirement everyday added with water demand for pasture and water requirement for buffalo wallowing can be seen in Table 2.

Table 2. Water Requirement for Swamp Buffalo

No	Description	July	August	September	October
1	Water for daily needs (m ³)	1,051.76	1,051.76	1,017.84	1,051.76
2	Water needs for HMT (m ³)	523,657.17	421,850.71	456,263.15	444,940.77
3	Water needs for pond (m ³)	4,648.12	4,648.12	4,648.12	4,648.12
4	Total Volume (m ³)	529,357.05	427,550.59	461,929.11	450,640.65

3.3. Analysis of wallowing pond dimensions

The dimension of pond pool is based on the need of water for buffalo wallow, determination elevation of pond bottom plan (m) = minimum water level of river (m) - height of buffalo immersion (m) - high guard (m) = -0,5 - 1,37 - 0,5 = - 2,37 meters, the minimum pool area can be calculated by the area of immersion space per one buffalo multiplied by the number of buffaloes that is equal to 3398 m²

The following volume of pond pool pools planned can be seen in Table 3. The relationship of elevation and volume of ponds

Table 3. Relation between elevation and volume

Elevation (m)	Area of Water Surface (M ²)	Amount of Water Surface (M ²)	H (m)	Pond Volume (m ³)	Cumulati ve pond volume (m ³)
-2.4	11806.9				0.0
		12647.9	0.4	4890.0	
-2.0	12647.9				4890.0
		25295.8	0.5	6593.8	
-1.5	13734.6				11483.8
		39030.4	0.3	4220.6	
-1.2	14405.4				15704.4
		53435.9	0.2	2926.5	
-1.0	14860.5				18630.8
		53891.0	0.5	7719.7	
-0.5	16025.7				26350.6
		69916.7	0.5	8312.2	
0.0	17230.2				34662.7

Based on the volume above is continued by using the equilibrium formula of water as existing equation 8, following the water balance that occurs in the pond, can be seen in table 4. the following:

Table 4. Pond Water Balance

Month	Description					
	P (mm/month)	Vu (m ³ /month)	Vi (m ³ /month)	Ve (m ³ /month)	V Total (m ³)	Deficit (m ³)
July	1348.4	529,357.1	11,028.3	1,174.5	541559.8	-540,211.4
August	905.5	427,550.6	8,907.3	1,256.4	437714.3	-436,808.9
September	1560.1	461,929.1	9,623.5	1,348.0	472900.6	-471,340.5
October	2060.9	450,640.7	9,388.3	904.0	460932.9	-458,872.0

From the above analysis and from the design of the existing pool plan to meet the needs of buffalo water if only using a pool of storage and rain that goes into the pool will not be able to meet the existing water needs, it is necessary channel plan as the discharge into the pond.

3.4. Channel dimension analysis

Channel plan analysis is needed to drain Padang river water as water supply to meet buffalo requirement, plan debit is 0.4 m³ / sec with flow rate analyzed by equation 1 and 2. The plan dimension image can be seen in Figure 4.

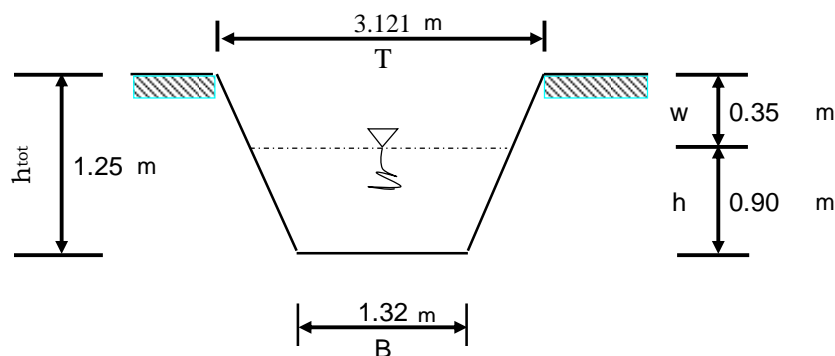
**Figure 4.** Channel Plan Dimensions

Given the addition of a supply channel from the river, the water supply for the buffaloes is reached as described in Figure 5 Water balance after the channel.

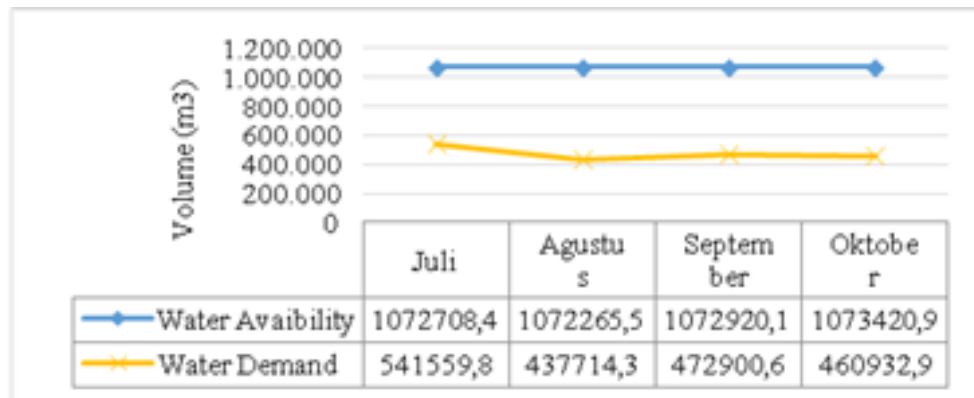

Figure 5. Water Balance

4 Conclusion and Discussion

The conclusions of this research are:

- The lowest water level is at -0.508 MSL with discharge of 14,64 m³/second
- The highest water demand occurred in July of 541,559.8 m³ and the lowest in August of 437714,3 m³.
- With the creation of channels can be to overcome the fulfillment of water buffalo at the location of research.

5 References

- [1] Anonim. 2015. Regulation of the Minister of Public Works and People's Settlement NO. 16 Indonesia
- [2] Central Bureau of Statistics Banyuasin District, 2005-2016. Banyuasin in number, Indonesia.
- [3] Suhubudy. 2007. Feed Provision Strategy for Buffalo Livestock Business Development. Online Journal Center for the Production System of Shepherd Dogs and Tropical (In Indonesia) [4] Soewarno. 1995. Hidrology. Bandung. Nova.
- [5] Sosrodarsono and Takeda, 1993. Hydrology for water resources. Jakarta. Pradnya Paramita [6] Abdullah. 2014. Analysis of Water Demands, Banda Baro District, North Aceh Regency. Online Teras Journal Vol 1 (In Indonesia)
- [7] Soemarto, C.D. 1987. Technique of Hydrology. Surabaya. Usaha Nasional
- [8] Somparn, Gibb and Vajrabukka, 2006, "Wallowing Behaviour of Swamp Buffalo (Bubalus Bubalis) Heifers Under Continues Stocking During The Summer In Northeastern Thailand", Online Buffalo Journal