

study of shear wall

By Livian Teddy

The study of shear wall uses in buildings during the architecture design process

Livian Teddy^{1,2}, Husnul Hidayat¹ and Dessa Andriyali A¹

¹Department of Architecture, Engineering Faculty, Sriwijaya University, Palembang, Indonesia

² Corresponding author: livianteddy@gmail.com

Abstract. In Indonesia, an earthquake-prone area, building designs must be earthquake resistant, and using shear walls is one of the ways to make buildings more earthquake resistant. However, determining the requirements and optimal position of shear walls is difficult. Miscalculating in their positioning can cause torsion and other unpredictable behavior. Previous studies were done to know shear walls' optimal areas and positioning. The first way was trial and error, but this method was ineffective and took a long time. The second way, MATLAB programming, is actually very effective since the needs and orientation of the walls can be determined precisely. Nevertheless, not all structural engineers and architects master the programming language. This study, therefore, proposes relatively simple formulas and procedures to determine the optimal area and positioning of shear walls for architects preliminary design during architecture design process. The accuracy test for the formulas and procedures was carried out using ETABS simulation experiments on 10 building models with various irregular categories. The result showed the formulas and procedures proposed in this study were quite accurate in calculating the needs and position of shear walls. Optimal conditions, furthermore, were quite easy to achieve in symmetrical geometric compositions (1 or 2 axes) while organic or random geometric compositions were quite difficult to achieve. When the use of shear walls achieves optimal condition, the strength and stiffness of a building are increased, and the distribution of its strength and stiffness is relatively even, hence anticipating deformation behavior and reducing building eccentricity.

1. Introduction

In earthquake-prone countries like Indonesia, buildings must be designed to withstand earthquakes. The process of designing earthquake-resistant buildings should be started from the architecture design process by considering the geometric aspects of buildings which eventually affect buildings' structural behavior in carrying lateral earthquake loads [1].

Buildings with regular geometry configurations are relatively more resistant to earthquakes than buildings with irregular geometric configurations when facing earthquakes, particularly the strong ones [2]. The demand for buildings due to population growth and limited locations in big cities eventually causes the occurrence of buildings with irregular configurations [3]. Irregularities in buildings can trigger torsion due to the eccentricity between the center of mass and the center of rigidity. Shear walls are generally used to decrease torsional effects on buildings, and these walls also stiffen and reduce the deformation due to earthquake loads [4]. However, the efficiency of using shear walls heavily depends on their positioning. Getting the optimal shear walls' positions is very difficult, and if these walls are incorrectly placed, it can even trigger greater torsion [5]. To obtain guidance for



² Content from this work may be used under the terms of the Creative Commons Attribution 3.0 licence. Any further distribution of this work must maintain attribution to the author(s) and the title of the work, journal citation and DOI.

the optimal position of the shear walls, several researchers [4–6] conducted trial-and-error simulations with ETABS. This first method was conducted by varying the placement of shear walls in several geometric configurations of irregular buildings, and the results were compared to find out the most optimum position. The optimization, nonetheless, could not be applied to other irregular configurations and the required shear wall areas were also unknown. Several other researchers [7–10] used software such as MATLAB to immediately obtain the optimum position and orientation and the required areas. This method is actually practical, yet not all architects understand this kind of complex matrix programming software.

In order to overcome this obstacle, this study proposes relatively simple formulas and shear wall positioning procedures to obtain the preliminary shear walls' areas and optimal positions. 10 building models with various categories of irregularities were used to test the procedure. The first stage of this simulation was 5 irregular building models without shear walls were analyzed using the ETABS to get the outputs, namely fundamental period, mode, participating ratio, and eccentricity. Based on these outputs, a simple calculation of the shear wall areas was conducted using the proposed shear wall positioning formulas and procedure. The next step is the addition of shear walls to each building model to improve its irregularity and to make it relatively regular. The five irregular building models with shear walls were then analyzed again to find fundamental period, modes, participating ratios, and eccentricity as the outputs. The outputs, both before and after applying shear walls, were compared to determine the accuracy, strengths, and weaknesses of the proposed formulas and procedure. Guidance for architect's preliminary design during architecture design process was then made as the reference in designing buildings' geometry with irregular configurations and in using shear walls to improve the buildings' dynamic behavior to be relatively regular so that it is more resistant to earthquakes.

2. Research methods and models

2.1. Research methods

This research is an experimental simulation study that aims to test the proposed mathematical models and procedures with ETAB's modal analysis and structure analysis software. Such 'testing theory' process is commonly conducted in the field of engineering [11].

The sampling technique employed in the selection of the simulation model was purposive sampling. According to Nasution [12], in purposive sampling, samples are carefully selected so that they are relevant to the research design. Thus, in this research, those 5 simulation models were considered to have relatively varied geometric configurations, so they were able to describe the real irregular geometric configurations.

2.2. Models

The building modules used were 5×5 m. There were 10 building models simulated in the study, namely 5 irregular building models without shear walls (Figures 1 to 5) and five irregular building models with the shear walls (Figures 1A to 5A). The structural properties of each model can be seen in Table 1.

Models 1 to 5 (Figures 1, 3, 5, 7, and 9) used the moment resisting frame structure, while models 1A to 5A (Figures 2, 4, 6, 8, and 10) used the dual system structure with moment resisting frames and shear walls. The simulated earthquake zone was with $S_s = 1.5g$ and $S_1 = 0.6g$ while the building, functioning as an office, had the assumed dead load = 400 kg/m² and the assumed live load = 250 kg/m². Geometrical data, structural properties, and building loads were input into ETABS, and structure analysis and modal analysis were carried out to get the outputs that consist of Period (T), Shape Mode Translation (Ux, Uy), Rotation (Rz), and Centers of Mass and Rigidity.

Period (T) is the fundamental period of a building structure that is used to measure the stiffness level [13]. A building is considered to be rigid if $T < T_{max}$ while it is considered flexible if $T > T_{max}$. The definition of T_{max} is the maximum period allowed in a building based on the values of S_s and S_1 , the type of structure, and the height of the building.

Table 1. Structural properties of Models 1 to 5 and Models 1A to 5A.

Models	Number of floors (height-m)	Dimension beam (cm)	Dimension column (cm)	The thickness of stories (cm)	The thickness of shear wall (cm)	Grade		
						Concrete (kg/cm ²)	Reinforcement (kg/cm ²)	Stirrup (kg/cm ²)
1 & 1A	10 (40 m)	25×40	60×60	12	25	300	4000	2400
2 & 2A	10 (40 m)	25×40	60×60	12	25	300	4000	2400
3 & 3A	7 (28 m)	25×50, 30×60	D 65	12	25	300	4000	2400
4 & 4A	10 (40 m)	25×40	60×60	12	25	300	4000	2400
5 & 5A	10 (40 m)	25×40	60×60	12	25	300	4000	2400

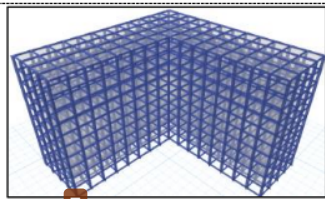

Figure 1. Model 1.

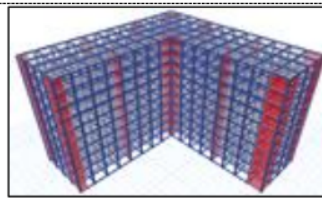

Figure 2. Model 1A.

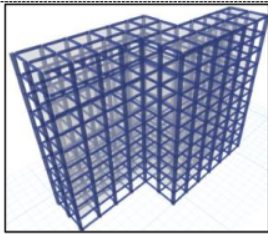

Figure 3. Model 2.

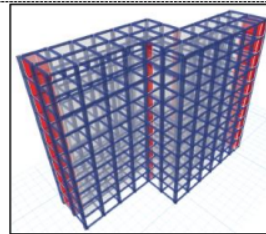

Figure 4. Model 2A.

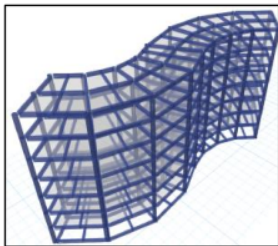

Figure 5. Model 3.

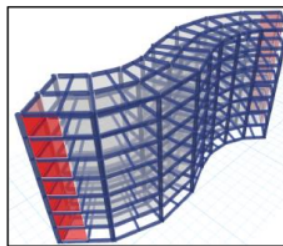

Figure 6. Model 3A.

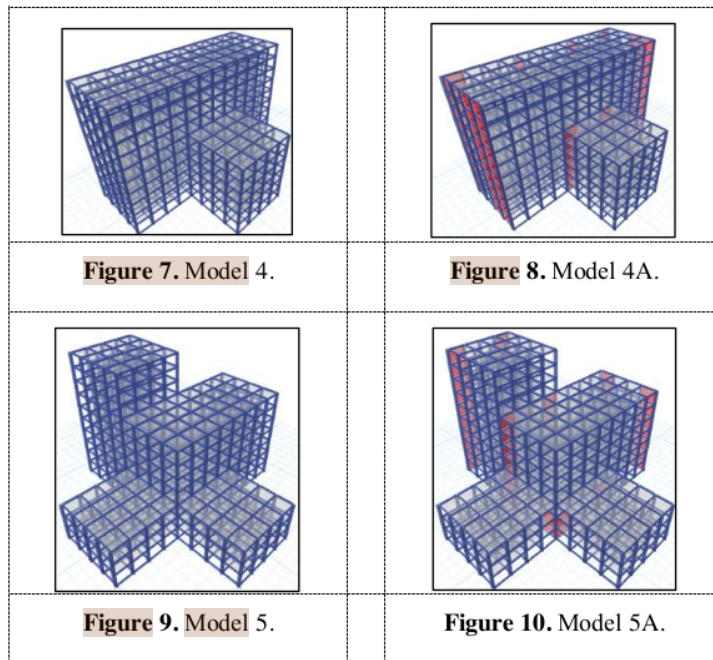

Figure 7. Model 4.

Figure 8. Model 4A.

Figure 9. Model 5.

Figure 10. Model 5A.

Shape mode (U_x , U_y , and R_z) is the variation of deformations that may occur in a building. Shape mode measures buildings' regularity level. Buildings with mode 1 = translation, mode 2 = translation and mode 3 = rotation can be categorized as regular buildings [14]. When the value node 1 to mode 3 is between 0 and 1, which means when it gets closer to 1, translation towards the X-axis and Y-axis and rotation of the Z-axis are dominant.

Centers of mass and rigidity are used to measure the potential level of torsion in a building. Torsion is caused by the eccentricity between the center of mass and the center of rigidity or, in other words, the center of mass does not coincide with the center of rigidity [15]. Eccentricity occurs due to the irregular geometric configuration. Based on the Simplified Vulnerability Analysis (SVA) of Architectural Design [16]; the eccentricity ratio $e_{ri} \leq 0.1$ means potential for small torsion, the eccentricity ratio $0.1 < e_{ri} < 0.3$ means potential for medium torsion, and the eccentricity ratio $e_{ri} \geq 0.3$ means potential for large torsion.

3. The proposed formulas and procedure

There are several steps to take in designing shear walls position in the building:
As the first step, determine the required shear wall area using the formulas below [17].

$$A_{SW} \geq 0.0012 \sum A_{pi} \tag{1}$$

where,

- A_{SW} = The minimum shear wall area per floor
- $\sum A_{pi}$ = The gross cumulative area of floors

For the second step, determine the distribution of shear walls on the building's floors. The positioning and orientation of the shear walls must consider:

- The balance of the plan and position of shear walls in order to avoid the potential for the next greater torsion.

- The relatively equal stiffness between the X- and Y- axes of the plan. The weak axis gets more wall area orientation than the strong axis, so both axes have the relatively same stiffness (see Figure 11).

$$A_{SW-X} = \frac{Y}{(X + Y)} \cdot A_{SW} \tag{2}$$

$$A_{SW-Y} = \frac{X}{(X + Y)} \cdot A_{SW} \tag{3}$$

where,

A_{SW} = The minimum shear wall area per floor

A_{SWX} = The shear wall area of the X-axis

A_{SWY} = The shear wall area of the Y-axis

Y & X = The building dimension towards X- and Y-axes

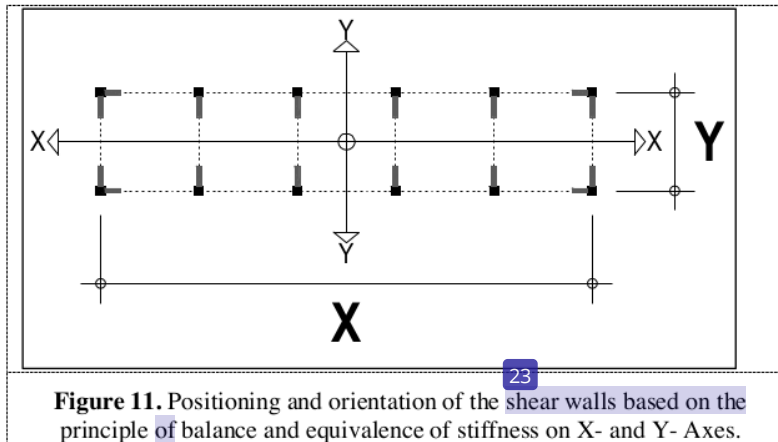

Figure 11. Positioning and orientation of the shear walls based on the principle of balance and equivalence of stiffness on X- and Y- Axes.

For the third step, simplify the complex plan (Figure 12) by dividing it into several blocks of rectangular plans so that they can also be analyzed using the previous second step.

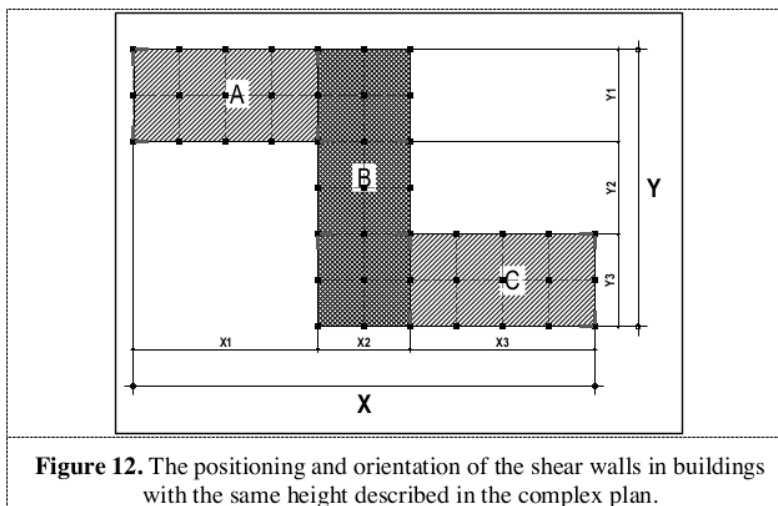

Figure 12. The positioning and orientation of the shear walls in buildings with the same height described in the complex plan.

- With the formulas below, calculate the proportional shear wall area of each block. Blocks with larger plans also have larger shear walls and vice versa:

$$A_{SW-A} = \frac{L_A}{(L_A + L_B + L_C)} \cdot A_{SW} \quad (4)$$

$$A_{SW-B} = \frac{L_B}{(L_A + L_B + L_C)} \cdot A_{SW} \quad (5)$$

$$A_{SW-C} = \frac{L_C}{(L_A + L_B + L_C)} \cdot A_{SW} \quad (6)$$

where,

$A_{SW-A}, A_{SW-B}, A_{SW-C}$ = The shear wall areas in A, B, and C blocks.

L_A, L_B, L_C = The areas of blocks A, B, and C.

- After the shear wall area of each block is found, determine this shear wall area on each X- and Y- axes based on formulas 2 and 3:

$$\text{Blok A} \rightarrow A_{SW-AX} = \frac{Y1}{(Y1 + X1)} \cdot A_{SW-A} \quad (7)$$

$$A_{SW-AY} = \frac{X1}{(Y1 + X1)} \cdot A_{SW-A} \quad (8)$$

$$\text{Blok B} \rightarrow A_{SW-BX} = \frac{Y}{(Y + X2)} \cdot A_{SW-B} \quad (9)$$

$$A_{SW-BY} = \frac{X2}{(Y + X2)} \cdot A_{SW-B} \quad (10)$$

$$\text{Blok C} \rightarrow A_{SW-CX} = \frac{Y3}{(Y3 + X3)} \cdot A_{SW-C} \quad (11)$$

$$A_{SW-CY} = \frac{X3}{(Y3 + X3)} \cdot A_{SW-C} \quad (12)$$

where,

$A_{SW-AX}, A_{SW-BX}, A_{SW-CX}$ = Shear wall areas on the X-axis of blocks A, B, and C

$A_{SW-AY}, A_{SW-BY}, A_{SW-CY}$ = Shear wall areas on the Y-axis blocks A, B, and C

In the fourth step, for the complex plan where the buildings have significantly different heights, separately calculate the shear wall areas of each mass block that have different heights according to steps 2 or 3 based on the mass composition and the heights.

In the fifth step, to find out the number and length of shear walls, divide the shear wall areas from formulas 2, 3, and 7 to 12 on each X- and Y- axes by the number of shear walls that will be distributed to each axis. Furthermore, to determine the length, the aforementioned shear wall areas are divided by the shear wall thickness (min = 25 cm). There are several ideal distributions of shear wall locations [18–21], namely on the corners of the building (Figure 13a), along the sides of the building if > 30 m (Figure 13b), at the intersection of building masses (Figure 13c) and at the core of the building (Figure 13d). All of these locations can increase the structural rigidity and strength and reduce torsion, and they can also be installed either separately or together.

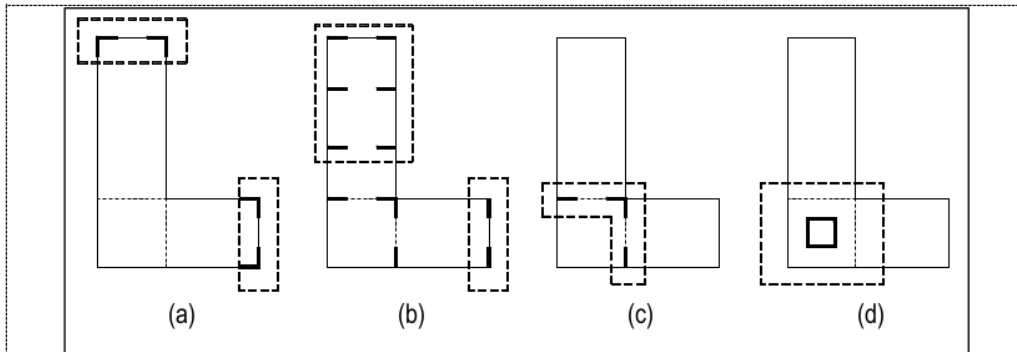

Figure 13. The ideal positioning of shear walls: a) on the corners, b) on the sides, c) at the intersection of building masses, and d). at the building's core.

4. Results and discussions

4.1. Models 1 and 1A

Model 1 (Figure 1) was installed with shear walls and became model 1A (Figure 14). For the calculation of shear walls, the building mass was divided into mass A and mass B. With formulas 19, 12, it was found that the need of mass A for shear walls was 6×5 m on the X-axis and 4×2.4 m and 6×5 m on the Y-axis. The need of mass B for shear walls, on the other hand, was 6×5 m on the X-axis and 2×5 m on the Y-axis.

The addition of shear walls also increased the building's stiffness by reducing the fundamental period of model 1. Before using shear walls, its fundamental period was 1.921 seconds (Table 2a), and after using shear walls, its fundamental period was 1.008 seconds (Table 2b). This period is also still below the required $T_{max} = 1.09$ seconds.

Based on the shape mode in model 1, modes 1 and 2 had the same translation value and were not dominant while mode -3 was rotation and dominant (Table 2a). This means that the occurring translation on both Y- and X- axes is not uniform or there is a diagonal translation. Thus, model 1 can be categorized as an irregular building. In order to improve its deformation behavior, shear walls were placed in model 1A on the building's corners, on the building's sides, and at the intersection of mass A and mass B. The deformation behavior, then, significantly improved in which modes 1 and 2 = translation and dominant and mode 3 = rotation and dominant (Table 2b). Model 1A, hence, can be categorized as a regular building.

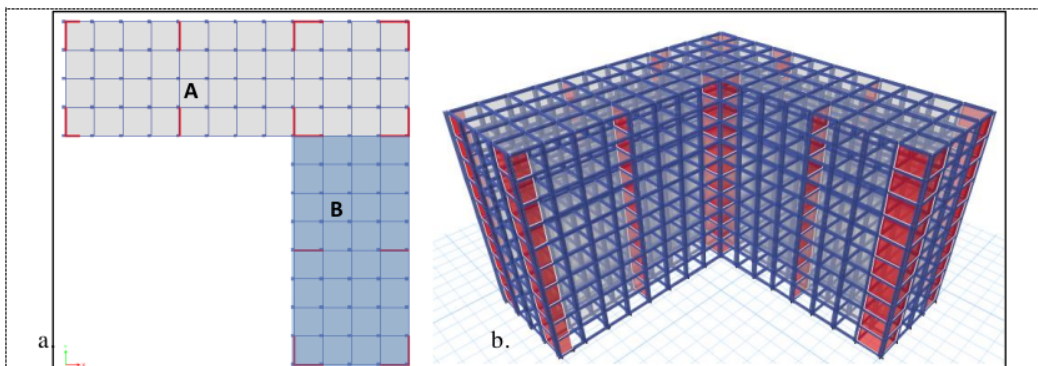

Figure 14. Model 1A (after shear walls were installed): a) the plan, b) 3D.

Table 2. Modal direction factors of Models 1 and 1A.

a). Model 1					b). Model 1A				
Mode	Period (s)	UX	UY	RZ	Mode	Period (s)	UX	UY	RZ
1	1.921	0.418	0.418	0.164	1	1.008	0.941	0.006	0.053
2	1.908	0.500	0.500	0	2	0.939	0.009	0.988	0.003
3	1.842	0.083	0.083	0.835	3	0.752	0.005	0.006	0.944

Table 3. Eccentricity ratios of Models 1 and 1A.

Stories	Model 1		Model 1A	
	e_{rx}	e_{ry}	e_{rx}	e_{ry}
Storey10	0.013	0.013	0.016	0.062
Storey9	0.013	0.013	0.018	0.063
Storey8	0.012	0.012	0.020	0.066
Storey7	0.011	0.011	0.022	0.071
Storey6	0.011	0.011	0.025	0.076
Storey5	0.010	0.010	0.028	0.082
Storey4	0.009	0.009	0.034	0.088
Storey3	0.008	0.008	0.041	0.094
Storey2	0.006	0.006	0.051	0.098
Storey1	0.002	0.002	0.059	0.093

The eccentricity ratio of model 1 was e_{rx} and $e_{ry} < 0.1$ which means that the potential for rotation is small. After the addition of shear walls, the eccentricity ratio of model 1A was e_{rx} and $e_{ry} < 0.1$ or, in other words, the positioning of shear walls was optimal. When the positioning is optimal, it does not cause excessive eccentricity which may cause torsional irregularity configurations [22]. Besides, the main problem of model 1A was the formation of the re-entrant corner irregularity configuration [22]. This condition actually can cause the concentration of forces at the intersection of mass A and mass B, but the presence of shear walls at the intersection can also increase the capacity of the structures to encounter that force concentration.

4.2. Models 2 and 2A

Model 2A (Figure 15) was actually model 2 (Figure 3) after the shear walls, and core walls were installed. Model 2 was categorized as a very slender building because the ratio of its height (H) to its width (D) = 40/10 = 4. Meanwhile, the ideal slenderness ratio to reduce building flexibility is $H/D < 2$ [23]. In order to significantly increase the stiffness of the 2A model, 2 © 2.5 × 5 m of core walls (formulas 1 to 6) were installed at the ends of the building wings in the X- and Y- axes together with 2 © 2 m shear walls towards the X-axis at the intersection of masses A and B. Before the installation of shear walls, the fundamental period (T) of model 2 = 1.942 seconds (Table 4a), and it was then decreased as many as 1.151 seconds after the installation of core walls and shear walls in model 2A (Table 4b). With the fundamental period (T) of the 2A model ≈ 1.09 seconds (T max), it means the stiffness of the model 2A already possesses the required capacity to resist strong earthquakes.

Model 2 had the shape mode, namely mode 1 = translation towards the Y- axis and dominant, mode 2 = rotation towards the Z- axis and dominant, and mode 3 = translation towards the -X axis and dominant; this means that model 2 is categorized as an irregular building, so its deformation behavior needs to be corrected. After shear walls and core walls were installed in model 2A, the deformation behavior improved and it became a regular building where mode 1 = translation towards the X-axis

and dominant, mode 2 = translation towards the Y- axis and dominant, and mode 3 = rotation towards the -Z axis and dominant.

The eccentricity ratios of models 2 and 2A = 0 (Table 5), so the potential for torsion is relatively small. The use of shear walls in model 2A prevents the formation of torsional irregularity and re-entrant corner irregularity configurations.

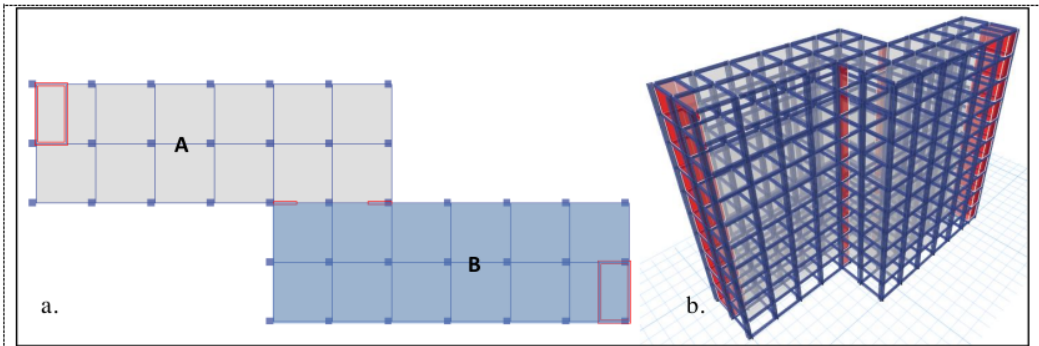

Figure 15. Model 2A (after shear walls were installed: a) the plan, b) 3D.

Table 4. Modal direction factors of Models 2 and 2A.

a). Model 2				b). Model 2A					
Mode	Period (s)	UX	UY	RZ	Mode	Period (s)	UX	UY	RZ
1	1.942	0	1	0	1	1.151	1	0	0
2	1.817	0	0	1	2	0.955	0	1	0
3	1.813	1	0	0	3	0.655	0	0	1

Table 5. Eccentricity ratios of the Models 2 and 2A.

Stories	Model 2		Model 2A	
	e_{rx}	e_{ry}	e_{rx}	e_{ry}
Storey10	0.000	0.000	0.000	0.000
Storey9	0.000	0.000	0.000	0.000
Storey8	0.000	0.000	0.000	0.000
Storey7	0.000	0.000	0.000	0.000
Storey6	0.000	0.000	0.000	0.000
Storey5	0.000	0.000	0.000	0.000
Storey4	0.000	0.000	0.000	0.000
Storey3	0.000	0.000	0.000	0.000
Storey2	0.000	0.000	0.000	0.000
Storey1	0.000	0.000	0.000	0.000

4.3. Models 3 and 3A

Model 3 needed shear walls to improve its performance, and model 3A (Figure 16) was the model where shear walls had been installed. From formulas 1 to 3, it was found that model 3 needed 4 © 4.2–5 m of shear walls.

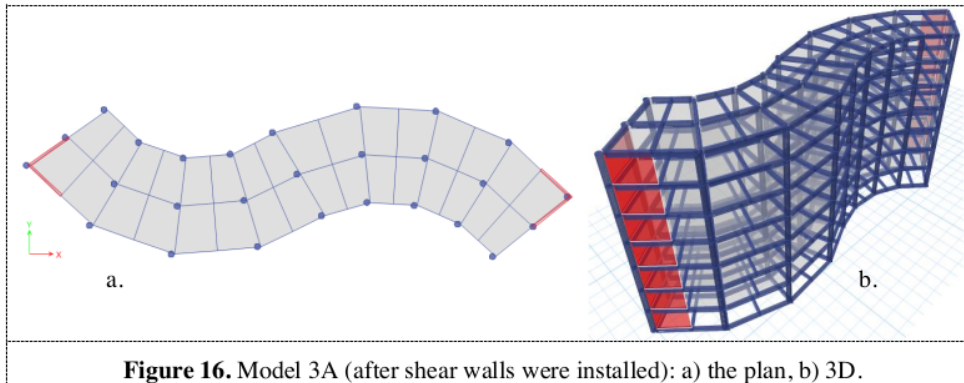

Figure 16. Model 3A (after shear walls were installed): a) the plan, b) 3D.

Table 6. Modal direction factors of Models 3 and 3A.

a). Model 3					b). Model 3A				
Mode	Period (s)	UX	UY	RZ	Mode	Period (s)	UX	UY	RZ
1	1.099	0.021	0.940	0.04	1	0.690	0.701	0.299	0
2	1.049	0.001	0.042	0.958	2	0.569	0.299	0.701	0
3	1.029	0.979	0.019	0.003	3	0.398	0	0	1

Table 7. Eccentricity ratios of Models 3 and 3A.

Stories	Model 3		Model 3A	
	e_{rx}	e_{ry}	e_{rx}	e_{ry}
Storey7	0.004	0.006	0.004	0.020
Storey6	0.003	0.006	0.004	0.023
Storey5	0.003	0.005	0.005	0.029
Storey4	0.003	0.005	0.006	0.036
Storey3	0.003	0.005	0.006	0.043
Storey2	0.003	0.004	0.005	0.048
Storey1	0.002	0.002	0.002	0.044

The fundamental period (T) the model 3 before the installation of shear walls was 1.099 seconds (Table 6a), and after shear walls installation (the model 3A), its fundamental period (T) was 0.69 seconds (Table 6b); it means it is less than T max (0.83 seconds). Installing the shear walls, thus, significantly increased the building's stiffness in overcoming potential strong earthquakes.

The mode shape of model 3 is categorized as an irregular building because mode 1 = translation, mode 2 = rotation, and mode 3 = translation (Table 6a). After shear walls installation at the ends of the building wings, the performance of the 3A model improved where modes 1 and 2 = translation, mode 3 = rotation and all of these modes were quite dominant (Table 6b).

That the entire eccentricity ratio of models 3 and 3A e_{rx} and e_{ry} is less than < 0.1 (Table 7) means that the potential for torsional irregularity configuration in model 3A is not a crucial problem for this organic-shaped building. However, the potential for the formation of non-parallel system irregularity configurations [22] in model 3A must be considered since the installation of shear walls does not simply eliminate the potential for torsion and excessive stress that can cause unexpected local damage [24].

4.4. Models 4 and 4A

Model 4 (Figure 7) had masses with different heights. The deformation behavior of model 4, actually, was still quite good, but there was translation and rotation that were not dominant enough (Table 8a). Therefore, it was necessary to install shear walls as in model 4A (Figure 17) to improve the deformation behavior. For the calculation of its shear wall mass, mass A and mass B were divided in which only mass A became the focus while mass B was not really considered because it was relatively small. Based on formulas 1 to 3 for mass A, the results showed that the shear walls were 4×5 m towards the X-axis and 6×5 m towards the Y-axis.

The fundamental period (T) of model 4 = 1.832 seconds (Table 8a) and after the shear walls were installed, its fundamental period (model 4A) = 1.151 seconds (Table 8b); hence T of model 4A ≈ 1.09 seconds (Tmax). This means the stiffness of the 4A model meets the prerequisite earthquake resistance.

Model 4 was actually categorized as a fairly regular building since mode 1 was translation, mode 2 was translation, and mode 3 was rotation, but mode 1 and mode 3 were not dominant enough (Table 8a). In this model, mode 1 translation was mixed with rotation, and Mode 3 rotation was mixed with translation. This condition indicates that the performance of the deformation behavior can still be improved. After shear walls were installed at the ends of the building's wings, on the sides of mass A, and at the intersection of mass A and mass B; the performance of the deformation behavior improved in which mode 1 translation towards the X-axis and dominant, mode 2 translation towards the Y-axis and dominant, and mode 3 rotation towards the Z-axis and dominant (Table 8b).

The potential rotation in model 4 towards X-axis was relatively small ($e_{rx} < 0.1$) but the potential rotation towards the Y-axis was categorized as medium ($0.1 < e_{ry} < 0.3$) from the stories 6 to 10 (Table 9). After the shear walls were installed in model 4A, the potential rotation towards the X-axis was kept small ($e_{rx} < 0.1$) while the eccentricity towards the Y-axis ($e_{ry} < 0.1$) on the stories 6 to 10 could be reduced so that the potential rotation was relatively small (Table 9). Therefore, the potential torsion in the vertical geometric configuration [22] with a symmetrical composition and the re-entrant corner irregularity configuration in model 4A can be controlled by the shear walls.

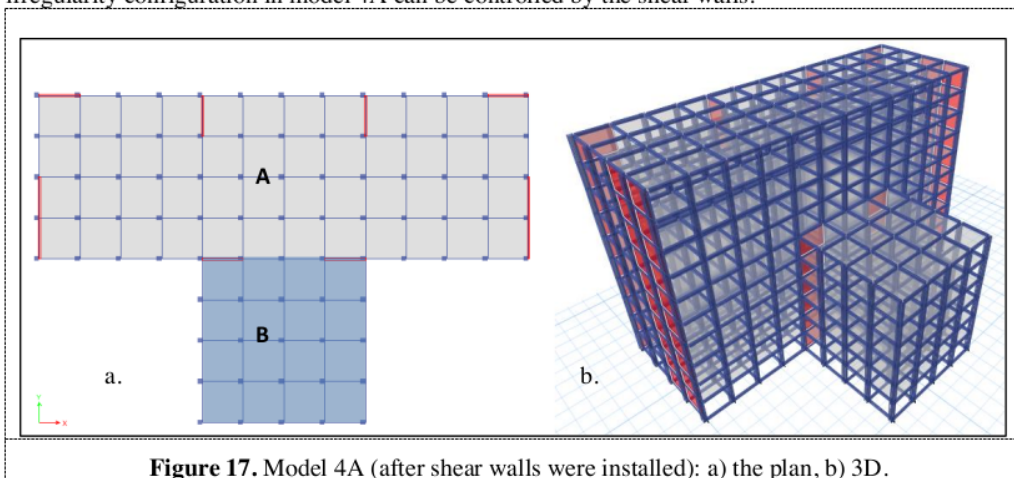

Figure 17. Model 4A (after shear walls were installed): a) the plan, b) 3D.

Table 8. Modal direction factors of Models 4 and 4A.

a). Model 4					b). Model 4A				
Mode	Period (s)	UX	UY	RZ	Mode	Period (s)	UX	UY	RZ
1	1.832	0.657	0	0.343	1	1.151	1	0	0
2	1.777	0	1	0	2	0.841	0	1	0
3	1.593	0.355	0	0.645	3	0.629	0.032	0	0.989

Table 9. Eccentricity ratios of Models 4 and 4A.

Stories	Model 4		Model 4A	
	e_{rx}	e_{ry}	e_{rx}	e_{ry}
Storey10	0	0.136	0	0.058
Storey9	0	0.160	0	0.073
Storey8	0	0.188	0	0.085
Storey7	0	0.218	0	0.094
Storey6	0	0.190	0	0.055
Storey5	0	0.076	0	0.005
Storey4	0	0.062	0	0.012
Storey3	0	0.053	0	0.027
Storey2	0	0.047	0	0.040
Storey1	0	0.044	0	0.044

4.5. Models 5 and 5A

The deformation behavior in model 5 (Figure 9) can be categorized as the regular building, but its rotation mode is not dominant enough. In order to fix this, the mass of model 5A (Figure 18a) was divided based on the height difference, but the calculation of its shear walls only focused on masses A and B while mass C was not considered because it was relatively small. With formula 1 to 3, the obtained results were 2 @ 5 m of shear walls towards the X-axis for mass A, 4 @ 5 m of shear walls towards the X-axis, and 4 @ 5 of shear walls towards the Y-axis for mass B (Figure 18).

The fundamental period (T) of model 5 = 1.562 seconds (Table 10a), and then its stiffness increased after shear walls were installed in which its fundamental period (T) = 1.039 seconds (Table 10b). This period is still below $T_{max} = 1.09$ seconds, so the stiffness of the 5A model is still in accordance with the required standard for strong earthquake resistance.

Model 5 was with mode 1 = translation towards the X-axis and dominant, mode 2 = translation towards the Y-axis and dominant, and mode 3 = rotation towards the Z-axis and less dominant (Table 10a). This model actually can be categorized as a regular building, but the weakness is that mode 3 was not dominant enough, and it was a challenge whether the deformation behavior could be corrected like the previous models. After two shear walls were installed at the ends of mass A, at the intersection of mass A and B, at wingtips of mass B building, and 4 shear walls were installed at the intersection masses B and C; the deformation behavior of the model 5A improved. This deformation behavior became mode 1 = translation towards the Y-axis and dominant, mode 2 = translation towards the X-axis and dominant, and mode 3 = rotation and quite dominant (Table 10b).

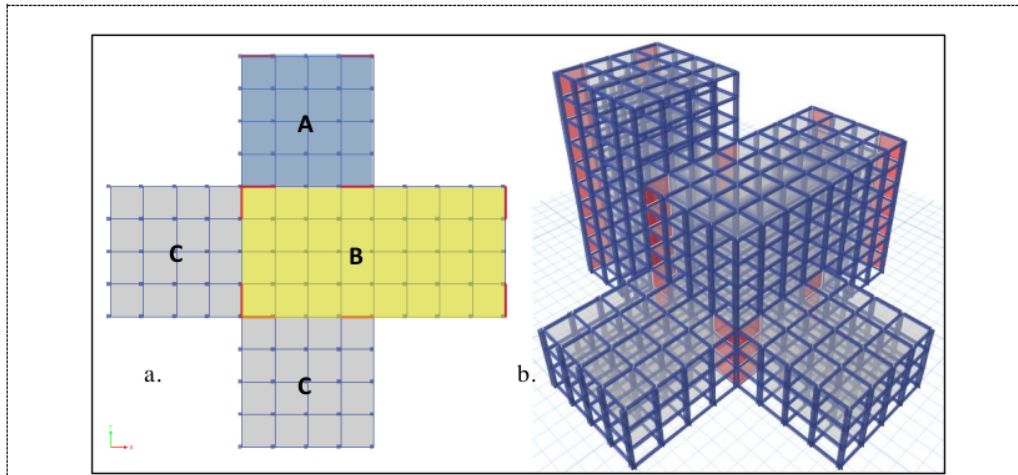

Figure 18. Model 5A (after shear walls were installed): a) The Plan, b) 3D.

Table 10. Modal direction factors of Models 5 and 5A.

a). Model 5					b). Model 5A				
Mode	Period (s)	UX	UY	RZ	Mode	Period (s)	UX	UY	RZ
1	1.562	0.814	0.019	0.167	1	1.039	0.014	0.929	0.056
2	1.385	0.008	0.989	0.003	2	0.817	0.979	0.004	0.018
3	1.019	0.359	0.053	0.588	3	0.592	0.14	0.155	0.705

Table 11. Eccentricity ratios of Models 5 and 5A.

Stories	Model 5		Model 5A	
	e_{rx}	e_{ry}	e_{rx}	e_{ry}
Storey10	0.021	0.061	0.043	0.035
Storey9	0.033	0.097	0.067	0.007
Storey8	0.056	0.168	0.125	0.054
Storey7	0.034	0.166	0.164	0.059
Storey6	0.001	0.130	0.132	0.016
Storey5	0.026	0.123	0.102	0.004
Storey4	0.058	0.135	0.045	0.016
Storey3	0.068	0.127	0.016	0.021
Storey2	0.057	0.104	0.021	0.013
Storey1	0.048	0.087	0.058	0.035

Model 5 had vertical geometric irregularity configurations because it had several masses with different heights. It can be seen in Table 11 that the vertical geometric irregularity configurations with random composition caused eccentricity towards the Y-axis direction from stories 2 to 8 in the medium category ($0.1 < e_{ry} < 0.3$), and such conditions can create significant potential torsion. It turned out that after the shear walls were installed in model 5A, the eccentricity with the medium category

($0.1 < e_{rx} < 0.3$) still occurred towards the X-axis from stories 5 to 8. This condition means that the formation of torsional irregularities in models 5 and 5A is caused by vertical geometric irregularity configurations with random compositions, and such problem is not easy to control. The installation of shear walls in the 5A model only controls the formation of the re-entrant corner irregularity configurations.

5. Conclusions

From the calculation of all formulas, guidance about shear wall requirements and the steps for shear wall installation in models 1A to 5A can be made as follows:

- The formulas 1 to 12 and steps 1 to 5 are quite accurate in calculating the areas and locations of shear walls.
- Optimum installation of shear walls in buildings can be achieved when the strength and stiffness are increased, the distribution of strength and stiffness is relatively even, the deformation behavior can be anticipated, and the eccentricity can be reduced.
- Installation of shear walls can optimally fix torsional irregularity and re-entrant corner irregularity configurations.
- Installation of shear walls in vertical geometric irregularities can only optimize building irregularity with symmetrical geometric compositions (1 or 2 axes) while building irregularity with random geometric compositions is quite difficult to control its eccentricity.
- Shear wall installation in the configuration of non-parallel system irregularity is quite difficult to achieve optimal conditions. This action can only solve problems related to strength, stiffness, deformation behavior, and eccentricity, whereas the distribution of strength and stiffness is quite difficult to control when the shape of a building is organic and random.
- If the addition of shear walls only causes an insignificant reduction of the fundamental period, consider using the combination of core walls and shear walls.
- The building's predetermined areas and core positions can be assumed as part of the structural column. After structure and modal analyses with ETABS were carried out and the building was evidently categorized as an irregular building, shear walls can be added to fix its irregularity by applying those 12 formulas and 5 steps.

Acknowledgments

This research was fully supported by Sriwijaya University PNPB funding through the S5 NSTEM scheme. Researchers would like to express their gratitude to Sriwijaya University that made this important research feasible and effective.

References

- [1] Banginwar R S, Vyawahare M R and Modani P O 2012 Effect of plans configurations on the seismic behavior of the structure by response spectrum method *Int. J. Eng. Res. Appl.* **2** 1439–43
- [2] Tarigan J 2007 *Kajian Struktur Bangunan Di Kota Medan Terhadap Gaya Gempa Di Masa Yang Akan Datang* (Indonesian)
- [3] Ravikumar, Narayan K S B, B V S and Reddy D V 2012 Effect of Irregular Configurations on Seismic Vulnerability of RC Buildings *Architecture Research* **2** 20-26
- [4] Kewalramani M A and Syed Z I 2018 Seismic Analysis of Torsional Irregularity in Multi-Storey Symmetric and Asymmetric Buildings *Eurasian J. Anal. Chem.* **13** 3
- [5] Banerjee R and Srivastava J B 2020 Defining Optimum Location of Shear Wall in an Irregular Building by Considering Torsion *Int. J. Eng. Adv. Technol.* **9** 4 2247–51
- [6] Powale S A and Pathak N J 2019 A comparative study of torsional effect of earthquake on “L” and “S” shaped high rise buildings *Int. J. Sci. Technol. Res.* **8** 8 1355–9
- [7] Botis M F and Cerbu C 2020 A Method for Reducing of the Overall Torsion for Reinforced Concrete Multi-Storey Irregular Structures *Appl. Sci.* **10** (16) 5555

- [8] Basu D and Jain S K 2007 Alternative method to locate center of rigidity in asymmetric buildings *Earthq. Eng. Struct. Dyn.* **36** (7) 965–73
- [9] Botiş M F, Cerbu C and Shi H 2018 Study on the reduction of the general / overall torsion on multi – story, rectangular, reinforced concrete structures *IOP Conf. Ser. Mater. Sci. Eng.* **399** 12005
- [10] Zhang Y and Mueller C 2017 Shear wall layout optimization for conceptual design of tall buildings *Eng Struct* **140** 225–40
- [11] Allen M P and Tildesley D J 2017 *Computer simulation of liquids* (England: Oxford University Press)
- [12] Nasution S 1995 *Metode research (penelitian ilmiah): usul tesis, desain penelitian, hipotesis, validitas, sampling, populasi, observasi, wawancara, angket* (Jakarta: Bumi Aksara)
- [13] Budiono B and Supriatna L 2011 *Studi Komparasi Desain Bangunan Tahan Gempa Dengan Menggunakan SNI 03-1726-2002 dan RSNI 03-1726-2012* (Bandung: Penerbit ITB)
- [14] Murty C V R, Goswami R, Vijayanarayanan A R and Mehta V V 2012 *Some Concepts in Earthquake Behavior of Buildings* (Gujarat: Gujarat State Disaster Management Authority Government of Gujarat)
- [15] Tjokrodiluljo K 1997 *Teknik Gempa* (Yogyakarta: Penerbit Nafiri)
- [16] Teddy L, Hardiman G, Nuroji and Tudjono S 2018 Simplified Vulnerability Analysis (SVA) Preliminary Design of the Frame Structure in the Architectural Design Process *Indian J. Sci. Technol.* **11** (May) 1–13
- [17] Ersoy U 2013 A Simple Approach for Preliminary Design of Reinforced Concrete Structures to be Built in Seismic Regions *Tenik Dergi* **24** (4) 6559–74
- [18] Vithal G U 2017 Effect of Shear Wall on Sismic Behavior of Unsymmetrical Reinforced Concrete Structure *Int. J. Res. Sci. Innov.* **IV** (X) 61–81
- [19] Ali S E and Aquil M M U 2014 Study of Strength of RC Shear Wall at Different Location on Multi-Storied Residential Building *J. Eng. Res. Appl.* **4** (9) 134–41
- [20] Duggal S K 2007 *Earthquake resistant design of structures*. Oxford university press New Delhi 2007
- [21] Fares A M 2019 The Effect of Shear Wall Positions on the Seismic Response of Frame-Wall Structures *Int. J. Civ. Environ. Eng.* **13** (3) 190–4
- [22] FEMA 2007 *NEHRP Recommended Provisions for New Buildings and Other Structures: Training and Instructional Materials-FEMA 451B* (Washington DC: Federal Emergency Management Agency)
- [23] Madutujuh N 2020 *Perencanaan Gedung Bertingkat dengan Program SANSPRO* (Jakarta)
- [24] Arnold C 2006 *Seismic Issues In Architectural Design. In: Designing For Earthquakes A Manual For Architects - FEMA 454* (California: Engineering Research Institute)

study of shear wall

ORIGINALITY REPORT

8%

SIMILARITY INDEX

PRIMARY SOURCES

- | | | |
|---|---|-----------------|
| 1 | dspace.uevora.pt
Internet | 85 words — 2% |
| 2 | dspace.brunel.ac.uk
Internet | 50 words — 1% |
| 3 | Deng, Peng, Xin Li, Wei Dong, and Lei Tai. "Seismic Analysis of L-Shaped Irregular Plane Frame Structure with Viscous Dampers", <i>Applied Mechanics and Materials</i> , 2014.
Crossref | 47 words — 1% |
| 4 | Qienyuan Zhou. "Light scattering and form birefringence of parallel cylindrical arrays that represent cellular organelles of the retinal nerve fiber layer", <i>Applied Optics</i> , 04/01/1997
Crossref | 31 words — 1% |
| 5 | journal.unwira.ac.id
Internet | 30 words — 1% |
| 6 | "Advances in Geotechnics and Structural Engineering", Springer Science and Business Media LLC, 2021
Crossref | 25 words — < 1% |
| 7 | Aldurayheem, Abdulhameed Abdullah. "The Influence of First Language Aptitude and Print Exposure (Arabic) on Foreign Language Learning Performance | 25 words — < 1% |

(English) and the Effectiveness of the General Aptitude Test in Saudi Arabia.", Liverpool John Moores University (United Kingdom), 2021

ProQuest

8 Hamid Dehnavipour, Hossein Meshki, Hosein Naderpour. "Torsion-based layout optimization of shear walls using multi-objective water cycle algorithm", Advances in Structural Engineering, 2021

24 words — < 1%

Crossref

9 Daud Rahmat Wiyono, Roi Milyardi, Cindrawaty Lesmana. "Distribution of Story Shear and Reinforcement in Dual System", IOP Conference Series: Materials Science and Engineering, 2020

17 words — < 1%

Crossref

10 ejournal2.undip.ac.id

Internet

16 words — < 1%

11 Xinzheng Lu, Hong Guan. "Earthquake Disaster Simulation of Civil Infrastructures", Springer Science and Business Media LLC, 2021

14 words — < 1%

Crossref

12 Q.S. Li. "Free Vibration Analysis of Flexural-Shear Plates Under the Action of Axial Forces", Advances in Structural Engineering, 2016

12 words — < 1%

Crossref

13 apps.dtic.mil

Internet

11 words — < 1%

14 "Effective Positioning of Shear Wall in G+5 Storey Building on Sloping Ground", International Journal of Engineering and Advanced Technology, 2019

8 words — < 1%

Crossref

15 "Seismic Behaviour and Design of Irregular and Complex Civil Structures III", Springer Science and Business Media LLC, 2020 8 words — < 1%
Crossref

16 Asgarian, Amin. "New Methodology to Generate Floor Design Spectra (FDS) Directly from Uniform Hazard Spectra (UHS) for Seismic Assessment of Non-structural Components (NSCS) of Buildings.", McGill University (Canada), 2021 8 words — < 1%
ProQuest

17 Humam Al-Jumaili, Osamah Mahmood, Mohammed Oleiwi, Waleed Jamal Hamid. "Investigating the Effect of Seismic Loads on Multi-Story Buildings with Different Shear Wall Configurations and Building's Ratios", International Review of Civil Engineering (IRECE), 2020 8 words — < 1%
Crossref

18 Livian Teddy, Gagoek Hardiman, Nuroji, Sri Tudjono. "The effect of earthquake on architecture geometry with non-parallel system irregularity configuration", IOP Conference Series: Earth and Environmental Science, 2017 8 words — < 1%
Crossref

19 cgtech.com 8 words — < 1%
Internet

20 id.scribd.com 8 words — < 1%
Internet

21 www.mdpi.com 8 words — < 1%
Internet

22 Livian Teddy, Johannes Adiyanto, Husnul Hidayat. "Identifying geometric configuration of 7 words — < 1%

earthquake-resistant buildings", ARTEKS : Jurnal Teknik
Arsitektur, 2021

Crossref

23 Ahmet Tuken, Nadeem A. Siddiqui. "SBC-based assessment of shear wall quantity in moment resisting frame buildings", KSCE Journal of Civil Engineering, 2014 6 words — < 1%

Crossref

24 Haopeng Lou, Boqing Gao, Fengling Jin, Yinyuan Wan, Yaxing Wang. "Shear wall layout optimization strategy for high-rise buildings based on conceptual design and data-driven tabu search", Computers & Structures, 2021 6 words — < 1%

Crossref

EXCLUDE QUOTES OFF

EXCLUDE MATCHES OFF

EXCLUDE BIBLIOGRAPHY ON