

ELECTRONIC ARM FOR VESA-2 REPLACING THE HUMAN HAND ROLE IN KEMPLANG ROASTING PROCESS IN PALEMBANG – INDONESIA

by Darmawi Darmawi

Submission date: 19-Oct-2022 07:03AM (UTC+0700)

Submission ID: 1929136805

File name: ectronic_Arm_for_VESA-2_Replacing_The_Human_Hand_Role_in.....pdf (2.55M)

Word count: 2099

Character count: 11294



ISSN: 2230-9926

Available online at <http://www.journalijdr.com>

IJDR

International Journal of Development Research

Vol. 12, Issue, 09, pp. 59296-59299, September, 2022

<https://doi.org/10.37118/ijdr.25439.09.2022>



RESEARCH ARTICLE

OPEN ACCESS

ELECTRONIC ARM FOR VESA-2 REPLACING THE HUMAN HAND ROLE IN KEMPLANG ROASTING PROCESS IN PALEMBANG – INDONESIA

*Darmawi, Riman Sipahutar, Irwin Bizzy and Jimmy D Nasution

Mechanical Engineering Dept. Lecturers of Engineering Faculty of Universitas Sriwijaya, Indonesia

ARTICLE INFO

Article History:

Received 20th August, 2022
Received in revised form
26th August, 2022
Accepted 13th September, 2022
Published online 30th September, 2022

Key Words:

Roasting, Vesa-2, Kemplang, Electronic arm.

*Corresponding author: Darmawi,

ABSTRACT

A series of attempt is conducted to minimized the role of human hand in kemplangroasting, the traditional snack of Palembang - South Sumatra, Indonesia. Traditionally, the roasting is perform manually on an open charcoal fire. The negative effect on human health has become the main attentionin this matter regarding the spread of emissions gases, heat emitted and particulates generated. An equipment named PenghematEnergiVertikal (Vertical Energy Saver) or abbreviated as VESA-2 is already developed and improved. VESA-2 is an equipment made to accommodated the heat emitted, the gas and particulates generated from the charcoal stove to be streamed to a place that is safe from human breathand environment. The use of speed controller and switch relay to create reverse rotationand has already successfully imitate the human hand movement to roast kemplang. Geared DC motor is used to get the low output RPM and to facilitate the simple transmission system.

Copyright © 2022, Ana Paula do Nascimento Rocha et al. This is an open access article distributed under the Creative Commons Attribution License, which permits unrestricted use, distribution, and reproduction in any medium, provided the original work is properly cited.

Citation: Darmawi, Riman Sipahutar, Irwin Bizzy and Jimmy D Nasution, 2022. "Electronic arm for vesa-2 replacing the human hand role in kemplang roasting process in Palembang – Indonesia", *International Journal of Development Research*, 12, (09), 59296-59299.

INTRODUCTION

The attention to kemplang roasting process has started from the year 2014 in Palembang [1]. Kemplang is roastedon an open charcoal fire as shown in figure 1a,b,c and d. The main problem of traditional open charcoal fire is how to managethe heat emitted, the smoke generated, the exhaust gases and particulates produced, to be accommodated to a place that is safe to human breath and safe to the surrounding environment. The answer has already given by an equipment names VESA-2, i.e. an equipment made to accommodate the heat, the gas, and the particulates generated from the charcoal fire to be distributed to a place that is safe to the people and to thekemplang roasters.VESA-2 is an equipment that has already have patent right created and developed for a better and heathier roasting process in Palembang.

Method of Creating the Electronic Arm of Vesa-2: In order to replace the hand role of human in roasting the kemplang, we shouldobserve the way kemplang roasted by mothers who use the kemplang as a matter of daily business.Kemplang is roasted by a back and forth motion. One kemplang roasting is completed in 40 seconds to 70 seconds depending on the experience of the mothers who roast it. The roasting movement is imitated by the electronic armas wanted to create.

The first consideration of creating the Electronic Arm is mechanically. It is by modifying the revolution movement of electric motor became the reversal movement by a series of gears installed and linked to the output shaft of motor. This idea looks feasible technologically, but not feasible to constructed. Mainly regarding the weight of construction, the space to reserved, the cost to manufactured and the time to created. So, a set of gears arranged to reduce the RPM and reversed the rotation of motor is not economical and not feasible to realized. The choice is then focused on geared DC motor. This kind of power generation is suitable for imitating the roasting movement. Voltage of 12V – 24V, low speed, high torque, low powerconsumption, low noise, simple machine structure, easy maintenance and long service life. In order to make VESA-2 a safer equipment, the VESA-2 should completed with an electric tool that can imitate the human hands roasting movements. This tool is we are focusing on in this discussion. We call this tool is an Electronic Arm.To imitate the mothershand movements in kemplangroasting process, at the first time we should learn and understand how to process. The movements of mothers hand when roastingkemplang is reversionary movement i.e. forward and backward movements. The technology of doing this is already available, i.e.small geared motor with controller as indicated in figure 1a and Figure 1b. Basically, the speed controller, is a device which combine the pulse width modulation (PWM) and relay. Relay is used to connect and to break the electric circuit current. The electromagnet existed in relay will actuate the switch, so the electric of small power can distribute the electric power at higher voltage. In case of motor controller, relay is

used to reverse the direction of motor rotation [6]. Pulse Width Modulation (PWM) is a digital technology that uses the amount of power delivered to a device that can be changed by modifying the width of signal pulse at fixed amplitude and frequency. It generates analogue signals by using a digital source. A PWM signal is basically a square wave which is switched between on and off state.



(a) (b)



(c) (d)

Figure 1a, 1b, 1c and 1d show mothers roasting kemplang on an open charcoal fire. They use a long stick to prevent heat and wear a thick and long sleeve to protect their body and protect their breath too [2]

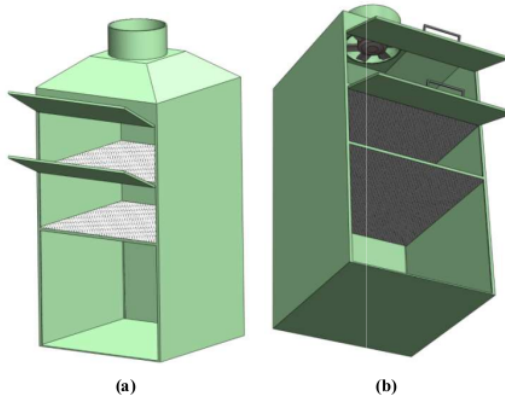

(a) (b)

Figure 2a and 2b. Schematic VESA that certified by patent right in 2019 before being developed [3]

A dimmer is a device connected to an electric instrument and used to lower the power supplied to the instrument by changing the voltage wave form, it lower the power supplied. It lower the brightness of light, it lower the revolution of fan blades. [7] The turning switch controller and dimmer is combined on a single board microcontroller, which operating voltage: DC 10V-60V; Output Current: 0 to 20A; Frequency: 25KHz; Continuous power: Max 1200W

Speed range: Motor zero speed to maximum motor speed. The output current is directly generate a geared DC motor. The net output rpm of motor is ranging from 60 to 350 rpm, a suitable revolution for kemplang roasting process. All of the components are available in the market and ready to assembled. Many electric motor is available in the market. Commonly of high RPM ranging from 9000 RPM to 14000 RPM.

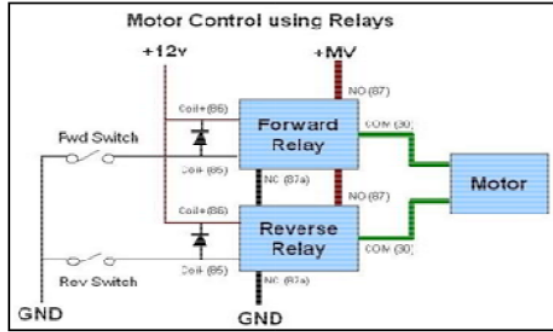

Figure 3a. Motor controller with forward and reverse relay switch [4]

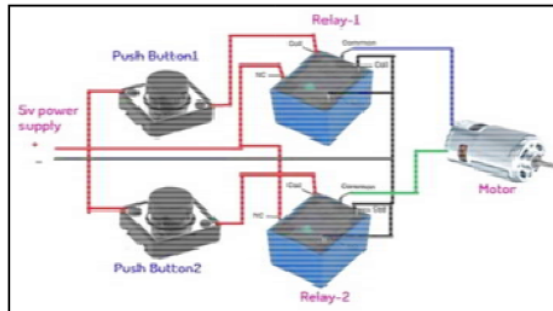

Figure 3b. Motor controller with push button relay [5]

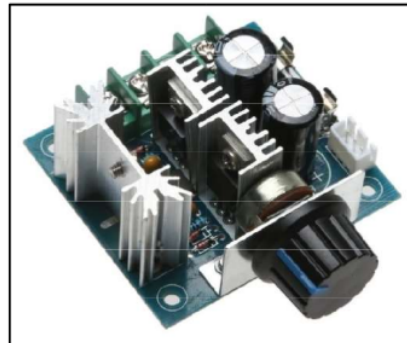

Figure 4. DC Motor Speed Governor PWM Controller DC 12V 24V 30V 40V 13KHZ [8]

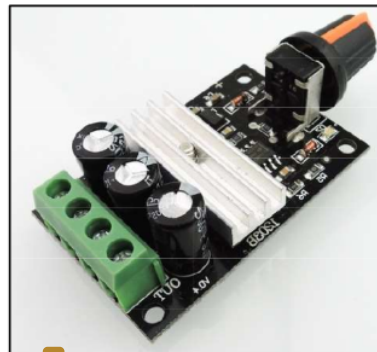

Figure 5. QQ-2: PWM DC 6V – 24V, 3A Motor Speed Control Switch Controller [9]

This rotation much difficult to control by the simple reduction gears. It needs some stages of gear pair that make the constructions not simple. Geared DC motor is applied to facilitate the low RPM and high torque. The high torque is required to hold the roasting arm and to turn it back and forth. Geared DC motor is preferable in order to avoid electrical short and for the safe of operation.

RESULTS

Electronic ARM: The electronic arm is consist of four main parts, controller, DC motor, Transmission system and roasting arm as shown in Figure 6.

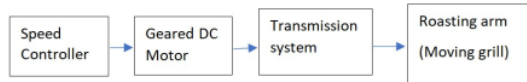

Figure 6. The electronic arm systems is consist of speed controller, Geared DC Motor, Transmission system and Roasting arm

Speed Controller

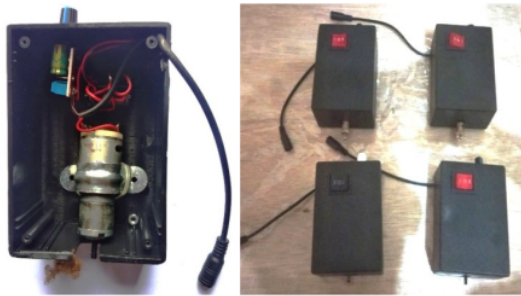

Figure 7. Speed controller and geared DC motor is packed in a fix box



Figure 8. Speed controller and switch reverse rotation is packed in separated box to the geared DC motor to enable it to operate at a distance

Roasting ARM: Roasting arm is a part of electronic arm system, a place for putting the eight kemplangs inside at once, entirely made of stainless steel. Roasting arm is a hollow circular pipe with four roasting cage crossing the hollow circular pipe. Roasting cages are made of stainless grill net where the kemplangs can put in when the process started and put out when the process completed.

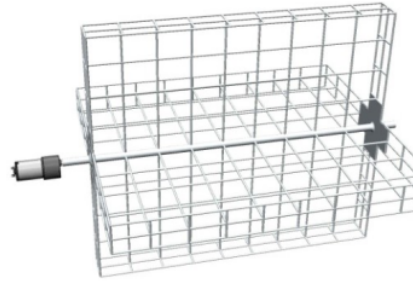

Figure 9. Roasting arm with four roasting cages crossing the shaft

This hollow circular pipe is directly coupled to the DC geared motor and supported at ends at bothsides of VESA-2. Flexible coupling is applied at left end and roll supported at both ends. A tension spring is permanently attached at right end to push the roasting arm shaft to stay connected to the left flexible coupling.

VESA-2EA: VESA-2EA is a VESA-2 that already completed with the Electronic Arm. The final form of VESA-2EA is schematically shown in figure 10. A lift window is existed on top to put in and to put out the not yet roasting kemplang. The main door is a half side of the body, where the roasting arm and the transmission system is attached. A blowing fan is attached at below, to inhale the air from the vicinity and flowing it to the top of VESA-2EA. This air is passed through the charcoal fire and flowing to the top of VESA-2EA and extracted to the atmosphere. Partially, a part of this hot air passing the upper cabin where the not yet roasting kemplang is put in. At this side, the hot from air is used to heat and drying the kemplang to make it ready to roasted.

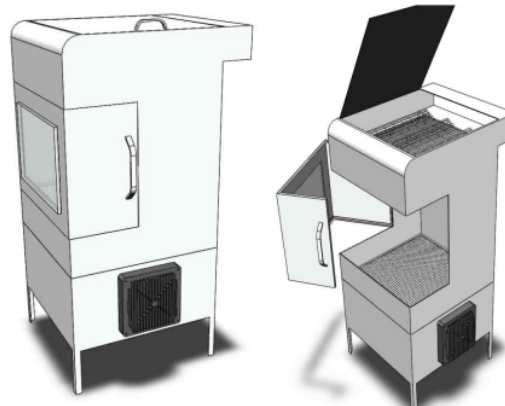

Figure 10. Schematic figure of final VESA-2EA. [10]

DISCUSSION

From the results found above, we could say that the evolving of technology able to support and facilitate the comfort of human daily life. Electronic arm at VESA-2 is not a finding, but a creativity of knowledge and technology innovation for the sake of health and social welfare. Many things could do with recent technology, but needs capacity to match it to the problems faced by the people. The technology evolving too fast in recent years, it tend to left the people to adapt. [11]

CONCLUSION

1. PWM speed controller and switch relay is a suitable combination to imitate the back and forth movement as done in roasting kemplang.

2. Geared DC motor is used to get the low RPM and high torque motor and facilitate the simple transmission system.
3. The new form of kemplang has already created in order to match with the roasting arm developed in VESA-2.

ACKNOWLEDGEMENT

Many thanks is addressed to the Engineering Faculty of Universitas Sriwijaya, the institution that always push us to creative and produce innovations for the community purposes.

REFERENCES

- Darmawi, Riman Sipahutar, and Jimmy D Nasution, "APLIKASI RANCANG BANGUN ALAT PEMANGGANG KEMPLANG PALEMBANG YANG HEMAT ENERGI, SEHAT DAN HYGIENIS UNTUK USAHA KECIL DI KENTEN PALEMBANG," Palembang, 2014. [Online]. Available: https://docs.google.com/document/d/1-rMqj_QYJBYnqgHdiWbGR2sur_yh7iOW/edit
- M. Dr. Ir.Darmawi, M. Prof.Dr. Riman Sipahutar, ST., M. Qomarul Hadi, ST., and M. Ellyanie, ST., "Alat penghemat energi vertikal untuk pemanggang kemplang desa Tanjung Gelam Kecamatan Indralaya Kabupaten Ogan Ilir," 2020. [Online]. Available: ALAT PENGHEMAT ENERGI VERTIKAL %0AUNTUK PEMANGGANG KEMPLANG DESA TANJUNG GELAM%0AKECAMATAN INDRALAYA %0AKABUPATEN OGAN ILIR%0A%0A
- D. Darmawi, "Evaluasi Kualitatif Alat Penghemat Energi Vertikal Bagi Usaha Kecil Mikro Di Desa Tanjung Gelam Kabupaten Ogan Komering Ilir," 2020, no. November, p. 4.
- Tri-Pact News Service, "R/C Combat Vehicles Speed Controls," *Open publication*, 2021. <https://www.rctankcombat.com/articles/speed-control/> (accessed Jul. 30, 2022).
- FRIENDTECHBD, "Motor forward reverse control circuit diagram," *Open publication*, 2021. <https://friendtechbd.com/motor-forward-reverse-control-circuit-diagram/> (accessed Jul. 30, 2022).
- Yahoo.com, "6 Fungsi Relay pada Listrik, Ketahui Jenis-jenis dan Cara Kerjanya," *web news*, 2021. <https://id.berita.yahoo.com/6-fungsi-relay-pada-listrik-143032980.html> (accessed Jul. 26, 2022).
- Wikipedia, "Dimmer," *Online page*, 2022. <https://en.wikipedia.org/wiki/Dimmer> (accessed Jul. 27, 2022).
- <https://www.sparkpcb.com/development/12v-40v-10a-pwm-dc-motor-speed-control-board.html>DC Motor Speed Governor PWM Controller DC 12V 24V 30V 40V 13KHZ Auto ...
- [https://electrobist.com/product/pwm-dc-6v-12v-24v-28v-3a-motor-speed-control-switch-controller/PWM DC 6V 12V 24V 28V 3A Motor Speed Control Switch Controller](https://electrobist.com/product/pwm-dc-6v-12v-24v-28v-3a-motor-speed-control-switch-controller/PWM%20DC%206V%2012V%2024V%2028V%203A%20Motor%20Speed%20Control%20Switch%20Controller)
- Jimmy D Nasution, Documented Engineering Drawing for Vesa-2, 2022 (accessed Sept 23,2022). <https://drive.google.com/drive/folders/1a4veYc_9EYv4BuX0-Akw1JqR_1l3-BsQ>
- Chris Hooper, Is technology evolving faster than our ability to adapt, *web page*, June 2, 2015. (accessed Sept.20,2022). <https://www.linkedin.com/pulse/technology-evolving-faster-than-our-ability-adapt-chris-hooper>

ELECTRONIC ARM FOR VESA-2 REPLACING THE HUMAN HAND ROLE IN KEMPLANG ROASTING PROCESS IN PALEMBANG - INDONESIA

ORIGINALITY REPORT

10%

SIMILARITY INDEX

10%

INTERNET SOURCES

2%

PUBLICATIONS

5%

STUDENT PAPERS

PRIMARY SOURCES

1	journalijdr.com Internet Source	4%
2	www.inputcomponents.com Internet Source	1%
3	www.coursehero.com Internet Source	1%
4	stepacademic.net Internet Source	1%
5	me.iitgn.ac.in Internet Source	1%
6	picclick.com Internet Source	1%

Exclude quotes On

Exclude bibliography On

Exclude matches < 1%