



economies

CITESCORE
2.7

Covered in:
ESCI



The Influence of an Export Manager on Olive Oil Export Marketing Policies

Volume 10 • Issue 7 | July 2022



mdpi.com/journal/economies
ISSN 2227-7099

[Sign In / Sign Up \(/user/login\)](#)[Submit \(https://susy.mdpi.com/user/manuscripts/upload?journal=economies\)](https://susy.mdpi.com/user/manuscripts/upload?journal=economies)

Search for Articles:

Advanced Search

[Journals \(/about/journals\)](#) / [Economies \(/journal/economies\)](#) / [Editorial Board \(/journal/economies/editors\)](#)**economies**[\(/journal/economies\)](#)

Tracked for
Impact
Factor



CITESCORE

2.7

[Submit to *Economies* \(https://susy.mdpi.com/user/manuscripts/upload?journal=economies\)](https://susy.mdpi.com/user/manuscripts/upload?journal=economies) [\(https://www.scopus.com/sourceid/21100902009\)](https://www.scopus.com/sourceid/21100902009)[Review for *Economies* \(https://susy.mdpi.com/volunteer/journals/review\)](https://susy.mdpi.com/volunteer/journals/review)

Journal Menu

► Journal Menu

- [Economies Home \(/journal/economies\)](#)
- [Aims & Scope \(/journal/economies/about\)](#)
- [Editorial Board \(/journal/economies/editors\)](#)
- [Reviewer Board \(/journal/economies/submission_reviewers\)](#)
- [Instructions for Authors \(/journal/economies/instructions\)](#)
- [Special Issues \(/journal/economies/special_issues\)](#)
- [Sections \(/journal/economies/sections\)](#)
- [Article Processing Charge \(/journal/economies/apc\)](#)
- [Indexing & Archiving \(/journal/economies/indexing\)](#)
- [Most Cited & Viewed \(/journal/economies/most_cited\)](#)
- [Journal Statistics \(/journal/economies/stats\)](#)
- [Journal History \(/journal/economies/history\)](#)
- [Editorial Office \(/journal/economies/editorial_office\)](#)

volume

issue

Go

> **Forthcoming issue** (/2227-7099/10/9)

> **Current issue** (/2227-7099/10/8)

Vol. 10 (2022) (/2227-7099/10)

Vol. 9 (2021) (/2227-7099/9)

Vol. 8 (2020) (/2227-7099/8)

Vol. 7 (2019) (/2227-7099/7)

Vol. 6 (2018) (/2227-7099/6)

Vol. 5 (2017) (/2227-7099/5)

Vol. 4 (2016) (/2227-7099/4)

Vol. 3 (2015) (/2227-7099/3)

Vol. 2 (2014) (/2227-7099/2)

Vol. 1 (2013) (/2227-7099/1)

Preprints

READ,
SHARE &
COMMENT
ON THE
LATEST
RESEARCH
ON
COVID-19

MDPI

Editorial Board

• **Editorial Board**

• **Macroeconomics, Monetary Economics, and Financial Markets Section**

(/journal/economies/sectioneditors/macroeconomics_monetary_economics_financial_markets)



Editors (3)

Prof. Dr. Ralf Fendel

Website (<https://www.whu.edu/en/faculty-research/economics-group/monetary-economics/team/>)

SciProfiles (<https://sciprofiles.com/profile/93004>)

Editor-in-Chief

WHU - Otto Beisheim School of Management, Burgplatz 2, 56179 Vallendar, Germany

Interests: open economy macroeconomics; monetary theory and policy; international finance; European integration; growth and development

Special Issues, Collections and Topics in MDPI journals



Prof. Dr. Joachim Wagner

Website (<https://www.leuphana.de/institute/ivwl/personen/joachim-wagner.html>)

Associate Editor

Institute of Economics, Leuphana Universität Lüneburg, Lüneburg, Germany

Interests: entrepreneurial marketing; business development; entrepreneurship education

Special Issues, Collections and Topics in MDPI journals



Prof. Dr. Robert Czudaj *

Website (<https://tu-freiberg.de/fakult6/avwl-makrooekonomik/team/professor>)

SciProfiles (<https://sciprofiles.com/profile/426293>)

Section Editor-in-Chief

Chair for Economics, in particular (Monetary) Macroeconomics Department of Economics, Technical University of Freiberg, Schloßplatz 1, D-09599 Freiberg, Germany

Interests: applied econometrics; monetary economics, macroeconomics; time series analysis; financial econometrics; financial markets; exchange rates

* Section: Macroeconomics, Monetary Economics, and Financial Markets

Special Issues, Collections and Topics in MDPI journals

Editorial Board Members (64)

Filter Editorial Board Members

Filter

Prof. Dr. Frank W. Agbola

Website (<http://www.newcastle.edu.au/profile/frank-agbola>) **SciProfiles** (<https://sciprofiles.com/profile/570954>)



Newcastle Business School, University of Newcastle, Callaghan, NSW 2308, Australia

Interests: applied econometrics; development economics; agricultural economics; international economics; financial economics; tourism economics and SMEs

Special Issues, Collections and Topics in MDPI journals

Special Issue in **Economies: Economic Development in Africa**
([/journal/economies/special_issues/Economic_Development_Africa](https://journal/economies/special_issues/Economic_Development_Africa)).

Prof. Dr. Corrado Andini

 [\(/toggle desktop layout cookie\)](#)  

Website (<https://www.iza.org/person/3407/corrado-andini>)

Department of Management and Economics, University of Madeira, Campus da Penteada, 9000-390 Funchal, Portugal

Interests: labor economics; macroeconomics; industrial organization

Special Issues, Collections and Topics in MDPI journals

Special Issue in **Economies: Labor and Development** ([/journal/economies/special_issues/labor_develop](https://journal/economies/special_issues/labor_develop))



Prof. Dr. Sajid Anwar

Website (<https://www.usc.edu.au/staff/professor-sajid-anwar#research>)

SciProfiles (<https://sciprofiles.com/profile/369135>)

School of Business, University of the Sunshine Coast, Sippy Downs, QLD 4556, Australia

Interests: international finance; international economics; international business

Special Issues, Collections and Topics in MDPI journals

Special Issue in **Sustainability: Services Sector Trade and Investment**

([/journal/sustainability/special_issues/Services_Sector](https://journal/sustainability/special_issues/Services_Sector)).

Special Issue in **Sustainability: Preferential Trade Agreements and Global Value Chains**

([/journal/sustainability/special_issues/Preferential_Trade_Agreements](https://journal/sustainability/special_issues/Preferential_Trade_Agreements)).

Special Issue in **Sustainability: Sustainable Business Finance, Economic Development and Entrepreneurship under Uncertainty**

([/journal/sustainability/special_issues/Business_Finance_Economic_Development_Entrepreneurship_Uncertainty](https://journal/sustainability/special_issues/Business_Finance_Economic_Development_Entrepreneurship_Uncertainty)).

Special Issue in **Economies: Recent Topics in Economic Research – Feature Papers for Celebrating the 10th Anniversary of Economies** ([/journal/economies/special_issues/10th_Anniversary_Economies](https://journal/economies/special_issues/10th_Anniversary_Economies)).



Prof. Dr. Andrea Appolloni

Website (<https://economia.uniroma2.it/faculty/164/appolloni-andrea>) **SciProfiles** (<https://sciprofiles.com/profile/17166>)

1. Department of Management and Law, University of Rome Tor Vergata, 00133 Rome, Italy

2. School of Management, Cranfield University, Bedford MK43 0AL, UK

3. Institute for Research on Innovation and Services for Development (IRISS), CNR – National Research Council, 80134 Naples, Italy

Interests: supply chain management; sourcing & procurement in the public and private sector; e-procurement; sustainable and green procurement/sourcing; sustainable global sourcing; sustainable development and corporate social responsibility

Special Issues, Collections and Topics in MDPI journals

Special Issue in **Sustainability: Role of Third- and Fourth-Party Logistics Providers to Support Sustainable Development Goals in Developing Countries**

([/journal/sustainability/special_issues/Third_Fourth_Party_Logistics_Providers_Support_Sustainable_Development_Goals](https://journal/sustainability/special_issues/Third_Fourth_Party_Logistics_Providers_Support_Sustainable_Development_Goals))

Special Issue in **Sustainability: The Territorial Sustainability Approach in the European and International Framework**

([/journal/sustainability/special_issues/TSA](https://journal/sustainability/special_issues/TSA)).

Prof. Dr. Roberta Arbolino

Website (http://docenti2.unior.it/index2.php?user_id=rarbolino&content_id_start=1)

SciProfiles (<https://sciprofiles.com/profile/263555>)

Department of Human and Social Sciences, University of Naples “L’Orientale”, L.go San Giovanni Maggiore 30, 80134 Naples, Italy

Interests: political economy; development economics; regional structural policy; industrial policy; growth and development; sustainable development



Prof. Dr. Dimitrios Asteriou

Website (<https://www.brookes.ac.uk/templates/pages/staff.aspx?uid=p0078108>)

Department of Accounting, Finance and Economics, Oxford Brookes University, Headington Campus, Clerici Building, Oxford OX3 0BO, UK

Interests: economic growth; energy economics; financial markets

Prof. Dr. Joydeep Bhattacharya

Website (<https://www.econ.iastate.edu/people/joydeep-bhattacharya>) **SciProfiles** (<https://sciprofiles.com/profile/264543>)

Economics Department, Iowa State University, Ames, IA 50011, USA

Interests: macroeconomics; macro-development; social security; income inequality; fertility; diseases; demographic transition

Special Issues, Collections and Topics in MDPI journals

Special Issue in ***Economies: Selected Papers from the International Conference on Sustainable Development 2017, September 18-20, 2017 New York, USA*** (/journal/economies/special_issues/ICSD2017)

September 18-20, 2017 New York, USA (/journal/economies/special_issues/ICSD2017)

Prof. Dr. Nauro F. Campos

Website (<https://sites.google.com/site/naurofcampos/>)

Department of Economics, Brunel University London, Uxbridge UB8 3PH, UK

Interests: European integration; political instability; financial development



Prof. Dr. Francesco Caracciolo

Website (<https://endless.agecon.unina.it/prof-francesco-caracciolo/>) **SciProfiles** (<https://sciprofiles.com/profile/297747>)

Department of Agricultural Sciences, University of Naples Federico II, 80055 Naples, Italy

Interests: development economics; food economics; ecosystem services; rural development; sustainable consumption

Special Issues, Collections and Topics in MDPI journals

Topical Collection in ***Sustainability: Designing More Diverse and Resilient Food Systems for the Future***

(/journal/sustainability/special_issues/Resilient_Food_Systems)

Special Issue in ***Sustainability: Climate Change and Wine: New Frontiers toward Sustainable Winemaking***

(/journal/sustainability/special_issues/Climate_Change_Wine)

Special Issue in ***Agriculture: Developing the Evidence Base for Rural Development Policies and Interventions to Address Novel and Emerging Societal Problems***

(/journal/agriculture/special_issues/rural_development_policies)



Prof. Dr. Richard J. Cebula

Website (https://scholar.google.com/citations?hl=en&user=v8c0yCEAAAAJ&view_op=list_works&sortby=pubdate)

SciProfiles (<https://sciprofiles.com/profile/162310>)

Department of Economics and Center for the Study of Public Choice, George Mason University, 4400 University Dr. Fairfax, VA 22030, USA

Interests: financial economics; interest rates; budget deficits; regional economics; migration; geographic living cost differentials; economic freedom



Assoc. Prof. Dr. Lynne Chester

Website (<https://sydney.edu.au/arts/ssps/staff/profiles/lynne.chester.php>)



Dr. George R.G. Clarke

Website (<http://www.grgclarke.com/>) **SciProfiles** (<https://sciprofiles.com/profile/780122>)

Division of International Banking and Finance Studies, A.R. Sanchez, Jr. School of Business, 5001 University Blvd, Laredo, TX 78041, USA

Interests: development economics; political economy; corruption; institutions; Africa; privatization; competition; firm surveys

Special Issues, Collections and Topics in MDPI journals

Special Issue in ***Economies: Impact of Corruption on the Economy***

(/journal/economies/special_issues/Impact_Corruption_Economy)

Special Issue in ***Economies: Determinants of Firm Performance in Developing Countries***

(/journal/economies/special_issues/Determinants_Firm_Performance_Developing_Countries)

Prof. Dr. Kevin Daly

Website (https://www.westernsydney.edu.au/staff_profiles/uws_profiles/professor_kevin_daly)

SciProfiles (<https://sciprofiles.com/profile/1071481>)

School of Business, Western Sydney University, Penrith, NSW, Australia

Interests: applied finance; open economy macroeconomics

Prof. Dr. David O. Dapice

Website (<https://ash.harvard.edu/people/david-dapice>)

1. Emeritus Professor at Department of Economics, Tufts University, 8 Upper Campus Road, Braker Hall, Medford, MA 02155, USA

2. Ash Center for Democratic Governance and Innovation, Harvard Kennedy School, 79 John F. Kennedy Street, Mailbox 74, Cambridge, MA 02138, USA

Interests: development economics; Southeast Asia

Special Issues, Collections and Topics in MDPI journals

Special Issue in ***Economies: Economic Development in Southeast Asia*** (/journal/economies/special_issues/southeastasia)

Dr. Gaurav Datt

Website (<https://sites.google.com/view/gauravdatt/home>)

Deputy Director, Centre for Development Economics and Sustainability, Monash University, Melbourne, Australia

Interests: poverty; inequality; development; labour

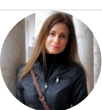

Dr. Andreia Dionísio

Website (<https://www.uevora.pt/pessoas?id=15974>)

Departamento de Gestão de Empresas, CEFAGE, Universidade de Évora, Évora, Portugal

Interests: econometrics; econophysics; financial markets; fuzzy models; data analysis

Special Issues, Collections and Topics in MDPI journals

Special Issue in ***Economies: Impact of Macroeconomic Indicators on Stock Market***

(/journal/economies/special_issues/macro_stockmarket)

Special Issue in ***Journal of Risk and Financial Management: Stock Markets Behavior***

(/journal/jrfm/special_issues/Stock_Markets_Behavior)

Topical Collection in ***Journal of Risk and Financial Management: Financial Markets—The Response in Crisis Moments***

(/journal/jrfm/special_issues/Financial_Markets_Crisis)

Special Issue in ***Economies: Econophysics*** (/journal/economies/special_issues/econophysics)

Prof. Dr. Roland Döhrn

Website (<https://www.oek.wiwi.uni-due.de/en/team/roland-doehrn/>)



Prof. Dr. Christian Dreger

Website (<http://www.christian-dreger.de/>)

Deutsches Institut für Wirtschaftsforschung (DIW), 10117 Berlin, Germany

Interests: econometric forecasting; tools for policy simulation; Chinese economy; European monetary union and integration; emerging markets; monetary economics



Prof. Dr. Nick Drydakis

Website1 (<https://aru.ac.uk/people/nick-drydakis>) **Website2** (<https://www.pem.cam.ac.uk/college/master-and-fellows/list-fellows/professor-nick-drydakis>)

1. Centre for Pluralist Economics, Faculty of Business and Law, Anglia Ruskin University, Cambridge CB1 1PT, UK

2. Pembroke College, University of Cambridge, Cambridge CB2 1RF, UK

Interests: technology-enabled innovation; artificial intelligence; labor markets; growth; development; business performance; digital transformation; digital divide; apps and outputs

Special Issues, Collections and Topics in MDPI journals

Special Issue in **Sustainability: Migration-Refugee Policies and Socioeconomics, Well-Being and Sustainable Outcomes** (/journal/sustainability/special_issues/Sus_migration_sustainableoutcomes).

Special Issue in **Economies: Technological Advances, Nations and Business-Wide Activity and Growth** (/journal/economies/special_issues/technological_advances).

Prof. Dr. Juan Antonio Duro

Website (<https://www.urv.cat/en/about/get-to-know/people/teaching-staff-positions/14/juan-antonio-duro>)

Departament d'Economia, Universitat Rovira i Virgili, Av. de la Universitat, 1 - 43204 Reus, Spain

Interests: environmental economics; tourism economics

Assoc. Prof. Dr. Nabamita Dutta

Website (<https://sites.google.com/site/duttanabamita/>) **SciProfiles** (<https://sciprofiles.com/profile/583795>)

Department of Economics, College of Business Administration, University of Wisconsin-La Crosse, 1725 State St, La Crosse, WI 54601, USA

Interests: new institutional economics; economic development; gender; entrepreneurship; political economy

Special Issues, Collections and Topics in MDPI journals

Special Issue in **Economies: Gender and Economic Development: The South Asian Experience** (/journal/economies/special_issues/gender_economic).

Dr. Balázs Égert

Website (https://www.oecd.org/eco/Balazs_Egert_OECD_CV.pdf)

Economics Department, Organisation for Economic Co-operation and Development (OECD), Paris, France

Interests: macroeconomics; international economics; structural policies



Prof. Dr. Simon Feeny

Website (<https://www.rmit.edu.au/contact/staff-contacts/academic-staff/feeny-professor-simon>)

International Development and Trade Research Group, RMIT University, Melbourne, VIC 3000, Australia

Interests: development economics

Prof. Dr. William D. Ferguson

Website (<https://bferguson.sites.grinnell.edu/>)

Economics Department, Grinnell College, 1210 Park Street, Grinnell, IA 50112, USA

Interests: political economy of development; institutional political economy; and collective action, particularly with a game-theoretic approach; inequality; labor economics

Special Issues, Collections and Topics in MDPI journals

Special Issue in ***Economies: Game Theory and Political Economy*** (/journal/economies/special_issues/game-theories)



Prof. Dr. Bernd Frick

Website (<https://wiwi.uni-paderborn.de/dep1/frick/team/prof-dr-bernd-frick>)

Paderborn University, Management Department, Warburger Straße 100, D-33098 Paderborn, Germany

Interests: organizational and sports economics



Dr. Ștefan Cristian Gherghina

Website (<http://stefangherghina.ase.ro/>) **SciProfiles** (<https://sciprofiles.com/profile/143745>)

Department of Finance, Faculty of Finance and Banking, Bucharest University of Economic Studies, 6 Piata Romana, 1st District, Bucharest, Romania

Interests: corporate finance; corporate governance; quantitative finance; energy economics; environmental economics; sustainable development

Special Issues, Collections and Topics in MDPI journals

Special Issue in ***Sustainability: Resilient Infrastructure Systems and Sustainable Economic Growth***

(/journal/sustainability/special_issues/Economic_growth)

Special Issue in ***Journal of Risk and Financial Management: Corporate Finance***

(/journal/jrfm/special_issues/Corporate_Finance)

Special Issue in ***Journal of Risk and Financial Management: Corporate Finance, Governance, and Social Responsibility***

(/journal/jrfm/special_issues/CFGSR)

Special Issue in ***Economies: The Impact of COVID-19 on Financial Markets and the Real Economy***

(/journal/economies/special_issues/Impact_COVID_19_Financial_Markets_Real_Economy)

Special Issue in ***Sustainability: The Impact of COVID-19 Pandemic on Sustainable Development Goals***

(/journal/sustainability/special_issues/sustainable_development_goals)

Special Issue in ***Economies: Commodity Markets' Reaction to COVID-19 Outbreak***

(/journal/economies/special_issues/Commodity_Markets_Reaction_COVID19_Outbreak)



Prof. Dr. George Halkos

Website (<https://www.econ.uth.gr/en/department/staff/faculty/35-dr-george-halkos>)

SciProfiles (<https://sciprofiles.com/profile/294846>)

Laboratory of Operations Research, Department of Economics, University of Thessaly, 28hs Octovriou 78, 383 33 Volos, Greece

Interests: applied statistics and econometrics; simulations of economic modelling; environmental economics; applied micro-economic with emphasis in welfare economics; air pollution; game theory; mathematical models (non-linear programming)

Special Issues, Collections and Topics in MDPI journals

Special Issue in ***Energies: Assessment of Energy–Environment–Economy Interrelations***

(/journal/energies/special_issues/energy_environment_economy_interrelations)

Special Issue in ***Sustainability: Economic Impacts of Energy and Climate Change Mitigation and Adaptation***

(/journal/sustainability/special_issues/energy_and_climate_change_mitigation_and_adaptation)

Special Issue in ***Economies: Current Issues in Natural Resource and Environmental Economics***

(/journal/economies/special_issues/nature_environment_economics)

Special Issue in ***Energies: Economic Analysis and Policies for the Environment, Natural Resources and Energy***

(/journal/energies/special_issues/E_A_P_P_E_N_R_E)

Special Issue in ***Journal of Risk and Financial Management: Risk and Financial Consequences*** (toggle desktop layout cookie) 🔍 ☰

(/journal/jrfm/special_issues/Risk_Finacial_Consequences)

Special Issue in ***Energies: Modeling Energy–Environment–Economy Interrelations***

(/journal/energies/special_issues/modelling_energy_environment_economy_interrelations)

Special Issue in ***Sustainability: Water Resources and Sustainable Development: Social, Economic, Psychological and Educational Perspectives*** (/journal/sustainability/special_issues/Water_Resources_Sustainable_Development)

Special Issue in ***Economies: Challenges in Environmental and Resource Economics***

(/journal/economies/special_issues/EnvironmentalResourceEconomics)

Special Issue in ***Energies: Selected Papers from the 6th ENVECON Conference “Economics of Natural Resources and the Environment”*** (/journal/energies/special_issues/6th_ENVECON)

Special Issue in ***Sustainability: Resource Price Fluctuations and Sustainable Growth***

(/journal/sustainability/special_issues/resource_price_fluctuations_sustainable_growth)



Prof. Dr. Hardy Hanappi

Website (<http://www.econ.tuwien.ac.at/hanappi/>). **SciProfiles** (<https://sciprofiles.com/profile/973128>)

1. Mathematics and Geo-Information Department, Vienna University of Technology, Karlsplatz 13, 1040 Wien, Austria

2. Political Economy of European Integration Institute 105-3, SWM Economics, University of Technology of Vienna, Wiedner Hauptstrasse 6-8, A-1040 Vienna, Austria

Interests: evolutionary economics; Euro zone; Game Theory; information science and knowledge models; financial reform; political economy; development economics

Special Issues, Collections and Topics in MDPI journals

Special Issue in ***Economies: Breakpoint of the Euro Zone?*** (/journal/economies/special_issues/euro_zone)



Prof. Dr. Tsutomu Harada

Website (<https://b.kobe-u.ac.jp/en/faculty/harada/>)

Graduate School of Business Administration, Kobe University, 1-1, Rokkodaicho, Nada Ward, Kobe, Hyōgo Prefecture 657-0013, Japan

Interests: innovation; technological change; economic growth; inter-sectoral growth

Special Issues, Collections and Topics in MDPI journals

Special Issue in ***Economies: Innovation and Economic Development***

(/journal/economies/special_issues/economic_development)

Dr. Edward C. Hoang

Website (<http://www.uccs.edu/ehoang>)

Department of Economics, University of Colorado at Colorado Springs, 1420 Austin Bluffs Parkway, Colorado Springs, CO 80918, USA

Interests: macroeconomics; macroeconomic policy analysis; public economics

Special Issues, Collections and Topics in MDPI journals

Special Issue in ***Economies: The Role of Education and Health in Economic Development***

(/journal/economies/special_issues/education-health-economic-development)

Special Issue in ***Economies: The Economics of Health Outbreaks and Epidemics***

(/journal/economies/special_issues/Economics_Health_Outbreaks_Epidemics)

Dr. Abbi M. Kedir

Website (<https://www.sheffield.ac.uk/management/people/academic-staff/abbi-kedir>)



Prof. Dr. Tatyana Khudyakova

Website (<https://www.susu.ru/ru/employee/hudyakova-tatyana-albertovna>).

SciProfiles (<https://sciprofiles.com/profile/572841>).

Department of Digital Economy and Information Technology, South Ural State University, 454080 Chelyabinsk, Russia

Interests: sustainable development; smart cities; environmental economics; regional economics



Dr. Manfred Kircher

Website (<https://www.kadib.de/>) **SciProfiles** (<https://sciprofiles.com/profile/733505>).

KADIB Kircher Advice in Bioeconomy, 60431 Frankfurt am Main, Germany

Interests: bioeconomy; circular economy; chemical industries; fuel industries

Prof. Dr. Stephan Klasen

Website (<https://www.iza.org/person/146/stephan-klasen>).

University of Göttingen, Platz der Göttinger Sieben 3, 37073 Göttingen, Germany

Prof. Dr. Lea-Rachel Kosnik

Website (<http://www.umsl.edu/~kosnik/>) **SciProfiles** (<https://sciprofiles.com/profile/254003>).

Economics Department, University of Missouri-St. Louis, St. Louis County, MO 63121, USA

Interests: environment; energy; water quality; air quality; climate change; sustainability; negative externality; renewable resources; fossil fuels; and hydropower

Dr. Brantley Liddle

Website (<https://scholar.google.com.au/citations?user=NVmMD5wAAAAJ&hl=en>).

SciProfiles (<https://sciprofiles.com/profile/281455>).

Energy Studies Institute, National University of Singapore, Singapore 119620, Singapore

Interests: energy economics and policy; energy and climate change; economic growth and energy/environment; transport and energy/environment; population and energy/environment

Special Issues, Collections and Topics in MDPI journals

Special Issue in ***Sustainability: Sustainable Transport: Transport, Environment, and Development***

(/journal/sustainability/special_issues/Transport_Environment_and_Development).

Special Issue in ***Sustainability: Population Dynamics in the Changing Climate Systems***

(/journal/sustainability/special_issues/Population_Dynamics).

Prof. Dr. Pushkar Maitra

Website (<http://users.monash.edu.au/~maitra/>).

Department of Economics, Monash University, Clayton Campus, VIC 3800, Australia

Interests: development economics; population economics; experimental economics; applied econometrics



Prof. Dr. António C. Marques

Website (<http://www.ubi.pt/Pessoa/amarques>) **SciProfiles** (<https://sciprofiles.com/profile/556950>).

NECE-UBI, Research Unit in Business Science and Economics, University of Beira Interior, Rua Marquês d'Ávila e Bolama, 6201-001 Covilhã, Portugal



Prof. Dr. José M. Martínez-Paz

Website (<https://webs.um.es/jmpaz/>) **SciProfiles** (<https://sciprofiles.com/profile/526868>)

Department of Applied Economics, Faculty of Economics and Business, University of Murcia, 30100 Murcia, Spain

Interests: water economics; agricultural economics; environmental economics

Special Issues, Collections and Topics in MDPI journals

Special Issue in ***Water: Socioeconomic Indicators for Sustainable Water Management***

(/journal/water/special_issues/Socioeconomic_Indicators_Water_Management)



Dr. Adolfo Maza

Website (<https://scholar.google.es/citations?user=kdkksR4AAAAJ>) **SciProfiles** (<https://sciprofiles.com/profile/770919>)

Dpto. de Economía, Universidad de Cantabria, Avda. de los Castros, s.n., 39005 Santander, Spain

Interests: labour market; migration; growth; investment; regional economics

Special Issues, Collections and Topics in MDPI journals

Special Issue in ***Economies: Migration and Economic Development***

(/journal/economies/special_issues/migration_economic)



Dr. Angeliki N. Menegaki

Website (<https://livedna.net/?dna=30.8498>) **SciProfiles** (<https://sciprofiles.com/profile/798635>)

Department of Economics & Management of Tourist and Culture Units, Agricultural University of Athens, 33100 Amfissa, Greece

Interests: climate change; energy economics; valuation; renewable energy; economic growth; sustainable energy; energy policy; energy management; sustainability; tourism economics and the environment

Special Issues, Collections and Topics in MDPI journals

Special Issue in ***Economies: Energy Economy in the New Century***

(/journal/economies/special_issues/Reviews_Success_Stories_Renewable_Clean_Energy_Implementation)



Prof. Dr. Michele Meoli

Website (<https://cshe.berkeley.edu/people/michele-meoli>) **SciProfiles** (<https://sciprofiles.com/profile/668012>)

Department of Management, Information and Production Engineering, University of Bergamo, 24129 Bergamo, Italy

Interests: corporate finance; corporate governance; entrepreneurial finance; academic entrepreneurship; higher education and research policy

Prof. Dr. Pierre-Guillaume Méon

Website (<https://scholar.google.be/citations?user=2zWixsAAAAAJ&hl=fr>)

Solvay Brussels School of Economics and Management, Université libre de Bruxelles (U.L.B.), Avenue Franklin Roosevelt 50, 1050 Bruxelles, Belgium

Interests: political macroeconomics; economic integration

Special Issues, Collections and Topics in MDPI journals

Special Issue in ***Economies: New Institutional Economics*** (/journal/economies/special_issues/N_institu_eco)

Prof. Dr. Tapas Mishra

Website (<https://www.southampton.ac.uk/business-school/about/staff/tkm1u13.page>)

SciProfiles (<https://sciprofiles.com/profile/991182>)

Southampton Business School, University of Southampton, Southampton, Building 2, Highfield Campus, Southampton SO9 10 5D, UK

Interests: timeseries econometrics; economic growth; spatiotemporal econometrics; nonlinear modelling in economics and finance; stochastic environment and demography; financial market volatility under uncertainty

Special Issues, Collections and Topics in MDPI journals

Special Issue in ***Economies: The Application of Time Series Analysis in Economic Growth***

(/journal/economies/special_issues/Application_Time_Series).

Special Issue in ***Economies: Competition Effects of Innovation under Uncertain Times***

(/journal/economies/special_issues/Competition_Effects_Innovation_Uncertain_Times).

Prof. Dr. Devashish Mitra

Website (<https://dmitra.expressions.syr.edu/>)

The Maxwell School of Citizenship and Public Affairs, Syracuse University, Syracuse, NY 13244, USA

Interests: international trade; political economy; development economics

Special Issues, Collections and Topics in MDPI journals

Special Issue in ***Economies: Globalization and Inequality*** (/journal/economies/special_issues/globalization_and_inequality).



Prof. Dr. Franklin G. Mixon

Website (<https://scholar.google.com/citations?user=9cT8V7YAAAAJ&hl=en>)

SciProfiles (<https://sciprofiles.com/profile/50075>)

Center for Economic Education, Columbus State University, Columbus, GA 31907, USA

Interests: public choice; labor economics; industrial organization; sports economics

Special Issues, Collections and Topics in MDPI journals

Special Issue in ***Economies: Public Choice*** (/journal/economies/special_issues/Public_Choice)

Special Issue in ***Sustainability: Common-Pool Resources and Sustainability*** (/journal/sustainability/special_issues/Common)

Special Issue in ***Economies: Advances in Sports Economics*** (/journal/economies/special_issues/sports_economics)

Special Issue in ***Sustainability: Labor Economics and Sustainability***

(/journal/sustainability/special_issues/labor_economics_sus).

Special Issue in ***Economies: Sociology of Economics*** (/journal/economies/special_issues/Sociology_Economics)



Dr. Bruce Morley

Website (<https://people.bath.ac.uk/bm232/bm-research.htm#reports>) **SciProfiles** (<https://sciprofiles.com/profile/753945>)

Department of Economics & International Development, University of Bath, Bath BA2 7AY, UK

Interests: international macroeconomics and finance; economic growth and the main determinants of growth; trade and the determinants of foreign direct investment; European economics and the Performance of the Euro; sport economics, in particular relating to cricket

Special Issues, Collections and Topics in MDPI journals

Special Issue in ***Economies: Forecasting on International Financial Risk***

(/journal/economies/special_issues/Forecasting_International_Financial_Risk).



Prof. Dr. Ragnar Nymoén

Website (<https://www.sv.uio.no/econ/english/people/aca/rnymoen/index.html>)

Prof. Dr. Dorian Owen

Website (<https://www.otago.ac.nz/economics/staff/otago077911.html>)

Department of Economics, University of Otago, PO Box 56, Dunedin 9054, New Zealand

Interests: empirical modelling of economic growth and development; sports economics; applied econometrics



Prof. Dr. Aleksander Panasiuk

Website (<https://przedsiebiorczosc.uj.edu.pl/aleksander-panasiuk>) **SciProfiles** (<https://sciprofiles.com/profile/719481>)

Jagiellonian University in Krakow, Institute of Entrepreneurship, Tourism and Sport Management Chair, 72-005 Kraków, Poland

Interests: management; entrepreneurship; service economics; service management; tourism economics; tourism management; leisure studies; sport management; service marketing; regional policy

Special Issues, Collections and Topics in MDPI journals

Special Issue in ***Economies: Tourism Economics*** (/journal/economies/special_issues/Tourism_1_Economics)

Special Issue in ***Economies: Hotel Industry – Perspective during and Post COVID-19***

(/journal/economies/special_issues/Hotel_Industry_Perspective_Post_COVID_19).

Special Issue in ***Businesses: Entrepreneurship in Sport, Tourism and the Public Sector***

(/journal/businesses/special_issues/entrepreneurship_sport_tourism_public).



Prof. Dr. Lourenco Paz

Website (https://business.baylor.edu/directory/?id=Lourenco_Paz) **SciProfiles** (<https://sciprofiles.com/profile/451080>)

Hankamer School of Business, Baylor University, Waco, TX 76798, USA

Interests: international trade; development economics; labor economics; public finance; international macro and finance; Latin America

Special Issues, Collections and Topics in MDPI journals

Special Issue in ***Economies: International Trade and Its Intersection with Development, Labor, and Public Economics***

(/journal/economies/special_issues/international_trade)



Prof. Dr. Gheorghe H. Popescu

Website (https://scholar.google.ro/citations?hl=en&user=pQ4kwREAAA&view_op=list_works&sortby=pubdate)

1. Dimitrie Cantemir Christian University, Splaiul Unirii 176, Bucharest, Romania

2. Center for Applied Macroeconomic Analysis at the American Association for Economic Research, 30-18 50th Street, Woodside, New York City, NY 11377, USA

Interests: macroeconomics; labor economics and policies; economic governance; sustainable development

Special Issues, Collections and Topics in MDPI journals

Special Issue in ***Sustainability: Sustainable Development and Entrepreneurship in Contemporary Economies***

(/journal/sustainability/special_issues/sustainable-development-entrepreneurship)

Special Issue in ***Economies: Macroeconomics and Urban Labor Markets Paradigms***

(/journal/economies/special_issues/markets_paradigms)

Special Issue in ***Sustainability: Resilient Economics and the Regional Sustainable Economic Growth***

(/journal/sustainability/special_issues/resilient_economics)

Special Issue in ***Sustainability: Towards Resilient Entrepreneurship and Technological Development in Self-Sustainable Economies*** (/journal/sustainability/special_issues/Entrepreneurship_sustainability)



Prof. Dr. Sanzidur Rahman

Website (<https://scholar.google.com/citations?user=b-CgrTEAAAAJ&hl=en>)

SciProfiles (<https://sciprofiles.com/profile/145366>)

School of Agriculture, Policy and Development (SAPD), University of Reading, Reading RG6 6UR, UK

Interests: agricultural economics; productivity and efficiency; technological progress in agriculture; sustainable agriculture; sustainable livelihoods; poverty and nutrition; international development

Special Issues, Collections and Topics in MDPI journals

Special Issue in **Agriculture: Agriculture and Rural Development** (/journal/agriculture/special_issues/rural_development)

Special Issue in **Sustainability: Sustainable Agriculture and Development**

(/journal/sustainability/special_issues/Sustainable_agriculture_development)

Special Issue in **Agriculture: Energy and Agriculture** (/journal/agriculture/special_issues/energy)

Special Issue in **Sustainability: Economics of Climate Smart Agriculture** (/journal/sustainability/special_issues/ECSA)

Special Issue in **Energies: Agriculture and Energy 2019** (/journal/energies/special_issues/agriculture_and_energy_2019)

Special Issue in **Agriculture: Productivity, Efficiency, and Sustainability in Agriculture**

(/journal/agriculture/special_issues/Sustainability_Agriculture)

Special Issue in **Agriculture: Agriculture: 10th Anniversary** (/journal/agriculture/special_issues/agriculture_anniversary)

Special Issue in **Land: Agricultural Land Management to Meet Future Global Food Demand**

(/journal/land/special_issues/agricultural_land_food)

Special Issue in **Agriculture: Productivity, Efficiency and Sustainability Challenges in Developing High Value and/or High Quality Agriculture in Developing Economies** (/journal/agriculture/special_issues/Agriculture_Economies)

Prof. Dr. Priya Ranjan

Website (<https://faculty.sites.uci.edu/prjha/>)

Department of Economics, University of California, Irvine, CA 92697, USA

Interests: international economics; economic growth and development

Prof. Dr. Hans-Eggert Reimers

Website (https://www.wi.hs-wismar.de/de/personen_ausstattung/professoren/view/d/hans_eggert.reimers)

Faculty of Business, Hochschule Wismar, University of Applied Sciences Technology, Business and Design, Postfach 12 10, D - 23952 Wismar, Germany

Interests: empirical macroeconomics; financial economics; applied econometrics



Prof. Dr. Angela Roman

Website (<https://www.feaa.uaic.ro/faculty/angela-roman>) **SciProfiles** (<https://sciprofiles.com/profile/306996>)

Department of Finance, Money and Public Administration, Faculty of Economics and Business Administration, Alexandru Ioan Cuza University of Iasi, 700505 Iasi, Romania

Interests: banks; monetary policy; entrepreneurship; small and medium enterprises, public finance, european financial integration



Prof. Dr. Roberta Salomone

Website (<https://www.unime.it/it/persona/roberta-salomone/curriculum>)

Department of Economics, University of Messina, Piazza Pugliatti, 1, 98122 Messina ME, Italy

Interests: environmental management; industrial ecology; life cycle assessment; circular economy



Prof. Dr. Luca Salvati

Website (<https://docenti.unimc.it/luca.salvati>) **SciProfiles** (<https://sciprofiles.com/profile/408818>)

Department of Economics and Law, University of Macerata, Via Armaroli 43, I-62100 Macerata, Italy

Interests: climate change; desertification; land-use; sustainable agriculture; urban sprawl; urban and rural geography

Special Issues, Collections and Topics in MDPI journals

Special Issue in **Sustainability: Urbanization and Demographic Change: A New Step Ahead in Understanding of World**

Regional Complexity

(/journal/sustainability/special_issues/urbanization_demographic_change_world_regional_complexity)

Special Issue in **Sustainability: Urban Sprawl and Sustainability** (/journal/sustainability/special_issues/Sprawl)

Special Issue in **Sustainability: Soil Ecosystem Services, Land Planning, Landscape Design and Management**

(/journal/sustainability/special_issues/land_management)

Special Issue in **Sustainability: Urban Sprawl and Sustainability II** (/journal/sustainability/special_issues/Urban_Sprawl_II)

Special Issue in **Land: Recent Progress in Urbanisation Dynamics Research**

(/journal/land/special_issues/Urbanisation_Dynamics)

Special Issue in **Geographies: Feature Papers of Geographies in 2021**

(/journal/geographies/special_issues/feature_papers_geographies)

Dr. Joost Santos

Website (<https://www.seas.gwu.edu/joost-santos>) **SciProfiles** (<https://sciprofiles.com/profile/2355475>)

Department of Engineering Management & Systems Engineering, The George Washington University, Washington, DC 20052, USA

Interests: risk assessment; econometrics; financial economics; risk management; risk analysis; economic geography; financial engineering; input-output analysis; investment



Prof. Dr. Franz Seitz

Website (<http://www.oth-aw.de/seitz>) **SciProfiles** (<https://sciprofiles.com/profile/658522>)

Ostbayerische Technische Hochschule Weiden, Weiden Technical University of Applied Sciences, Hetzenrichter Weg 15, D-92637

Weiden, Germany

Interests: monetary theory; monetary policy; payments markets; cash; euro



Prof. Dr. Wadim Strielkowski

Website (<https://www.pbs-education.cz/strielkowski/>) **SciProfiles** (<https://sciprofiles.com/profile/108505>)

1. Centre for Energy Studies, Prague Business School, Prague, Werichova 1145/29, 152 00 Praha 5 Prague, Czech Republic

2. Cambridge Institute for Advanced Studies, Cambridge, UK

Interests: energy economics; labor economics; tourism economics; international migration

Special Issues, Collections and Topics in MDPI journals

Special Issue in **Energies: Market Design for a High-Renewables Electricity System**

(/journal/energies/special_issues/MD_HRES)

Special Issue in **Economies: Leadership in Business and Economics**

(/journal/economies/special_issues/leadership_business_economics)

Special Issue in **Sustainability: Sustainability of the High-Renewables Smart Grids**

(/journal/sustainability/special_issues/Sustainability_High-Renewables_Smart_Grids)

Special Issue in ***Economies: Novel Insights in the Leadership in Business and Economics***
(/journal/economies/special_issues/Novel_Insights_Leadership_Business_Economics)

Prof. Dr. Bedassa Tadesse

 [\(/toggle desktop layout cookie\)](#)  

Website (<https://lsbe.d.umn.edu/faculty-staff/bedassa-tadesse-phd>)

Department of Economics, University of Minnesota-Duluth, 1318 Kirby Dr., Duluth, MN 55812, USA

Interests: international economics; international migration; econometrics and development economics



Prof. Dr. Wing-Keung Wong

Website (<http://dns2.asia.edu.tw/~wong/>) **SciProfiles** (<https://sciprofiles.com/profile/278080>)

1. Department of Finance, College of Management, Asia University, Wufeng, Taichung 407705, Taiwan

2. Department of Medical Research, China Medical University Hospital, Taichung City, Taiwan

3. Department of Economics and Finance, The Hang Seng University of Hong Kong, Hong Kong, China

Interests: behavioral models; mathematical modeling; econometrics; energy economics; equity analysis; investment theory; risk management; behavioral economics; operational research; decision theory; environmental economics; public health; time series analysis; forecasting

Special Issues, Collections and Topics in MDPI journals

Special Issue in ***Economies: Efficiency and Anomalies in Stock Markets*** (/journal/economies/special_issues/anomalies-stockmarkets)

Special Issue in ***Sustainability: Risk Measures with Applications in Finance and Economics***
(/journal/sustainability/special_issues/Risk_finance_sustainability)

Special Issue in ***Risks: Measuring and Modelling Financial Risk and Derivatives***
(/journal/risks/special_issues/financial_risk_derivatives)

Special Issue in ***Sustainability: Sustainability of the Theories Developed by Mathematical Finance and Mathematical Economics with Applications*** (/journal/sustainability/special_issues/Mathematical_Finance)

Special Issue in ***Journal of Risk and Financial Management: Mathematical Finance with Applications***
(/journal/jrfm/special_issues/mathematical_finance_applications)

Special Issue in ***International Journal of Environmental Research and Public Health: Mathematical and Statistical Models in Environmental Research and Public Health with Applications*** (/journal/ijerph/special_issues/MSMERPHA)

Special Issue in ***Economies: Asset Pricing, Investment, and Trading Strategies***
(/journal/economies/special_issues/price_investment_trade)

Special Issue in ***Energies: Mathematical and Statistical Models for Energy with Applications***
(/journal/energies/special_issues/math_stat_models)

Special Issue in ***Sustainability: Behavioral Business and Behavioral Financial Economics with Applications***
(/journal/sustainability/special_issues/Behavioral_Business)

Special Issue in ***Journal of Risk and Financial Management: Risk and Financial Management of COVID-19 in Business, Economics and Finance*** (/journal/jrfm/special_issues/COVID-19_Business_Economics_Finance)

Special Issue in ***International Journal of Environmental Research and Public Health: Behavioral Models in Environmental Research and Public Health with Applications*** (/journal/ijerph/special_issues/MPERPHA)

Special Issue in ***Journal of Risk and Financial Management: Accounting, International Finance, and Economic Development with Applications*** (/journal/jrfm/special_issues/accounting_Finance)

Special Issue in ***Risks: Mathematical and Statistical Models on Risk with applications in Business, Economics, Finance, and COVID-19*** (/journal/risks/special_issues/Math_Stat_Models_Risk)



Special Issue in ***Mathematical and Computational Applications: Mathematical and Computational Applications in Finance and Economics*** (/journal/mca/special_issues/Finance_Econ)

Special Issue in ***Energies: Behavioral Models for Energy with Applications***
(/journal/energies/special_issues/behavioral_models)

Special Issue in ***Journal of Risk and Financial Management: A Commemorative Issue in Honor of Professor Michael McAleer, 1951–2021*** (/journal/jrfm/special_issues/Commemorative_Issue)

Special Issue in ***Economies: Financial Economics: Theory and Applications***
(/journal/economies/special_issues/Financial_Economics_Theory_Applications)

Prof. Dr. Burcin Yurtoglu

 [\(/toggle_desktop_layout_cookie\)](#)  

Website (<https://www.whu.edu/de/fakultaet/finance-and-accounting-group/corporate-finance/b-burcin-yurtoglu/>).

SciProfiles (<https://sciprofiles.com/profile/901083>).

WHU - Otto Beisheim School of Management, Burgplatz 2, 56179 Vallendar, Germany

Interests: corporate finance; corporate governance; emerging markets

Economies ([/journal/economies](https://www.mdpi.com/journal/economies)), EISSN 2227-7099, Published by MDPI **[Disclaimer](#)**

RSS ([/rss/journal/economies](https://www.mdpi.com/rss/journal/economies)) **Content Alert** ([/journal/economies/toc-alert](https://www.mdpi.com/journal/economies/toc-alert)).

Further Information

Article Processing Charges ([/apc](#)).

Pay an Invoice ([/about/payment](#)).

Open Access Policy ([/openaccess](#)).

Contact MDPI ([/about/contact](#)).

Jobs at MDPI (<https://careers.mdpi.com>).

Guidelines

For Authors ([/authors](#)).

For Reviewers ([/reviewers](#)).

For Editors ([/editors](#)).

For Librarians ([/librarians](#)).

For Publishers ([/publishing_services](#)).

For Societies ([/societies](#)).

For Conference Organizers ([/conference_organizers](#)).

MDPI Initiatives

Sciforum (<https://sciforum.net>).

MDPI Books (<https://www.mdpi.com/books>).

Preprints (<https://www.preprints.org>).

Scilit (<https://www.scilit.net>).

SciProfiles (<https://sciprofiles.com>).

Encyclopedia (<https://encyclopedia.pub>).

JAMS (<https://jams.pub>).

Proceedings Series ([/about/proceedings](#)).

Follow MDPI

LinkedIn (<https://www.linkedin.com/company/mdpi>).

Facebook (<https://www.facebook.com/MDPIOpenAccessPublishing>).

Twitter (<https://twitter.com/MDPIOpenAccess>).

 **Subscribe to receive issue release notifications and newsletters from MDPI journals**

Select options ▼

Enter your email address...

Subscribe

 [\(/toggle_desktop_layout_cookie\)](#)  

© 1996-2022 MDPI (Basel, Switzerland) unless otherwise stated

[Disclaimer](#) [Terms and Conditions \(/about/terms-and-conditions\)](#) [Privacy Policy \(/about/privacy\)](#)

Economies, Volume 10, Issue 7 (July 2022) – 25 articles



Cover Story ([view full-size image \(/files/uploaded/covers/economies/big_cover-economies-v10-i7.png\)](#)): Cretan olive oil is known for its premium quality worldwide. Olive oil exports affect both the financial growth and stability of companies that trade it and the economic prosperity of the prefecture of Crete. The aim of this paper is to investigate the influence of export managers on export marketing policies. The findings of the research indicate the influence that export managers have on promotions abroad and on the conduction of market research before Cretan olive oil is exported to a new foreign market. The employment of an export manager and the level of their certified knowledge appear to have a positive impact on the export marketing policies of companies that export Cretan olive oil. [View this paper \(https://www.mdpi.com/2227-7099/10/7/152\)](#).

(<https://www.mdpi.com/2227-7099/10/7/152>)

regarded as officially published after their release is announced to the [table of contents alert mailing list \(/journal/economies/toc-alert\)](#).

- You may [sign up for e-mail alerts \(/journal/economies/toc-alert\)](#) to receive table of contents of newly released issues.
- PDF is the official format for papers published in both, html and pdf forms. To view the papers in pdf format, click on the "PDF Full-text" link, and use the free [Adobe Reader \(https://www.adobe.com/\)](#) to open them.

Order results

Publication Date

Result details

Normal

Section

All Sections

[Show export options](#) ▾

Open Access Article

[Download PDF \(/2227-7099/10/7/176/pdf?version=1658463471\)](#)

The Impact of Changes in Financial Supervision on the Profitability of the Hungarian Banking Sector ([/2227-7099/10/7/176](#))

by [Tibor Bareith \(https://sciprofiles.com/profile/1691962\)](#), [Tibor Tatay \(https://sciprofiles.com/profile/1207933\)](#) and [József Varga \(https://sciprofiles.com/profile/author/YS9MeXhyRzhVN1VWcG9nWDILakUwWUs3TEp3VzFleVdOOUgwNWE5ckFaMD0=\)](#)

Economies **2022**, *10*(7), 176; <https://doi.org/10.3390/economies10070176> (<https://doi.org/10.3390/economies10070176>) - 21 Jul 2022

Viewed by 337

Abstract Since 2013, the central bank has been responsible for supervision in Hungary. In addition to the regulatory change, a law was published in the same year that started the process of abolishing the savings co-operative system. This paper investigates the impact of these [...] [Read more](#).

(This article belongs to the Section [Macroeconomics, Monetary Economics, and Financial Markets](#)

([/journal/economies/sections/macroeconomics_monetary_economics_financial_markets](#)))

[► Show Figures](#)

([/economies/economies-10-00176/article_deploy/html/images/economies-10-00176-g001-550.jpg](#))

Open Access Article

[Download PDF \(/2227-7099/10/7/175/pdf?version=1658314630\)](#)

Financial Distress, Firm Life Cycle, and Corporate Restructuring Decisions: Evidence from Pakistan's Economy ([/2227-7099/10/7/175](#))

by [Minhas Akbar \(https://sciprofiles.com/profile/606779\)](#), [Ammar Hussain \(https://sciprofiles.com/profile/2117116\)](#), [Marcela Sokolova \(https://sciprofiles.com/profile/1171740\)](#) and [Tanazza Sabahat \(https://sciprofiles.com/profile/author/dENGUEhjZkpJNGliS1pQK0hxbEJ4S1VEUXovM3R0ZkQ5SVJzbU5OVmc5MD0=\)](#)

Economies **2022**, *10*(7), 175; <https://doi.org/10.3390/economies10070175> (<https://doi.org/10.3390/economies10070175>) - 20 Jul 2022

Viewed by 371

Abstract This study examines the influence of financial distress on corporate restructuring decisions and whether this restructuring varies across the Firm Life Cycle (FLC) stages of Pakistani non-financial listed firms for the 12 years from 2005 to 2016 inclusive. FLC stages and financial distress [...] [Read more](#).

Open Access Article

[Download PDF \(/2227-7099/10/7/174/pdf?version=1658299199\)](#)

Effect of CSR on the Financial Performance of Financial Institutions in Kenya ([/2227-7099/10/7/174](#))

by [Martin Kamau Muchiri \(https://sciprofiles.com/profile/2254672\)](#), [Szilvia Erdei-Gally \(https://sciprofiles.com/profile/2191028\)](#) and [Mária Fekete-Farkas \(https://sciprofiles.com/profile/503043\)](#)

Economies **2022**, *10*(7), 174; <https://doi.org/10.3390/economies10070174> (<https://doi.org/10.3390/economies10070174>) - 19 Jul 2022

Viewed by 431

Abstract Corporate social responsibility (CSR) is an integral path towards realizing vision 2030 and the sustainable goals of the UN, as well as the sustainable development of individual countries. However, in recent years it has become increasingly clear that these goals cannot be achieved [...] [Read more](#).

(This article belongs to the Special Issue [Determinants of Firm Performance in Developing Countries](#) ([/journal/economies/special_issues/Determinants_Firm_Performance_Developing_Countries](#)))

Open Access Article

[Download PDF \(/2227-7099/10/7/173/pdf?version=1658717601\)](#)

Does Corruption Impact Firm Innovation? Evidence from Portugal ([/2227-7099/10/7/173](#))

by [Jorge Cerdeira](#) (<https://sciprofiles.com/profile/2199926>) and [Diogo Lourenço](#) (<https://sciprofiles.com/profile/2201385>)

Economies 2022, 10(7), 173; <https://doi.org/10.3390/economies10070173> (<https://doi.org/10.3390/economies10070173>) - 19 Jul 2022

Viewed by 416

Abstract This paper aims to analyze the impact of corruption on firm innovation in Portugal, using data from the World Bank Enterprise Surveys on 1062 firms for 2019. We employ regression analysis and instrumental variables techniques to account for endogeneity in the corruption variable. [...] [Read more](#).

Open Access Article

[./2227-7099/10/7/172/pdf?version=1658736634](#)

Exploring Regional Industrial Growth: Does Specialization Explain It? ([/2227-7099/10/7/172](#))

by [Leyla Gamidullaeva](#) (<https://sciprofiles.com/profile/415731>),

[Elena Korostyshevskaya](#) (<https://sciprofiles.com/profile/author/YmZVVnUrSkUzck16d08wejZmaU5iZFhld1I5OTNKWi9nR3F2cTcraTdjdz0=>),

[Alexey Myamlin](#) (<https://sciprofiles.com/profile/author/aDY0UjBUcI3RUxaU0xoZXJmG5WZ0IzY1B4a1pmRm9qU2pyb0IHVE5zOD0=>) and

[Olga Podkorytova](#) (<https://sciprofiles.com/profile/author/NWlna0o2WWEvVIlwanR0YUhlSlkxTXyYvYVJocmiZMk5rWWx2NHI0RDdPcz0=>)

Economies 2022, 10(7), 172; <https://doi.org/10.3390/economies10070172> (<https://doi.org/10.3390/economies10070172>) - 19 Jul 2022

Viewed by 382

Abstract Being a form of territorial division of labor, economic specialization should be considered as a strategic management priority, contributing to a competitive territorial production structure and, consequently, regional economic growth. The article is devoted, firstly, to the development of a method for assessing [...] [Read more](#).

(This article belongs to the Section [Economic Development, Growth, and Natural Resources \(Environment + Agriculture\)](#)

([/journal/economies/sections/economic_development_growth_natural_resources_environment+agriculture](#)))

[► Show Figures](#)

([/economies/economies-10-00172/article_deploy/html/images/economies-10-00172-g001-550.jpg](#))([/economies/economies-10-](#)

[00172/article_deploy/html/images/economies-10-00172-g002-550.jpg](#))

Open Access Article

[./2227-7099/10/7/171/pdf?version=1658201818](#)

A Bibliometric Analysis of the Developments and Research Frontiers of Agent-Based Modelling in Economics ([/2227-7099/10/7/171](#))

by [Aysha Zehra](#) (<https://sciprofiles.com/profile/2166259>) and [Amena Urooj](#) (<https://sciprofiles.com/profile/2275237>)

Economies 2022, 10(7), 171; <https://doi.org/10.3390/economies10070171> (<https://doi.org/10.3390/economies10070171>) - 19 Jul 2022

Viewed by 352

Abstract Dynamic Stochastic General Equilibrium (DSGE) models are widely used as a tool for policy decision-making. These models lost their fame when they could not predict the crisis in 2008 and could not address policy problems afterward. Meanwhile, the Agent-Based Modelling (ABM) approach emerged [...] [Read more](#).

(This article belongs to the Special Issue [Recent Topics in Economic Research – Feature Papers for Celebrating the 10th Anniversary of Economics](#) ([/journal/economies/special_issues/10th_Anniversary_Economics](#)))

([/journal/economies/special_issues/10th_Anniversary_Economics](#)))

[► Show Figures](#)

([/economies/economies-10-00171/article_deploy/html/images/economies-10-00171-g001-550.jpg](#))([/economies/economies-10-](#)

[00171/article_deploy/html/images/economies-10-00171-g002-550.jpg](#))([/economies/economies-10-00171/article_deploy/html/images/economies-10-00171-](#)

[g003-550.jpg](#))([/economies/economies-10-00171/article_deploy/html/images/economies-10-00171-g004-550.jpg](#))([/economies/economies-10-](#)

[00171/article_deploy/html/images/economies-10-00171-g005-550.jpg](#))([/economies/economies-10-00171/article_deploy/html/images/economies-10-00171-](#)

[g006-550.jpg](#))([/economies/economies-10-00171/article_deploy/html/images/economies-10-00171-g007-550.jpg](#))([/economies/economies-10-](#)

[00171/article_deploy/html/images/economies-10-00171-g008-550.jpg](#))

Open Access Article

[./2227-7099/10/7/170/pdf?version=1658204005](#)

Internationalization Strategies at a Crossroads: Family Business Market Diffusion in the Post-COVID Era ([/2227-7099/10/7/170](#))

by [Joana Costa](#) (<https://sciprofiles.com/profile/742322>)

Economies 2022, 10(7), 170; <https://doi.org/10.3390/economies10070170> (<https://doi.org/10.3390/economies10070170>) - 18 Jul 2022

Viewed by 322

Abstract COVID-19 is the last nail in the coffin of globalization as we know it. This research aims to explore the influence of capital ownership in the (re)design of internationalization strategies among firms, considering the new macroeconomic challenges. It is commonly accepted that the [...] [Read more](#).

Open Access Article

[./2227-7099/10/7/169/pdf?version=1658123840](#)

The Development of Cognitive and Noncognitive Skills in Students in the Autonomous Province of Trento ([/2227-7099/10/7/169](#))

by [Giorgio Vittadini](#) (<https://sciprofiles.com/profile/1814032>),

[Giuseppe Folloni](#) (<https://sciprofiles.com/profile/author/Q0s0NFILL21xaTB6dXBlaZhmWE5ONHRHcWZNM3JGRig5UmZCR1A0WUxGdz0=>) and

[Caterina Sturaro](#) (<https://sciprofiles.com/profile/2216616>)

Economies 2022, 10(7), 169; <https://doi.org/10.3390/economies10070169> (<https://doi.org/10.3390/economies10070169>) - 15 Jul 2022

Viewed by 290

Abstract The analysis of what human capital (HC) is has a long history and culminates in the acknowledgment that HC and its growth are very important for both cognitive education (cognitive skills (CSs)) and personal life (noncognitive skills (NCSs)) and that CSs and NCSs [...] [Read more](#).

(This article belongs to the Special Issue [Advances in Economics of Education](#) ([/journal/economies/special_issues/Advances_Economics_Education](#)))

Open Access Article

[./2227-7099/10/7/168/pdf?version=1657763035](#)

Managing Food Imports for Food Security in Qatar ([/2227-7099/10/7/168](#))

by [Simeon Kaitibie \(https://sciprofiles.com/profile/2126221\)](https://sciprofiles.com/profile/2126221),
[Patrick Irungu \(https://sciprofiles.com/profile/author/OWJ5VS9uNmXzMGp6V0Vkam5jaWxuaXBvWVRYWUFzQ0I4QW1tQUgpeXBURT0=\)](https://sciprofiles.com/profile/author/OWJ5VS9uNmXzMGp6V0Vkam5jaWxuaXBvWVRYWUFzQ0I4QW1tQUgpeXBURT0=),
[John N. Ng'ombe \(https://sciprofiles.com/profile/247537\)](https://sciprofiles.com/profile/247537) and [Arnold Missiame \(https://sciprofiles.com/profile/2330728\)](https://sciprofiles.com/profile/2330728)
Economies 2022, 10(7), 168; <https://doi.org/10.3390/economies10070168> (<https://doi.org/10.3390/economies10070168>)
Viewed by 448

Abstract Faced with food supply disruptions due in part to geopolitics and political instability in its traditional food source markets in the Kingdom of Saudi Arabia and the United Arab Emirates, Qatar—a wealthy, highly import-dependent open economy—plans to identify a set of alternative markets [...]. [Read more.](#)

Open Access Review  [./2227-7099/10/7/167/pdf?version=1658382705](https://doi.org/10.3390/economies10070167/pdf?version=1658382705)

[Digital Entrepreneurship and Creative Industries in Tourism: A Research Agenda \(./2227-7099/10/7/167\)](https://doi.org/10.3390/economies10070167)

by [Nikolaos Varotsis \(https://sciprofiles.com/profile/2271708\)](https://sciprofiles.com/profile/2271708)
Economies 2022, 10(7), 167; <https://doi.org/10.3390/economies10070167> (<https://doi.org/10.3390/economies10070167>) - 13 Jul 2022
Viewed by 470

Abstract Recently, digital entrepreneurship and creative industries in tourism have been emerging strongly, possibly as a result of the global pandemic of the last two years. Their growth in the last decade has been due to the penetration of technology into the daily life [...]. [Read more.](#)

(This article belongs to the Special Issue [Management Challenges for Business in Digital Economy: New Pathways and Research Trends \(./journal/economies/special_issues/Management_Challenges_Business_Digital_Economy.\)](#))

[► Show Figures](#)

[./economies/economies-10-00167/article_deploy/html/images/economies-10-00167-g001-550.jpg](https://doi.org/10.3390/economies10-00167/article_deploy/html/images/economies-10-00167-g001-550.jpg)

Open Access Feature Paper Article  [./2227-7099/10/7/166/pdf?version=1658121785](https://doi.org/10.3390/economies10070166/pdf?version=1658121785)

[Radial Symmetry Does Not Preclude Condorcet Cycles If Different Voters Weight the Issues Differently \(./2227-7099/10/7/166\)](https://doi.org/10.3390/economies10070166)

by [Richard F. Potthoff \(https://sciprofiles.com/profile/84445\)](https://sciprofiles.com/profile/84445)
Economies 2022, 10(7), 166; <https://doi.org/10.3390/economies10070166> (<https://doi.org/10.3390/economies10070166>) - 13 Jul 2022
Viewed by 321

Abstract Radial symmetry, by our definition, is a precise condition on continuous ideal-point distributions, rarely if ever found exactly in practice, that is similar to the classical 1967 symmetry condition of Plott but pertains to an infinite electorate; the bivariate normal distribution provides an [...]. [Read more.](#)

(This article belongs to the Special Issue [Recent Topics in Economic Research – Feature Papers for Celebrating the 10th Anniversary of Economies \(./journal/economies/special_issues/10th_Anniversary_Economies.\)](#))

[► Show Figures](#)

[./economies/economies-10-00166/article_deploy/html/images/economies-10-00166-g001-550.jpg](https://doi.org/10.3390/economies10-00166/article_deploy/html/images/economies-10-00166-g001-550.jpg)

Open Access Article  [./2227-7099/10/7/165/pdf?version=1657630365](https://doi.org/10.3390/economies10070165/pdf?version=1657630365)

[The Mechanism of an Individual's Internal Process of Work Engagement, Active Learning and Adaptive Performance \(./2227-7099/10/7/165\)](https://doi.org/10.3390/economies10070165)

by [Widya Nandini \(https://sciprofiles.com/profile/2262843\)](https://sciprofiles.com/profile/2262843), [Aurik Gustomo \(https://sciprofiles.com/profile/2325343\)](https://sciprofiles.com/profile/2325343) and
[Dedy Sushandoyo \(https://sciprofiles.com/profile/author/ZHxhEfpQNW5EVkZhaVBXZ0prdlIMEd0Q2xGeDIpcINvdFY4anZBLzVUTT0=\)](https://sciprofiles.com/profile/author/ZHxhEfpQNW5EVkZhaVBXZ0prdlIMEd0Q2xGeDIpcINvdFY4anZBLzVUTT0=)
Economies 2022, 10(7), 165; <https://doi.org/10.3390/economies10070165> (<https://doi.org/10.3390/economies10070165>) - 12 Jul 2022
Viewed by 377

Abstract This paper aims to investigate the mechanism linking an individual's internal processes, work engagement, active learning, and adaptive performance in three of Indonesia's digital technology-based companies. The research uses a mixed-method approach. The first study used a quantitative research method in which the [...]. [Read more.](#)

(This article belongs to the Special Issue [Management Challenges for Business in Digital Economy: New Pathways and Research Trends \(./journal/economies/special_issues/Management_Challenges_Business_Digital_Economy.\)](#))

[► Show Figures](#)

[./economies/economies-10-00165/article_deploy/html/images/economies-10-00165-g001-550.jpg](https://doi.org/10.3390/economies10-00165/article_deploy/html/images/economies-10-00165-g001-550.jpg) [./economies/economies-10-00165/article_deploy/html/images/economies-10-00165-g002-550.jpg](https://doi.org/10.3390/economies10-00165/article_deploy/html/images/economies-10-00165-g002-550.jpg)

Open Access Article  [./2227-7099/10/7/164/pdf?version=1657622935](https://doi.org/10.3390/economies10070164/pdf?version=1657622935)



[Mathematical Modeling of Physical Capital Diffusion Using a Spatial Solow Model: Application to Smuggling in Venezuela \(./2227-7099/10/7/164\)](https://doi.org/10.3390/economies10070164)

by [Gilberto González-Parra \(https://sciprofiles.com/profile/536989\)](https://sciprofiles.com/profile/536989), [Benito Chen-Charpentier \(https://sciprofiles.com/profile/580044\)](https://sciprofiles.com/profile/580044),
[Abraham J. Arenas \(https://sciprofiles.com/profile/1102251\)](https://sciprofiles.com/profile/1102251) and [Miguel Díaz-Rodríguez \(https://sciprofiles.com/profile/424215\)](https://sciprofiles.com/profile/424215)
Economies 2022, 10(7), 164; <https://doi.org/10.3390/economies10070164> (<https://doi.org/10.3390/economies10070164>) - 12 Jul 2022
Viewed by 461

Abstract This study proposes a mathematical modeling approach for the physical capital diffusion through the borders of countries. Physical capital is considered a crucial variable for the economic growth of a nation. Here, we use an extension of the economic Solow model to describe [...]. [Read more.](#)

[► Show Figures](#)

[./economies/economies-10-00164/article_deploy/html/images/economies-10-00164-g001-550.jpg](https://doi.org/10.3390/economies10-00164/article_deploy/html/images/economies-10-00164-g001-550.jpg) [./economies/economies-10-00164/article_deploy/html/images/economies-10-00164-g002-550.jpg](https://doi.org/10.3390/economies10-00164/article_deploy/html/images/economies-10-00164-g002-550.jpg) [./economies/economies-10-00164/article_deploy/html/images/economies-10-00164-g003-550.jpg](https://doi.org/10.3390/economies10-00164/article_deploy/html/images/economies-10-00164-g003-550.jpg) [./economies/economies-10-00164/article_deploy/html/images/economies-10-00164-g004-550.jpg](https://doi.org/10.3390/economies10-00164/article_deploy/html/images/economies-10-00164-g004-550.jpg) [./economies/economies-10-00164/article_deploy/html/images/economies-10-00164-g005-550.jpg](https://doi.org/10.3390/economies10-00164/article_deploy/html/images/economies-10-00164-g005-550.jpg) [./economies/economies-10-00164/article_deploy/html/images/economies-10-00164-g006-550.jpg](https://doi.org/10.3390/economies10-00164/article_deploy/html/images/economies-10-00164-g006-550.jpg)

The Impacts of the Entrepreneurial Conditions on Economic Growth: Evidence from OECD Countries ([/2227-7099/10/7/163](https://doi.org/10.3390/economies10070163)).by [Sofia Gomes](https://sciprofiles.com/profile/1533874) (<https://sciprofiles.com/profile/1533874>), [João Ferreira](https://sciprofiles.com/profile/700401) (<https://sciprofiles.com/profile/700401>), [João Morais Lopes](https://sciprofiles.com/profile/882633) (<https://sciprofiles.com/profile/882633>) and [Luís Farinha](https://sciprofiles.com/profile/1530875) (<https://sciprofiles.com/profile/1530875>)   *Economies* **2022**, *10*(7), 163; <https://doi.org/10.3390/economies10070163> (<https://doi.org/10.3390/economies10070163>) - 12 Jul 2022

Viewed by 347

Abstract This study aims to assess the impacts of entrepreneurial framework conditions on economic growth based on the level of economic development in transition-driven economies and innovation-driven economies. The data were organised into a panel (2000–2019) and obtained from the National Expert Survey (NES), [...] [Read more](#).(This article belongs to the Section **Economic Development, Growth, and Natural Resources (Environment + Agriculture)**)([/journal/economies/sections/economic_development_growth_natural_resources_environment+agriculture](https://journal/economies/sections/economic_development_growth_natural_resources_environment+agriculture)) [Show Figures](#)([/economies/economies-10-00163/article_deploy/html/images/economies-10-00163-g001-550.jpg](https://economies/economies-10-00163/article_deploy/html/images/economies-10-00163-g001-550.jpg)).**Leadership Styles, High-Involvement Human Resource Management Practices, and Individual Employee Performance in Small and Medium Enterprises in the Digital Era** ([/2227-7099/10/7/162](https://doi.org/10.3390/economies10070162)).by [Afriyadi Cahyadi](https://sciprofiles.com/profile/2062589) (<https://sciprofiles.com/profile/2062589>), [Taufiq Marwa](https://sciprofiles.com/profile/author/MIhDSjICN3EvNHM0RVhtKzd3RnBFWIM4TVpGwxRueGJsUTMwOUI5b3g5ST0=) (<https://sciprofiles.com/profile/author/MIhDSjICN3EvNHM0RVhtKzd3RnBFWIM4TVpGwxRueGJsUTMwOUI5b3g5ST0=>), [István Hágén](https://sciprofiles.com/profile/author/L2xIUfPmbWkwdHBiejdES2J5NUlpbnpFNWRETZXWZ09weDV3VzRBSnFyenBxVIZqTnJMU0ptL3hBMV) (<https://sciprofiles.com/profile/author/L2xIUfPmbWkwdHBiejdES2J5NUlpbnpFNWRETZXWZ09weDV3VzRBSnFyenBxVIZqTnJMU0ptL3hBMV>),[Mohammed Nuru Siraj](https://sciprofiles.com/profile/2076152) (<https://sciprofiles.com/profile/2076152>), [Parama Santati](https://sciprofiles.com/profile/2271274) (<https://sciprofiles.com/profile/2271274>),[József Poór](https://sciprofiles.com/profile/1395867) (<https://sciprofiles.com/profile/1395867>) and[Katalin Szabó](https://sciprofiles.com/profile/author/WGY5emVialQ3SUpDNIFudk8zbUNwRytUZjR3NVVEdWpMZkRqaHA5UGdyND0=) (<https://sciprofiles.com/profile/author/WGY5emVialQ3SUpDNIFudk8zbUNwRytUZjR3NVVEdWpMZkRqaHA5UGdyND0=>)*Economies* **2022**, *10*(7), 162; <https://doi.org/10.3390/economies10070162> (<https://doi.org/10.3390/economies10070162>) - 05 Jul 2022

Viewed by 592

Abstract This research investigates the positive relationship between leadership styles, high-involvement human resource management practices, and individual employee performance. In this study, we adopt servant, shared, and empowering leadership to explain leadership styles in the digital era. We propose four hypotheses and design a [...] [Read more](#).(This article belongs to the Special Issue **Management Challenges for Business in Digital Economy: New Pathways and Research Trends** ([/journal/economies/special_issues/Management_Challenges_Business_Digital_Economy](https://journal/economies/special_issues/Management_Challenges_Business_Digital_Economy)))([/journal/economies/special_issues/Management_Challenges_Business_Digital_Economy](https://journal/economies/special_issues/Management_Challenges_Business_Digital_Economy))) [Show Figures](#)([/economies/economies-10-00162/article_deploy/html/images/economies-10-00162-g001-550.jpg](https://economies/economies-10-00162/article_deploy/html/images/economies-10-00162-g001-550.jpg)), ([/economies/economies-10-00162/article_deploy/html/images/economies-10-00162-g002-550.jpg](https://economies/economies-10-00162/article_deploy/html/images/economies-10-00162-g002-550.jpg)).**Development Aid and Export Resilience in Developing Countries: A Reference to Aid for Trade** ([/2227-7099/10/7/161](https://doi.org/10.3390/economies10070161))by [Sèna Kimm Gnanon](https://sciprofiles.com/profile/970722) (<https://sciprofiles.com/profile/970722>)*Economies* **2022**, *10*(7), 161; <https://doi.org/10.3390/economies10070161> (<https://doi.org/10.3390/economies10070161>) - 04 Jul 2022

Viewed by 400

Abstract The COVID-19 pandemic, as with previous major crises, such as the 2008 financial crisis, has had a severe negative impact on international trade flows. The present paper aims to contribute to the debate concerning how to foster resilience against future crises, in terms [...] [Read more](#).(This article belongs to the Special Issue **Foreign Direct Investment and Investment Policy** ([/journal/economies/special_issues/Foreign_Direct_Investment_Investment_Policy](https://journal/economies/special_issues/Foreign_Direct_Investment_Investment_Policy)))([/journal/economies/special_issues/Foreign_Direct_Investment_Investment_Policy](https://journal/economies/special_issues/Foreign_Direct_Investment_Investment_Policy))) [Show Figures](#)([/economies/economies-10-00161/article_deploy/html/images/economies-10-00161-g001-550.jpg](https://economies/economies-10-00161/article_deploy/html/images/economies-10-00161-g001-550.jpg)), ([/economies/economies-10-00161/article_deploy/html/images/economies-10-00161-g002-550.jpg](https://economies/economies-10-00161/article_deploy/html/images/economies-10-00161-g002-550.jpg)), ([/economies/economies-10-00161/article_deploy/html/images/economies-10-00161-g003-550.jpg](https://economies/economies-10-00161/article_deploy/html/images/economies-10-00161-g003-550.jpg)).**The Impact of the National Economic Recovery Program and Digitalization on MSME Resilience during the COVID-19 Pandemic: A Case Study of Bank Rakyat Indonesia** ([/2227-7099/10/7/160](https://doi.org/10.3390/economies10070160))by [Supari Supari](https://sciprofiles.com/profile/author/WnlsaWF1bIEzRFhHaWxqSFNvOXgyMW91cmVoanpIZHpZGV0MTlIK3VBTT0=) (<https://sciprofiles.com/profile/author/WnlsaWF1bIEzRFhHaWxqSFNvOXgyMW91cmVoanpIZHpZGV0MTlIK3VBTT0=>) and[Hendranata Anton](https://sciprofiles.com/profile/2103988) (<https://sciprofiles.com/profile/2103988>)*Economies* **2022**, *10*(7), 160; <https://doi.org/10.3390/economies10070160> (<https://doi.org/10.3390/economies10070160>) - 01 Jul 2022

Viewed by 464





Abstract This study aims to evaluate the impact of the National Economic Recovery Program—Pemulihan Ekonomi Nasional (PEN) and digitalization on micro, small, and medium enterprises' (MSMEs) resilience during the COVID-19 pandemic. This research is based on primary data from a survey of 6009 Bank [...] [Read more](#).(This article belongs to the Topic **Open Innovation and Entrepreneurship** ([/topics/Open_Innovation_Entrepreneurship](https://topics/Open_Innovation_Entrepreneurship))) [Show Figures](#)

[\(economics/economies-10-00160/article_deploy/html/images/economies-10-00160-g001-550.jpg\)](#) [\(economics/economies-10-00160/article_deploy/html/images/economies-10-00160-g002-550.jpg\)](#)

Open Access Article

  [\(2227-7099/10/7/159/pdf?version=1656993453\)](#)

The Impact of the COVID-19 Pandemic on Economic Growth and Monetary Policy: An Analysis from the DSGE Model in Vietnam [\(2227-7099/10/7/159\)](#)

by  [Trung Duc Nguyen](#) (<https://sciprofiles.com/profile/author/M2dQRmJhcGxOV1dwN1JjUnl5bVREQko4NitZV2JIRlpzcGFocnl1QUxWQT0=>),  [Anh Hoang Le](#) (<https://sciprofiles.com/profile/902310>),  [Eleftherios I. Thalassinos](#) (<https://sciprofiles.com/profile/1193082>) and  [Lanh Kim Trieu](#) (<https://sciprofiles.com/profile/2298910>)

Economies 2022, 10(7), 159; <https://doi.org/10.3390/economies10070159> (<https://doi.org/10.3390/economies10070159>) - 01 Jul 2022

Viewed by 471

Abstract Facing the current complicated situation of the COVID-19 pandemic, in addition to medical efforts on disease prevention and treatment, governments of countries also have to come up with solutions to deal with the negative impacts of the pandemic on the economy. This study [...] [Read more.](#)

(This article belongs to the Special Issue [The Impact of COVID-19 on Financial Markets and the Real Economy](#) ([/journal/economies/special_issues/Impact_COVID_19_Financial_Markets_Real_Economy](#).)

[► Show Figures](#)

[\(economics/economies-10-00159/article_deploy/html/images/economies-10-00159-g001-550.jpg\)](#) [\(economics/economies-10-00159/article_deploy/html/images/economies-10-00159-g002-550.jpg\)](#) [\(economics/economies-10-00159/article_deploy/html/images/economies-10-00159-g003-550.jpg\)](#) [\(economics/economies-10-00159/article_deploy/html/images/economies-10-00159-g004-550.jpg\)](#) [\(economics/economies-10-00159/article_deploy/html/images/economies-10-00159-g005-550.jpg\)](#) [\(economics/economies-10-00159/article_deploy/html/images/economies-10-00159-g006-550.jpg\)](#) [\(economics/economies-10-00159/article_deploy/html/images/economies-10-00159-g007-550.jpg\)](#)

Open Access Article

  [\(2227-7099/10/7/158/pdf?version=1657004542\)](#)

The Impact of COVID-19 on Economic Growth of Countries: What Role Has Income Inequality in It? [\(2227-7099/10/7/158\)](#)



by  [Mahieddine Adnan Ghecham](#) (<https://sciprofiles.com/profile/2247649>)

Economies 2022, 10(7), 158; <https://doi.org/10.3390/economies10070158> (<https://doi.org/10.3390/economies10070158>) - 01 Jul 2022

Viewed by 393

Abstract This paper argues that income inequality explains the variation in the economic performance of different countries over the first year of the COVID-19 pandemic. Unlike the conclusions reported by some studies, this study shows that health casualties caused by COVID-19 has had a [...] [Read more.](#)

Open Access Article

  [\(2227-7099/10/7/157/pdf?version=1656668073\)](#)

The Role of Micro Waqf Bank in Women's Micro-Business Empowerment through Islamic Social Finance: Mixed-Method Evidence from Mawaridussalam Indonesia [\(2227-7099/10/7/157\)](#)

by  [Andri Soemitra](#) (<https://sciprofiles.com/profile/2216366>),  [Kusmilawaty](#) (<https://sciprofiles.com/profile/2366911>) and

 [Tri Inda Fadhila Rahma](#) (<https://sciprofiles.com/profile/author/aU14L3ZGS1VIYzZ6SWR0K1RwcFQybnJzWS9PQXVmV1VIQkl6dGFzOHJIT0=>)

Economies 2022, 10(7), 157; <https://doi.org/10.3390/economies10070157> (<https://doi.org/10.3390/economies10070157>) - 01 Jul 2022

Viewed by 518

Abstract This study examined the role of the Micro Waqf Bank in empowering women micro-entrepreneurs. This research used a mixed-method with an explanatory design. Quantitatively, this study examines the effect of the joint responsibility system, financing, and mentoring on the growth of the micro-enterprises [...] [Read more.](#)

[► Show Figures](#)

[\(economics/economies-10-00157/article_deploy/html/images/economies-10-00157-g001-550.jpg\)](#)

Open Access Article

  [\(2227-7099/10/7/156/pdf?version=1656998298\)](#)

Corporate Entrepreneurship and Innovation Performance: The Mediating Effect of Employee Engagement through Leader's Supervision [\(2227-7099/10/7/156\)](#)

by  [Fatma Makhlof Cherif](#) (<https://sciprofiles.com/profile/author/MWZIMm1aVjRHT0x1aFJYYIU2ZWRWNnp4TU5S1c4YnQvckE4TG9tTEItT0=>)

Economies 2022, 10(7), 156; <https://doi.org/10.3390/economies10070156> (<https://doi.org/10.3390/economies10070156>) - 28 Jun 2022

Viewed by 408

Abstract The purpose of this paper was to investigate the mediated moderating effect of employee engagement (EE) by leader's supervision in the effects of corporate entrepreneurship (CE) on innovation performance (IP). The study applied the cross-sectional analysis with our own survey that provided the [...] [Read more.](#)

(This article belongs to the Special Issue [Novel Insights in the Leadership in Business and Economics](#) ([/journal/economies/special_issues/Novel_Insights_Leadership_Business_Economics](#).)

[► Show Figures](#)

[\(economics/economies-10-00156/article_deploy/html/images/economies-10-00156-g001-550.jpg\)](#)

Open Access Article

  [\(2227-7099/10/7/155/pdf?version=1658391644\)](#)

Do Village Allocation Funds Contribute towards Alleviating Hunger among the Local Community (SDG#2)? An Insight from Indonesia [\(2227-7099/10/7/155\)](#)

by  [Elizabeth T. Manurung](#) (<https://sciprofiles.com/profile/author/c1hnZzFvaWJEMkxQQTZnZTJKRWpENnpwRnZQV1FBWU9MUmFQSDV4V21wND0=>),

 [Sylvia F. E. Maratno](#) (<https://sciprofiles.com/profile/2248317>),  [Paulina Permatasari](#) (<https://sciprofiles.com/profile/1661452>),

 [Arif B. Rahman](#) (<https://sciprofiles.com/profile/1898264>),

 [Reifa Qisthi](#) (<https://sciprofiles.com/profile/author/RmxqQVR1VGJ3UCt3ais2SUF2dGJIWXPxa3FZUzhBOTByVzF1ZktRZIZJMD0=>) and

 [Elvy M. Manurung](#) (<https://sciprofiles.com/profile/2200129>)

Abstract Using an exclusive data set from Indonesia in 2018–2020, this study aims to prove whether there is a relationship between the allocation of village funds and the level of hunger in the community. In particular, this study tries to find out whether the [...] [Read more](#).

(This article belongs to the Topic [Sustainable Development and Food Insecurity](#) ([/topics/food](#)))

Show Figures

[\(/economies/economies-10-00155/article_deploy/html/images/economies-10-00155-g001-550.jpg\)](#) [\(/economies/economies-10-00155/article_deploy/html/images/economies-10-00155-g002-550.jpg\)](#) [\(/economies/economies-10-00155/article_deploy/html/images/economies-10-00155-g003-550.jpg\)](#) [\(/economies/economies-10-00155/article_deploy/html/images/economies-10-00155-g004-550.jpg\)](#) [\(/economies/economies-10-00155/article_deploy/html/images/economies-10-00155-g005-550.jpg\)](#) [\(/economies/economies-10-00155/article_deploy/html/images/economies-10-00155-g006-550.jpg\)](#)

Open Access Article

  [\(/2227-7099/10/7/154/pdf?version=1656325312\)](#)

China in Africa: An Examination of the Impact of China's Loans on Growth in Selected African States ([/2227-7099/10/7/154](#))

by  [Courage Mlambo](#) (<https://sciprofiles.com/profile/967844>).

Economies 2022, 10(7), 154; <https://doi.org/10.3390/economies10070154> (<https://doi.org/10.3390/economies10070154>) - 27 Jun 2022

Viewed by 457

Abstract This study sought to test the impact of China's infrastructure investment on economic growth in selected African states. Many comparative studies have shown the positive role that infrastructural loans plays in supporting economic growth. However, for Africa, the role of China's infrastructure projects [...] [Read more](#).

Show Figures

[\(/economies/economies-10-00154/article_deploy/html/images/economies-10-00154-g001-550.jpg\)](#)

Open Access Article

  [\(/2227-7099/10/7/153/pdf?version=1655945400\)](#)

Emerging Challenges in Technical Vocational Education and Training of Pakistan in the Context of CPEC ([/2227-7099/10/7/153](#))

by  [Naila Bano](#) (<https://sciprofiles.com/profile/author/WmJYT0o3NXIKSv0YXREOTQyREE4NmpVcEQ1NVA2eVNHaitGNIITVy82Yz0=>),

 [Siliu Yang](#) (<https://sciprofiles.com/profile/author/ei9VL0hmdU03NstrS05teTIQRU1zbzZvZ2dNMTZtUXVLYzlyYW5ja1h1OD0=>) and

 [Easar Alam](#) (<https://sciprofiles.com/profile/2307758>).

Economies 2022, 10(7), 153; <https://doi.org/10.3390/economies10070153> (<https://doi.org/10.3390/economies10070153>) - 22 Jun 2022

Viewed by 547



Abstract Pakistan is a country with rich natural and human resources. The role of highly skilled people in national development has become enormously vital in the new developmental period, but it is also an irrefutable fact that the gap in highly skilled personnel in [...] [Read more](#).

(This article belongs to the Section [Labour, Health, and Education](#) ([/journal/economies/sections/labour_health_education](#)))

Show Figures

[\(/economies/economies-10-00153/article_deploy/html/images/economies-10-00153-g001-550.jpg\)](#)

Open Access Article

  [\(/2227-7099/10/7/152/pdf?version=1655885435\)](#)

The Influence of an Export Manager on Export Marketing Policies: Evidence from Exporting Olive Oil Companies in Crete ([/2227-7099/10/7/152](#))

by  [Fani Lamprinou](#) (<https://sciprofiles.com/profile/1962976>),  [Anastasios Semos](#) (<https://sciprofiles.com/profile/1524016>),

 [Efthimia Tsakiridou](#) (<https://sciprofiles.com/profile/author/bXdnRHpZUC9QbTRBdHhVmtuQytsYTJtcStsY3FRblpKajZtbjQzNmdCWT0=>), and

 [Panagiota Sergaki](#) (<https://sciprofiles.com/profile/author/SnpCNTc2TVFoRVJSR1IHd1lqd0RaZDhoSDgvRDVReHZMNH02QXNBQUJzYz0=>).

Economies 2022, 10(7), 152; <https://doi.org/10.3390/economies10070152> (<https://doi.org/10.3390/economies10070152>) - 22 Jun 2022

Viewed by 442

Abstract Cretan olive oil is known for its premium quality worldwide. In the post pandemic international environment, the rising demand for olive oil due to its health benefits has generated greater competition amongst traditionally non-producer and producer countries. Olive oil exports affect both the [...] [Read more](#).

(This article belongs to the Section [Economic Development, Growth, and Natural Resources \(Environment + Agriculture\)](#)

([/journal/economies/sections/economic_development_growth_natural_resources_environment+agriculture](#)))

Show Figures

[\(/economies/economies-10-00152/article_deploy/html/images/economies-10-00152-g001-550.jpg\)](#)

Show export options ▾

Displaying articles 1-25

Previous Issue

[Volume 10, June](#) ([/2227-7099/10/6](#))

Next Issue

[Volume 10, August](#) ([/2227-7099/10/8](#))

[Economies](#) ([/journal/economies](#)), ISSN 2227-7099, Published by MDPI [Disclaimer](#)

[RSS](#) ([/rss/journal/economies](#)) [Content Alert](#) ([/journal/economies/toc-alert](#))

Further Information

Article

Leadership Styles, High-Involvement Human Resource Management Practices, and Individual Employee Performance in Small and Medium Enterprises in the Digital Era

Afriyadi Cahyadi ^{1,2,*}, Taufiq Marwa ², István Hágén ¹, Mohammed Nuru Siraj ¹, Parama Santati ², József Poór ^{1,3} and Katalin Szabó ¹

- ¹ Doctoral School of Economics and Regional Sciences, Hungarian University of Agriculture and Life Sciences, H-2100 Gödöllő, Hungary; hagen.istvan.zsombor@uni-mate.hu (I.H.); mohammed.nuru.siraj@phd.uni-mate.hu (M.N.S.); poor.jozsef@uni-mate.hu or poorj@ujs.sk (J.P.); szabo.katalin@uni-mate.hu (K.S.)
- ² Faculty of Economics, Sriwijaya University, Indralaya 30662, Indonesia; taufiqmarwa@unsri.ac.id (T.M.); santati@unsri.ac.id (P.S.)
- ³ Department of Management, Faculty of Economics and Informatics, J. Selye University, UI. Hradná 21, 94501 Komárno, Slovakia
- * Correspondence: cahyadi.afriyadi@phd.uni-mate.hu or afriyadicahyadi@fe.unsri.ac.id



Citation: Cahyadi, Afriyadi, Taufiq Marwa, István Hágén, Mohammed Nuru Siraj, Parama Santati, József Poór, and Katalin Szabó. 2022. Leadership Styles, High-Involvement Human Resource Management Practices, and Individual Employee Performance in Small and Medium Enterprises in the Digital Era.

Economies 10: 162. <https://doi.org/10.3390/economies10070162>

Academic Editors: Renata Korsakienė, Laima Jesevičiūtė-Ufartienė and Neringa Vilkaitė-Vaitonė

Received: 4 May 2022

Accepted: 8 June 2022

Published: 5 July 2022

Publisher's Note: MDPI stays neutral with regard to jurisdictional claims in published maps and institutional affiliations.



Copyright: © 2022 by the authors. Licensee MDPI, Basel, Switzerland. This article is an open access article distributed under the terms and conditions of the Creative Commons Attribution (CC BY) license (<https://creativecommons.org/licenses/by/4.0/>).

Abstract: This research investigates the positive relationship between leadership styles, high-involvement human resource management practices, and individual employee performance. In this study, we adopt servant, shared, and empowering leadership to explain leadership styles in the digital era. We propose four hypotheses and design a research framework to be analyzed. We develop a self-report questionnaire and distribute it online to three hundred targeted respondents, and collect two hundred and seventy-six complete responses from November 2021 to January 2022. This research applies a quantitative method, using structural equation modeling run by SPSS and AMOS. The results reveal well-distributed data, and all the indicators of the three variables are valid and reliable. The use of CFA confirms the indicators' validity and reliability. The GoF analysis ensures that the research model is feasible for SMEs. The hypothesis analysis shows the acceptance of H1 and H3, but the rejection of H2 and H4. Leadership styles positively affect individual employee performance and high-involvement human resource management practices in SMEs operating in Lubuklinggau. High-involvement human resource management is not a mediator of the relationship between leadership styles and individual employee performance.

Keywords: leadership styles; high-involvement human resource management practices; employee performance; small and medium enterprises; digital era

1. Introduction

Economic and social forces have changed the models, strategies, structures, and processes of traditional business (Muafi et al. 2021). The new business opportunities related to these developments reduce international development inequality (Tayibnapis et al. 2018), local use and spatial effects (Mossberger et al. 2022), and encourage uniformity across industries (Reuschke et al. 2022). Leadership and human resource management (HRM) are crucial for companies using digital technology because of the transformation of human capital due to technological development (Grigorescu et al. 2021). Business leaders and HR managers are agents of digital change in the world of work. These leaders must adopt effective styles in their leadership. They must serve, share, and empower their employees. Credibility, competence, communication, coordination, and participation from employees reflect the success of leadership styles in the digital era. At the same time, HR managers must work with an appropriate approach to ensure the high performance of their employees. They need to conduct dialogue-based and open HRM practices (HRMPs)

to ensure acceptance from their employees. HR planning (HRP), training, compensation, and occupational safety and health (OSH) are not separate from digital transformation for companies.

Three leadership styles (LSs) for SMEs that are now emerging in the digital era are based on service from leaders to employees, interaction between leaders and employees, and empowerment from leaders to employees. These styles can be denoted as servant, shared, and empowering leadership. Different leadership styles relate to HRM from different perspectives. When servant, shared, and empowering leadership align with digitization, their relationship with IEP is interesting to study. Leadership styles are related to employee performance (Megawaty et al. 2022), as are HRMPs (Dela Crus and Cabaluna 2022). HRP, training, compensation, and OHS are HRMPs that are important and relevant to study in the digital economy. The basic idea of high-involvement human resource management practices (HIHRMPs) is to increase employees' motivation by developing their knowledge, skills, and abilities directly towards organizational issues (Rubel et al. 2016). HIHRMPs help employees to participate in the creation of attractive practices in companies (Renkema et al. 2021). SMEs need IT skills to prepare their digital businesses and resources (Wiliandri 2020). However, studies on the relationship between LSs, HIHRMPs, and employee performance are difficult to find.

Researchers have investigated servant, shared, and empowering leadership in various contexts, such as the digital economy and in small and medium enterprises (SMEs). For example, we found more than sixteen thousand results when we entered the keywords, "servant leadership, shared leadership, empowering leadership in the digital economy", in Google Scholar in mid-April 2022 (14 April 2022), and more than thirteen thousand results appeared for the keywords, "servant leadership, shared leadership, empowering leadership in SMEs". However, these results were generally studies conducted in a compartmentalized manner, offering no overarching measures to leaders seeking to apply a single leadership style. Research results that combine servant, shared, and empowering leadership are rare in various scientific journal databases, such as Scopus, Web of Science, PubMed, and Crossref, especially for the digital economy and SMEs. Meanwhile, HRMP studies on companies have not led to a viable approach that promotes dialogue and openness in these contexts. They are limited to the investigation of the role of HRM in the digital economy and, vice versa, the role of digitization in HRM.

Information technology (IT) expert Don Tapscott introduced the concept of the digital economy in his book, entitled *The Digital Economy in 1994: Promise and Peril in the Age of Networked Intelligence* (Teiuşan and Deaconu 2021). Subsequently, Nicholas Negroponte reintroduced it from the University of Massachusetts in 1995 (Narmanov 2022). Indonesia has utilized technological developments over the last thirty years to enable all Indonesians to become part of the digital economy in Southeast Asia (Barata 2019). One of the economic effects is the increasing number of SMEs opening in Indonesia (Arief et al. 2021). These businesses drive the Indonesian economy, making up 99.9 percent of the total companies in Indonesia (Haryati et al. 2021). Furthermore, they drive digital change through their pursuit of competitive advantages in the context of sustainable competition (Fachrunnisa et al. 2020) in the era of the Industrial Revolution 4.0, characterized by the application of digital technology, big data, IoT, and robotics technology. The Indonesian government initiated a strategic plan focused on SMEs. Its aims were to encourage their participation in building the national economy, develop a roadmap of e-commerce based on the synchronization of thirty-nine strategic initiatives across eight ministries, establish friendly foreign direct investment policies to attract techno-based investment and strengthen the domestic base of venture capital, facilitate access to funding, enable the digitization of SMEs and the rapid growth of quality start-ups, and adopt pro-innovation policies (Ramli 2020). The large population and the fragmented geography of Indonesia are good reasons for SMEs to adopt e-commerce (Rahayu and Day 2017).

The adoption of digitization varies from using computers or the Internet to modern technologies such as cloud computing or big data. It even involves business models based

on digital products and services, or using elements from Industry 4.0 (Zimmermann 2016). The Internet enables automation and coordination, communication and collaboration, expands trade, creates jobs, and improves access to services (Falentina et al. 2021). Lubuklinggau is a city at the westernmost district level in South Sumatra province, Indonesia. LSs and HIHRMPs for SMEs in this city are interesting to study. Based on data from the Central Bureau of Statistics of Lubuklinggau accessed on 14 April 2022, more than five thousand SMEs were operating in this city in 2020. The economy grew in 2021, with the economic structure comprising construction, wholesale and retail trade, the repair of cars and motorcycles, real estate, manufacturing, transportation, and warehousing industries.

This research aims to identify the positive effects of servant, shared and empowering leadership styles on individual employee performance (IEP) mediated by HIHRMPs. Researchers have widely studied the causal relationship between LSs, HRMPs, and EP. However, it is rare to find research explaining this relationship in the context of the digital economy. Although many studies discuss the relationship between LSs and HRMPs, they are not in the context of the digital economy. When entering the keywords of leadership styles, HRM, and digital economy into Google and Google Scholar in mid-April 2022, we found that many research results focus on leadership and HRM in digitalization. However, they did not relate to each other in this context.

After this introductory section, we describe the relationship between LSs, HIHRMPs, and IEP in the literature review section. We propose four hypotheses regarding this relationship that form the basis of the research framework in this section. The following sections are the Methodology, Results and Discussion, and Conclusions. We describe the data used and the process for collecting them, the types of statistical analysis used, and the research instruments used in the methodology section. We present the Results and Discussion sections separately for a more detailed understanding. Then, we conclude in the context of the digital economy.

2. Literature Review

Amid an economy hit by the COVID-19 crisis, company leaders and managers must think critically to maintain the performance of their employees. Researchers have proven that the main challenges faced by SMEs in the time of COVID-19 include decreased customer purchasing power, restrictions on interaction and working hours, shortages of raw materials, cancellation of orders, cash flow difficulties, and supply chain disruption (Priyono et al. 2020). Of course, this requires effective leadership styles and an effective approach of HRM to realize employee performance.

2.1. LSs and IEP

Enterprise digitization involves the ability to convert existing products into digital variants. This advantage is crucial for today and future competition. Over the past two decades, this has challenged companies of all sizes and ages (Rossato and Castellani 2020). The digital era demands all employees in companies to work with high motivation, productivity, and task performance. These three requirements represent IEP (Leroy et al. 2018; Marescaux et al. 2019; He et al. 2021). LSs and HRMPs have roles in meeting these demands.

Greenleaf, 1970, introduced the concept of servant leadership (Winston 2022). Then, Eva et al., 2019, re-explained its essence (Aboramadan et al. 2022). This leadership emphasizes ethical, spiritual, and communal values. It is a particular style of prosocial leadership (Neubert et al. 2022). It is also service-oriented, knowledge-based, participatory, process-related, ethical, and socially responsible, reducing scandals or conflicts in organizations (Tantri et al. 2022). Servant leaders fulfill the psychological needs of followers through autonomy, relatedness, and competence (Kalttinen and Hakanen 2022). They provide psychological resources to employees to deal with their job (Ruiz-Palomino et al. 2022), place the welfare of their followers above their own (Lv et al. 2022), contribute to overall employee development (Kumar et al. 2022), and engage employees in emotion and spirit

(Uymaz and Arslan 2022). Indeed, servant leaders service their employees individually, increasing credibility, competency, and communication (Russell and Stone 2002).

The idea of shared leadership has historical roots; almost a century ago, Follett suggested in 1924 that one should look not only to the designated leader but also to others on the team for leadership (D’Innocenzo et al. 2021). Then, Gibb introduced this form of leadership in 1954 (Salas-Vallina et al. 2022). Researchers have explained this leadership with different definitions and conceptualizations (Klasmeier and Rowold 2022). They have described that lateral influence among peers, team phenomenon emergence, and influence spreading across team members existing in this leadership type (Zhu et al. 2018). They have also described that while explained in any disciplines, they are still very much in their nascent stage with many theoretical approaches (Scott-Young et al. 2019). The leaders imply that members have the autonomy and discretion to make decisions and carry out actions (Liang et al. 2021) and encourage individuals to step forward to lead others or withdraw to lead others in the situation (Castellano et al. 2021). Contemporary organizational research recognizes shared leadership (Sinha et al. 2021). Indeed, shared leaders service the employee by coordinating with teamwork formally and informally (Song et al. 2020).

Researchers call for empowering leadership that creates a conducive environment that reduces feelings of powerlessness for high individual self-efficacy and control (Rohlfers et al. 2022; Lin et al. 2022). They understand that the historical development of empowering leadership coincides with leaders’ superiority and employee self-esteem (Cheong et al. 2019). Researchers have also proven that this leadership form enables employees to achieve company goals by delegating responsibility, authority, influence, and power from the leaders to them. Indeed, empowering leaders consult with their employees about strategic decisions, employee abilities, and rules and regulations (Naqshbandi et al. 2018).

Recent research results show that servant leadership relates to IEP and affects employee motivation (Tran and Truong 2021), job performance (Alahbabi et al. 2021), and employee performance (Wanta and Augustine 2021; Pratiwi and Nawangsari 2021). This relationship can indirectly occur, for example, servant leadership and task performance are mediated by work engagement (Kaltiainen and Hakanen 2022; Peng and Chen 2021), and servant leadership and job performance by trust and knowledge sharing (Kadariusman and Bunyamin 2021). Shared leadership relates to employee performance (Ahmed et al. 2022; Ali et al. 2018) and individual performance (Humborstad et al. 2014). Indirectly, shared leadership relates to employee task performance and is mediated by employee feedback-seeking behavior (Qian et al. 2018) and employee motivation (Kim et al. 2018). Shared leadership also indirectly relates to adaptive performance through the mediating role of proactive behavior (Fu et al. 2020). Empowering leadership relates directly or indirectly to employee performance (Ali et al. 2018). Empowering leadership relates to employee performance (Kim et al. 2018; Ahmed et al. 2022). Researchers have found a positive relationship between employee psychological empowerment and performance over the last two decades (Shi et al. 2022). Empowering leadership is a specific set of leader behaviors about delegating authority and increasing individual motivation towards their tasks (Cheong et al. 2019). Based on the causal relationship between LSs and IEP, we assume that servant, shared, and empowering leadership improve IEP.

Hypothesis 1 (H1). *Positively, LSs in the scope of the servant, shared, and empowering leadership affect IEP.*

2.2. HIHRMPs and IEP for Sustainability

Researchers have agreed that SHRM includes many practices such as recruitment, training, performance appraisal, career management, and compensation (Da Silva et al. 2020; Alsafadi and Altahat 2021; Shaukat et al. 2015; Tabiu et al. 2016; Manzoor et al. 2019). They have also agreed that HIHRMPs emerge when employees have well-developed skills, the motivation to apply them, and platforms through which to contribute them (Huo

et al. 2015; Leroy et al. 2018). High involvement by employees supports the work of HR managers in realizing sustainability for a company.

The main objective of HRP is to ensure the best level of interaction between employees and their jobs (Gautam and Raj 2018). It is a procedure for anticipating and preparing for the departure of retiring workers and also replacing them with new workers (Ellinger and Svendsen 2021). HRP is one of the leading strategies to improve employee performance through detection (Muma et al. 2018). It is a rational and planned approach to staff recruitment, retention, utilization, and performance (Mansaray 2019). HRP includes obtaining the number of qualified employees and the appropriate employee allocation for improving productivity (Gomathy et al. 2022). Researchers have studied the relationship between recruitment and selection in HRP and employee performance (Al Qudah et al. 2014).

Training is a process relating to employee cognitive disposition to conform to an organization's expectations (John and Dickson 2022). Researchers have explained that it can be a systematic process or a learning experience of acquiring knowledge, skills, abilities, and attitudes and behaviors to meet job requirements (Karim 2019). Training builds original HRs through developing task-related skills and knowledge in education (Sung and Choi 2018). Researchers have explained that training is a business activity, a short-term educational process, and a planning process for developing attitudes, knowledge, or artistic experience through learning to improve performance (Rahayu et al. 2019). It relates to employee performance (Pramono and Prahawan 2022; Handayani and Kasidin 2022; Arwab et al. 2022) and motivation (Tumi et al. 2021). Training increases productivity (Abba 2018).

Compensation is a tool that organizations use to influence employee behavior to increase their contribution and achieve organizational goals (Tumi et al. 2021). It refers to all forms of financial returns, tangible services, and benefits employees receive (Mohammed et al. 2022). Researchers have revealed that compensation refers to basic salaries and additional wages such as overtime pay in meeting needs and salary satisfaction (Widhy et al. 2021). Compensation includes all employee rewards for contributions made to companies (Nguyen et al. 2020) and relates to employee performance (Ramli 2020; Pratibha 2022; Jean et al. 2017).

OSH is an aspect of employee welfare that includes happiness and relationships (De Cieri and Lazarova 2021). The superintelligence revolution, based on the Internet of Things, cyber-physical systems, and artificial intelligence (AI), requires OSH (Min et al. 2019). Occupational health systems in companies also require organizational leaders and managers to take over responsibility (Silva and Amaral 2019). Researchers have found a relationship between OSH and employee well-being (Diaz-Carrion et al. 2019). It is a core responsibility of the HRM (Fan et al. 2020) that impacts on the economy (Mwangi and Waiganjo 2017). Researchers have integrated OSH management and operations management (Hasle et al. 2021). Its implementation creates work safety, reduces accidents (Ilyas et al. 2021), determines work motivation among employees (Nkrumah et al. 2021), and improves employee performance (Ekowati 2019).

Researchers have agreed that employee performance constitutes the quality and quantity of work achieved by an employee in carrying out the responsibilities assigned based on the standards set by the organization (Idris et al. 2022). Achieving a high level of performance through productivity has become the goal for the company (Kazmi and Javaid 2022). Thus, individual performance is appropriate to study in terms of motivation, productivity, and task performance. Employee performance includes high motivation and productivity (Leroy et al. 2018) and task performance (He et al. 2021; Marescaux et al. 2019). Companies will easily achieve their target organizational performance when employees reach the predetermined target. The performance of an organization reflects the performance of the employees who work in it.

Hypothesis 2 (H2). *HIHRMPSs in the scope of HRP, training, compensation, and OSH positively affect IEP.*

2.3. LSs and HIHRMPs

Leadership and HRM can interact when shaping various outcomes (Zhao et al. 2020), for example, they have an impact on employee performance. Indeed, leadership relates to HRMP (Demo et al. 2022). Different leadership styles relate to HRM from different perspectives, for example, green transformational leadership, green HRM (Zhao and Huang 2022), transformational leadership, and HRM practices (Kloutsiniotis et al. 2022; AlAbri et al. 2022). Thus, leadership in serving, sharing, and empowerment can relate to HRMP in the scope of HRP, training, compensation, and OSH. Rotundo and Sackett, 2002, explained that employee performance is a controlled behavior to support organizational goals (Lyubykh et al. 2022).

Hypothesis 3 (H3). *LSs in the scope of servant, shared and empowering leadership positively affect HIHRMPs.*

Hypothesis 4 (H4). *HIHRMPs in the scope of HRP, training, compensation, and OSH mediate the positive relationship between LSs and IEP.*

2.4. Research Framework

Based on the above hypotheses, we describe the research framework as shown in Figure 1. LSs are the independent variable that positively affect IEP and HIHRMPs. HIHRMPs are the mediating variable that positively affect IEP, which is the dependent variable.

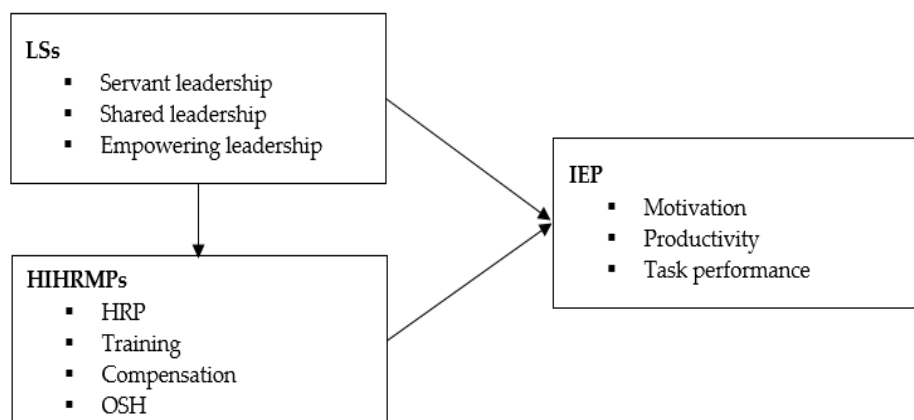

Figure 1. The positive relationship between LSs, HIHRMPs, and IEP.

3. Methodology

This research implements an explanatory approach that explains the relationship between the three variables measured based on existing theories. We measure LSs for the first indicator by service by the leaders in increasing credibility, competence, and communication among their employees. Formal and informal leader coordination with employee work teams indicates the sharing LS. The opportunities provided by leaders to employees to participate in making decisions characterize empowering LSs. We measure HIHRMPs by well-developed skills, motivation, and platforms owned by employees in HRP, training, compensation, and OSH. We measure IEP by motivation, productivity, and the task performance of employees. All measures of these three variables form the basis for developing a self-report questionnaire, as shown in Table 1. It contains six questions for LSs, four questions for HIHRMPs, and three for IEP. We use demographic characteristics consisting of gender, age, formal education, and work experience to describe the respondent's profile, as shown in Table 2.

Table 1. Questionnaire development.

No.	Indicators	Sources
LSs: The chief executive officer of my company . . .		
1	Provides services to me in increasing my credibility and competence in working (servant leadership: X1.1).	(Russell and Stone 2002)
2	Provides services to me in improving communication skills (servant leadership: X1.2).	
3	Interacts formally in the coordination of my teamwork (shared leadership: X1.3).	(Song et al. 2020)
4	Interacts informally in the coordination of my work team (shared leadership: X1.4).	
5	Involves my participation in managerial decision-making (empowering leadership: X1.5).	(Naqshbandi et al. 2018)
6	Makes managerial decisions according to my participation (empowering leadership: X1.6).	
HIHRMPs: I have well-developed skills, motivation, and platform to apply them in . . .		
7	HRP (X2.1).	(Huo et al. 2015; Leroy et al. 2018)
8	Training (X2.2).	
9	Compensation (X2.3).	
10	OSH (X2.4).	
IEP: I have . . .		
11	High motivation at work (Y1).	(Leroy et al. 2018)
12	High productivity at work (Y2).	
13	high performance in completing tasks of work (Y3).	(He et al. 2021; Marescaux et al. 2019)

Table 2. Profile of respondents.

Demography	Percentage (%)
Gender	Female (44.56); Male (55.43)
Age	20–30 years old (23.55); 31–40 years old; (30.07); 41–50 years old (20.28); >50 years old (26.09)
Education	High schools (60); Universities (40)
Work experience	<5 years (26%); 5–10 years (55); >10 years (18.84)

The questionnaire was created online in Google Forms format and distributed to respondents with a target of 300 people. They were employees of SMEs in Lubuklinggau. We used the snowball sampling method by utilizing the social media platforms of WhatsApp and Messenger to distribute the questionnaire to respondents from November 2021 to January 2022. This method was adequate for the development of information technology for the people in the city. We provided a 5-point Likert scale to classify their answers, namely, strongly disagree (1), disagree (2), neutral (3), agree (4), and strongly agree (5). We did not ask for respondents' identities or their companies' identities. The cross-sectional data that we collected came to a total of 276 samples, and was then processed using SPSS and AMOS, which are programs appropriate for covariance-based structural equation modeling (CB-SEM) with more than 200 samples.

4. Results

We tested common method bias (CMB), validity, and reliability before testing and analyzing the data. Based on the results of the CMB, the percentage of the variance was 0.65 or above 0.50. This showed that the data had a CMB, which then needed to be tested for validity and reliability. The calculated R-value of all items was 0.534 to 0.696, higher than the table R-value (DF (N-2) or $276 - 2 = 274$) with a significance level of 0.05, 0.118 (X.1 = 0.677, X.2 = 0.683, X.3 = 0.604, X.4 = 0.644, X.5 = 0.647, X.6 = 1, Y1.1 = 0.618, Y1.2 = 0.601, Y1.3 = 0.534, Y1.4 = 1, Y2.1 = 0.696, Y2.2 = 0.680, Y2.3 = 1). Additionally, the Cronbach alpha of X = 0.93, Y1 = 0.849, and Y2 = 0.869.

We explain these research results in four parts: descriptive analysis, confirmatory factor analysis (CFA), goodness of fit (GoF) analysis, and hypothesis analysis. The first part (Table 3) compares the mean, standard deviation, and variance of all data per indicator. The second part includes construct validity (Table 4), convergent validity and construct reliability (Table 5), average variance, and implied covariance extracted metrics (Table 6). The third part describes the chi-square model (CMIN)/the degrees of freedom (df), the root mean square error of approximation (RMSEA), comparative fit index (CFI), Tucker–Lewis fit index (TLI), incremental fit index (IFI), relative fit index (RFI), normal fit index (NFI), root mean square residual (RMR), and goodness of fit (GFI). The last part shows the direct and indirect relationship between the variables, critical ratio, probability, and decision to accept or reduce the hypotheses.

Table 3. Mean, standard deviation, and variance.

No.	Indicators	N	Minimum	Maximum	Mean	Standard Deviation	Variance
1	X1.1				3.62	1.187	1.408
2	X1.2				3.50	1.165	1.356
3	X1.3				3.58	1.159	1.343
4	X1.4				3.65	1.167	1.362
5	X1.5				3.53	1.155	1.334
6	X1.6				3.72	1.158	1.342
7	Y1.1	276	1	5	3.61	1.121	1.257
8	Y1.2				3.67	1.129	1.275
9	Y1.3				3.67	1.106	1.224
10	Y1.4				3.67	1.106	1.224
11	Y2.1				3.58	1.114	1.241
12	Y2.2				3.69	1.107	1.225
13	Y2.3				3.63	1.182	1.397

Table 4. Construct validity.

No.	Correlation	Estimate	Standard Error	Critical Ratio	Probability
1	X1.1 ← LSs	1.000			
2	X1.2 ← LSs	0.977	0.055	17.776	***
3	X1.3 ← LSs	0.956	0.055	17.254	***
4	X1.4 ← LSs	0.961	0.056	17.218	***
5	X1.5 ← LSs	0.985	0.054	18.227	***
6	X1.6 ← LSs	0.909	0.057	15.944	***

Table 4. *Cont.*

No.	Correlation	Estimate	Standard Error	Critical Ratio	Probability
7	Y1.1 ← HIHRMPs	1.000			
8	Y1.2 ← HIHRMPs	0.928	0.066	13.973	***
9	Y1.3 ← HIHRMPs	0.908	0.065	14.042	***
10	Y1.4 ← HIHRMPs	0.891	0.065	13.700	***
11	Y2.1 ← IEP	1.000			
12	Y2.2 ← IEP	0.948	0.056	16.818	***
13	Y2.3 ← IEP	1.045	0.059	17.688	***

*** means that the probability < 0.001.

Table 5. Convergent validity and reliability.

Correlation	LF	AVE	CR and CA
X1.1 ← LSs	0.843		
X1.2 ← LSs	0.839		
X1.3 ← LSs	0.826	0.62	0.91 (CR) 0.93 (CA)
X1.4 ← LSs	0.824		
X1.5 ← LSs	0.853		
X1.6 ← LSs	0.785		
Y1.1 ← HIHRMPs	0.815		
Y1.2 ← HIHRMPs	0.751	0.53	0.82 (CR) 0.849 (CA)
Y1.3 ← HIHRMPs	0.750		
X2.4 ← HIHRMPs	0.736		
Y2.1 ← IEP	0.847		
Y2.2 ← IEP	0.808	0.63	0.84 (CR) 0.869 (CA)
Y2.3 ← IEP	0.834		

Table 6. Metric implied co-variances.

	Indicators												
	Y2.3	Y2.2	Y2.1	Y1.4	Y1.3	Y1.2	Y1.1	X1.6	X1.5	X1.4	X1.3	X1.2	X1.1
Y2.3	1.392												
Y2.2	0.878	1.220											
Y2.1	0.927	0.841	1.236										
Y1.4	0.782	0.709	0.748	1.220									
Y1.3	0.797	0.723	0.763	0.673	1.220								
Y1.2	0.814	0.738	0.779	0.688	0.701	1.270							
Y1.1	0.877	0.796	0.840	0.741	0.756	0.772	1.253						
X.6	0.890	0.807	0.852	0.715	0.728	0.744	0.802	1.337					
X.5	0.964	0.874	0.923	0.774	0.789	0.806	0.869	0.893	1.329				
X.4	0.941	0.853	0.900	0.755	0.770	0.786	0.848	0.872	0.944	1.357			
X.3	0.936	0.849	0.896	0.752	0.766	0.783	0.844	0.867	0.939	0.917	1.338		
X.2	0.956	0.867	0.915	0.768	0.783	0.799	0.862	0.886	0.960	0.937	0.932	1.351	
X.1	0.978	0.888	0.937	0.786	0.801	0.818	0.882	0.907	0.982	0.958	0.954	0.974	1.403

4.1. Descriptive Analysis

Based on Table 3, from a total of 13 indicators studied based on a sample of 276 (N), the answers from the respondents were spread from 1 (minimum value) to 5 (maximum value) on a 5-point Likert scale. The mean values were between 3.50 and 3.72. They reflected a statement agreeing to all statements in the questionnaire. The standard deviation values were between 1.106 and 1.182, and the variance values were between 1.224 and 1.408. These values were far below the average value, which means that the data were well distributed.

4.2. CFA

Based on Table 4, all estimated values ranged from 0.891 to 1.045. These values were more than 0.7 and well above the standard error (SE) values. This means that all indicators were constructively valid. The critical ratio (CR) values were between 13.700 and 18.227, and all probability values were 0.000. These CR values were well above 2.96, which means that all relationships between the indicators and variables were positive and significant.

Based on Table 5, all loading factor (LF) values were between 0.736 and 0.853 (>0.7). This means that, convergently, all indicators were valid. All average variance extracted (AVE) values were between 0.53 and 0.63 (>0.5). This means that all discriminatory indicators were valid. The construct reliability (CR) values were between 0.82 and 0.91, and the Cronbach Alpha (CA) values were between 0.849 and 0.93. Thus, all indicators were reliable.

Based on Table 6, all metric implied covariance values for each indicator were greater than the values on the left and below:

1. $Y2.3 = 1.392 >$ all values in the lower columns (0.878, etc.);
2. $Y2.2 = 1.220 >$ all values in the left-hand columns (0.878, etc.) and below (0.841, etc.);
3. $Y2.1 = 1.236 >$ all values in the left-hand columns (0.841, etc.) and below (0.784 etc.);
4. $Y1.4 = 1.220 >$ all values in the left-hand columns (0.784, etc.) and below (0.673, etc.);
5. $Y1.3 = 1.220 >$ all values in the left-hand columns (0.673, etc.) and below (0.701 etc.);
6. $Y1.2 = 1.270 >$ all values in the left-hand columns (0.701, etc.) and below (0.772, etc.);
7. $Y1.1 = 1.253 >$ all values in the left-hand columns (0.772, etc.) and below (0.802, etc.);
8. $X.6 = 1.337 >$ all values in the left-hand columns (0.802, etc.) and below (0.893, etc.);
9. $X.5 = 1.329 >$ all values in the left-hand columns (0.893, etc.) and below (0.944, etc.);
10. $X.4 = 1.357 >$ all values in the left-hand columns (0.944, etc.) and below (0.917, etc.);
11. $X.3 = 1.338 >$ all values in the left-hand columns (0.917, etc.) and below (0.932 etc.);
12. $X.2 = 1.351 >$ all values in the left-hand columns (0.932, etc.) and below (0.974 etc.);
13. $X.1 = 1.403 >$ all values in the left-hand columns (0.974, etc.).

4.3. GoF and SEM

The results of the GoF analysis ensured that the research model was feasible to proceed to the hypothesis testing process with SEM. The CMIN value = 87.143 and the degrees of freedom (df) value = 62; thus, the CMIN/df value = 1.406 (<2). RMSEA value = 0.038 (<3); CFI value = 0.991 (>0.9); TLI value = 0.989 (>0.9); IFI value = 0.991 (>0.9); RFI value = 0.963 (>0.9); NFI = 0.971 (>0.9); RMR value = 0.027 (>0.9); and GFI value = 0.953 (>0.9). Figure 2 shows the SEM output of AMOS. The model was recursive with a sample size of 276. The number of different sample moments was 378. The number of variables was 60, with 27 observed variables and 33 unobserved variables. This could also be 31 exogenous variables and 29 endogenous variables.

Figure 2 explains the relationship between the three variables and between the indicators and variables. LSs, the independent variable, affected the two dependent variables, HIHRMPs and IEP. There were seven indicators of SLSs, four indicators of HIHRMPs, and three indicators of IEP. All values of the relationships between SLSs and IEP, HIHRMPs and IEP, SLSs and HIHRMPs were positive. These showed positive relationships.

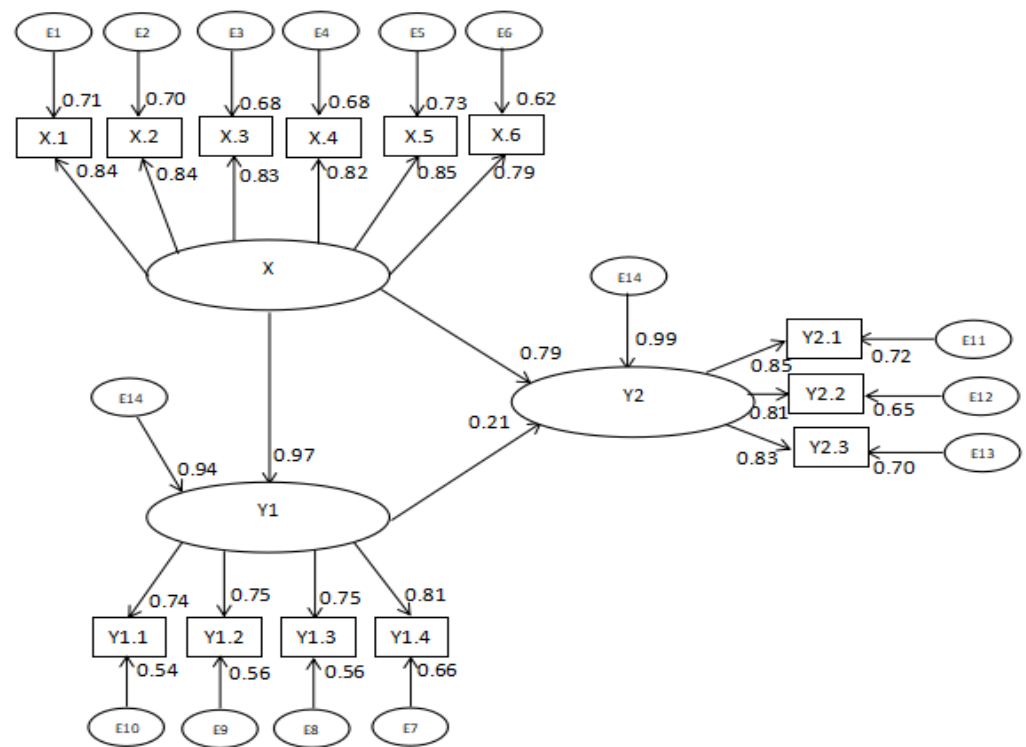

Figure 2. AMOS output in SEM.

4.4. Hypotheses

Table 7 shows two accepted hypotheses, H1 and H3, and two rejected hypotheses, H2 and H4. Thus, LSs significantly positively affected IEP and HIHRMPs. In contrast, HIHRMPs did not affect IEP significantly, and did not mediate the positive relationship between LSs and IEP. Thus, the results did not confirm the model in the research framework. It only provided a direct relationship, not an indirect relationship.

Table 7. Hypotheses.

Direct Effect	Indirect Effect	Total Effect	Critical Ratio	Probability	Decision
H1: LSs → IEP = 0.79	H4: LSs → HIHRMPs → IEP = 0.208	0.996	H1: 3.112	0.02	H1 is accepted, but H4 is rejected.
H2: HIHRMPs → IEP = 0.21		0.21	H2: 0.853	0.394	H2 is rejected.
H3: LSs → HIHRMPs = 0.97		0.97	H3: 16.006	***	H3 is accepted

*** means that the probability < 0.001.

5. Discussion

LSs positively relate to IEP. Employee motivation, productivity, and task performance improve when leaders provide service, sharing, and empowerment to their employees. Additionally, LSs positively relate to HIHRMPs. Employee involvement in HRP, training, compensation, and OSH improves when leaders provide service, sharing, and empowerment to their employees.

5.1. Theoretical Implications

To improve IEP in the digital era, SME employees need support from SME leaders through service, sharing, and empowerment. Employees improve their motivation, pro-

ductivity, and job performance when leaders provide services with credibility, competence, and communication skills. They also achieve high motivation, productivity, and job performance when leaders interact formally and informally in team coordination and involve their employees in making decisions.

To improve HIHRMPs in the digital era, SME HR managers need support from leaders through service, sharing, and empowerment. The involvement of SME employees in HRP, training, compensation, and OSH improves when their leader displays an understanding of their credibility, competence, and communication skills. Employee HIHRMPs also occur when leaders interact formally and informally in team coordination and involve their employees in managerial decision-making.

Thus, LSs have a crucial role in improving IEP and HIHRMPs in the digital era. Embracing digital technology in SMEs requires LSs and HIHRMPs. However, HIHRMPs do not influence IEP, nor do they act as mediators in the relationship between LSs and IEP.

Studies on the servant, shared, and empowering leadership in the digital economy and SMEs are inseparable. Multiple leadership styles are applicable in SMEs. Further researchers can apply a research framework that explains the positive relationship between LSs in servant, shared, and empowering leadership and IEP in terms of motivation, productivity, and task performance.

The positive relationship between LSs and IEP supports the results of research conducted by (Megawaty et al. 2022; Tran and Truong 2021; Alahbabi et al. 2021; Wanta and Augustine 2021; Pratiwi and Nawangsari 2021; Kaltainen and Hakanen 2022; Peng and Chen 2021; Kadarusman and Bunyamin 2021; Ahmed et al. 2022; Ali et al. 2018; Humborstad et al. 2014; Qian et al. 2018; Kim et al. 2018; Fu et al. 2020; Shi et al. 2022; Cheong et al. 2019). The positive relationship between LSs and HIHRMPs strengthens the results of the research conducted by (Demo et al. 2022; Zhao and Huang 2022; Kloutsiniotis et al. 2022; Alabri et al. 2022).

However, the results of this study contradict the results of studies conducted by authors that have explained the interaction between LSs and HIHRMPs in improving IEP. They are (Zhao et al. 2020; Lyubykh et al. 2022; Dela Crus and Cabaluna 2022; Muma et al. 2018; Gomathy et al. 2022; Al Qudah et al. 2014; Rahayu et al. 2019; Pramono and Prahiawan 2022; Handayani and Kasidin 2022; Arwab et al. 2022; Tumi et al. 2021; Abba 2018; Ramli 2020; Pratibha 2022; Jean et al. 2017; Min et al. 2019; Nkrumah et al. 2021; Ekowati 2019).

5.2. Practical Implications

There has been an economic impact due to the increasing number of SMEs opening in Indonesia (Arief et al. 2021). These businesses drive the Indonesian economy and comprise 99.9 percent of the total companies in Indonesia (Haryati et al. 2021). They are the subject of digital change, gaining an advantage by competing sustainably (Fachrunnisa et al. 2020) in the era of the Industrial Revolution 4.0 and applying digital technology, big data, IoT, and robotics technology. The government has initiated a strategic plan focused on SMEs. This is to encourage their participation in building the national economy; develop a roadmap of e-commerce, synchronizing thirty-nine strategic initiatives across eight ministries; establish friendly foreign direct investment policies to attract techno-based investment and strengthen the domestic base of venture capital; facilitate access to funding and enable the digitization of SMEs and the rapid growth of quality start-ups; and adopt pro-innovation policies (Ramli 2020). The large population and the fragmented geography of Indonesia have offered a good reason for SMEs to adopt e-commerce (Rahayu and Day 2017).

The SME leaders in Lubuk Linggau must serve, share, and empower their employees in post-COVID-19 globalization. They must be open to digitization for their employees. They have adopted servant, shared, and empowering leadership. They have applied combined leadership styles, which are not singular or compartmentalized. This is harmonious with the need to be digital leaders in today's digital era. HRM in SMEs comprises high involvement in HRP, training, compensation, and OSH. HRM realizes the importance

of digitalization in the digital demands of business. The employees of the SMEs in the city work with high motivation and productivity, and perform tasks optimally. Their performance is subject to servant, shared, and empowering leadership styles and HIHRMPs.

The practice of servant, shared, and empowering leadership by the CEOs of SMEs in the city, which are generally the owners and managers of the businesses, are relevant for improving IEP and implementing HIHRMPs in today's digital era. These leadership styles support the Indonesian government's strategic plan to build the national economy by strengthening SMEs.

The employees have used computers, the Internet, cloud computing, and big data in adopting business models based on digital products and services. These activities have reflected their involvement in Industry 4.0. They have high motivation, productivity, and job performance due to these leadership styles.

The SME leaders engaged in the construction, wholesale and retail, car and motorcycle repair, real estate, manufacturing, transportation, and warehousing industries in the city have implemented service, sharing, and empowerment LSs for their employees in today's digital era. They support the adoption of digitalization by their employees and the use of services that improve their credibility, competence, and communication skills in working. Leaders also support this by interacting formally and informally in the coordination of employee teamwork, and involving employees in managerial decision-making.

6. Conclusions

Servant, shared, and empowering leadership styles are appropriate to be applied in SMEs to improve the individual performance of employees and employee involvement in HRP, training, compensation, and OSH in the digital era. When SME leaders apply leadership effectively, the individual performance of the employees and their involvement in HRMPs are improved.

SME leaders can apply these leadership styles to realize the high motivation, productivity, and performance of their employees. In addition, leaders can become figures who serve, share, and empower their employees by displaying their involvement in HRPs, training, compensation, and OSH, even though these HRMPs cannot realize the high individual performance of these employees.

The combination of servant, shared, and empowering leadership styles can lead to digital leadership for SMEs. HIHRMPs also clarify digital HRMPs. However, we need further study to state that these leadership styles are digital leadership styles, and HIHRMPs are digital HRMPs.

Limitations

This research framework focuses on the individual performance of employees in SMEs. When high involvement in HRMPs occurs, the teamwork performance of employees can also improve. The concept of LSs in this research frames three leadership styles and one SHRMP approach. Many researchers have examined digital leadership styles in other contexts as measures. This research was limited to one city scope for data collection. Including other cities in Indonesia in this process could offer better results for our proposed hypotheses. We included a two-month primary data collection period. Longer data collections times could show better results with our research framework. We also used an online questionnaire as the research instrument. Direct data collection could possibly reduce bias (CMB) and increase the amount of data collected. The results only showed a direct relationship between the variables, with no indirect relationship or mediation in SEMs. We still have not found that all of our hypotheses are accepted.

Author Contributions: Conceptualization, A.C. and M.N.S.; methodology, A.C. and M.N.S.; software, A.C.; validation, A.C.; formal analysis, A.C. and M.N.S.; investigation, A.C.; resources, A.C.; data curation, A.C.; writing—original draft preparation, A.C. and M.N.S.; writing—review and editing, A.C., T.M., P.S., M.N.S., J.P. and K.S.; supervision, T.M., I.H., J.P. and K.S. All authors have read and agreed to the published version of the manuscript.

Funding: This research received no external funding.

Institutional Review Board Statement: Ethical review and approval were waived for this study due to the fact that we used anonymous data that were not traceable to individuals at any time.

Informed Consent Statement: This was waived for this study due to the fact that we used anonymous data that were not traceable to individuals at any time.

Data Availability Statement: Not applicable.

Conflicts of Interest: The authors declare no conflict of interest.

References

- Abba, Maryam Tijjani. 2018. Effects of Training and Development on Employee Retention in Bauchi State Metropolis Banks. *International Journal of Operational Research in Management* 4: 24–39. Available online: <http://internationalpolicybrief.org/journals/international-scientific-research-consortium-journals/intl-jrnl-of-operational-research-in-mgmt-soc-sci-edu-vol4-no1-june-2018> (accessed on 21 March 2021).
- Aboramadan, Mohammed, Zeeshan Hamid, Yasir Mansoor Kundi, and Eissa El Hamalawi. 2022. The effect of servant leadership on employees' extra-role behaviors in NPOs: The role of work engagement. *Nonprofit Management and Leadership* 1–21. [CrossRef]
- Ahmed, Tanveer, Yang Chaojun, Yang Hongjuan, and Salman Mahmood. 2022. The Impact of Empowering Leadership on Job Performance of Higher Education Institutions Employees: Mediating Role of Goal Clarity and Self-Efficacy. *Psychology Research and Behavior Management* 15: 677–94. [CrossRef] [PubMed]
- Al Qudah, Hamzah Mohammad A., Abdullah Osman, and HamzahEdris M. Al Qudah. 2014. The Effect Of Human Resources Management Practices On Employee Performance. *International Journal of Scientific & Technology Research* 3: 9.
- AlAbri, Ismail, Rusinah Bte Siron, and Mohammad Nurul Alam. 2022. Human Resource Management (HRM) Practices And Employees' Adaptive Performance: The Moderating Role Of Transformational Leadership. *Webology* 19: 2. Available online: <http://www.webology.org> (accessed on 21 March 2022).
- Alahbabi, A. M. F. M., Robani Anidah, and Samer Ali Al-Shami. 2021. A Framework of Servant Leadership Impact on Job Performance: The Mediation Role of Employee Happiness in Uae Healthcare Sector. *Academy of Strategic Management Journal* 20: 1–14.
- Ali, Muhammad, Shen Lei, Zheng Shi Jie, and Mohammad Anisur Rahman. 2018. Empowering leadership and employee performance: A mediating role of thriving at work. *International Journal of Asian Business and Information Management* 9: 1–14. [CrossRef]
- Alsafadi, Yousef, and Shadi Altahat. 2021. Human Resource Management Practices and Employee Performance: The Role of Job Satisfaction. *Journal of Asian Finance, Economics, and Business* 8: 519–29. [CrossRef]
- Arief, Abdul Samad, Petrus Jacob Pattiasina, and Sahat Parulian Remus. 2021. Relevance of human resource management on small business objective in the digital era: A critical review of research evidence. *International Journal of Social Sciences and Humanities* 5: 79–91. [CrossRef]
- Arwab, Mohd, Jamal Abdul Nasir Ansari, Mohd Azhar, and Mohd Ashraf Ali. 2022. Exploring the influence of training and development on employee's performance: Empirical evidence from the Indian tourism industry. *Management Science Letters* 12: 89–100. [CrossRef]
- Barata, Amrin. 2019. Strengthening National Economic Growth and Equitable Income through Sharia Digital Economy in Indonesia. *Journal of Islamic Monetary Economics and Finance* 5: 145–68. [CrossRef]
- Castellano, Sylvaine, Komes Chandavimol, Insaf Khelladi, and Mehmet A. Orhan. 2021. Impact of self-leadership and shared leadership on the performance of virtual r&d teams. *Journal of Business Research* 128: 578–86. [CrossRef]
- Cheong, Minyoung, Francis J. Yammarino, Shelley D. Dionne, Seth M. Spain, and Chou-Yu Tsai. 2019. A review of the effectiveness of empowering leadership. *Leadership Quarterly* 30: 34–58. [CrossRef]
- D'Innocenzo, Lauren, Michael Kukenberger, Andrea C. Farro, and Jennifer A. Griffith. 2021. Shared leadership performance relationship trajectories as a function of team interventions and members' collective personalities. *Leadership Quarterly* 32: 101499. [CrossRef]
- Da Silva, Justino, I. Gede Riana, and Augusto Da Conceicao Soares. 2020. The Effect of Human Resources Management Practices on Innovation and Employee Performance (Study Conducted at NGOs Members of FONGTIL) Dili. *International Journal of Multicultural and Multireligious Understanding* 7: 322–30.
- De Cieri, Helen, and Mila Lazarova. 2021. "Your health and safety is of utmost importance to us": A review of research on the occupational health and safety of international employees. *Human Resource Management Review* 31: 1–30. [CrossRef]
- Dela Crus, Mylene M., and Alan Y. Cabaluna. 2022. Investigating Human Resource Practices and its Impact on Employee Performance in Selected Banks in the Philippines. *Journal of Business and Management Studies*, 233–56.
- Demo, Gisela, Karla Coura, Natasha Fogaça, Ana Carolina Costa, Fernanda Scussel, and Lana Montezano. 2022. How Are Leadership, Virtues, HRM Practices, and Citizenship Related in Organizations? Testing of Mediation Models in the Light of Positive Organizational Studies. *Sustainability* 14: 1508. [CrossRef]
- Diaz-Carrion, Rosalia, Macarena López-Fernández, and Pedro M. Romero-Fernandez. 2019. Evidence of different models of socially responsible HRM in Europe. *Business Ethics* 28: 1–18. [CrossRef]

- Ekowati, Vivin Maharani. 2019. The Effects of Occupational Health and Safety on Employee Performance through Work Satisfaction. *Advances in Economics, Business and Management Research* 101: 242–45. Available online: <http://creativecommons.org/licenses/by-nc/4.0/> (accessed on 21 March 2021).
- Ellinger, Davis Delery, and Schuler Svendsen. 2021. The Impact of Human Resource Planning on Organizational Performance; A Case of Manufacturing Firms in Austria. *Journal of Human Resource & Leadership* 5: 14–21.
- Fachrunnisa, Olivia, Ardian Adhiatma, Najah Lukman, and Md Noh Ab Majid. 2020. Towards SMEs' digital transformation: The role of agile leadership and strategic flexibility. *Journal of Small Business Strategy* 30: 65–85. Available online: <http://www.smallbusinessinstitute.biz> (accessed on 21 March 2021).
- Falentina, Anna T., Budy P. Resosudarmo, Danang Darmawan, and Eny Sulistyningrum. 2021. Digitalisation and the Performance of Micro and Small Enterprises in Yogyakarta, Indonesia. *Bulletin of Indonesian Economic Studies* 57: 343–69. [CrossRef]
- Fan, Di, Cherrie Jiuhua Zhu, Andrew R. Timming, Yiyi Su, Xinli Huang, and Ying Lu. 2020. Using the past to map out the future of occupational health and safety research: Where do we go from here? *International Journal of Human Resource Management* 31: 90–127. [CrossRef]
- Fu, Hui, Ben Haobin Ye, and Xiaoyu Xu. 2020. The cross-level effect of shared leadership on tourism employee proactive behavior and adaptive performance. *Sustainability* 12: 6173. [CrossRef]
- Gautam, Tara Prasad, and Santosh Raj. 2018. Human Resource Planning, Selection and Training Practices of Nepalese Pharmaceutical Companies of Nepal. *Nepal Journal of Multidisciplinary Research (NJMR)* 1: 58–70.
- Gomathy, C. K., K. Varun Reddy, and K. Vikas Reddy. 2022. The Impact of Human Resource Planning on Productivity E-File System. *International Journal of Scientific Research in Engineering and Management* 6: 1–6. [CrossRef]
- Grigorescu, Adriana, Elena Pelinescu, Amalia Elena Ion, and Monica Florica Dutcas. 2021. Human capital in the digital economy: An empirical analysis of central and Eastern European countries from the European Union. *Sustainability* 13: 2020. [CrossRef]
- Handayani, Rini, and Kasidin Kasidin. 2022. Employee Performance Analysis Based on Human Resources Management Practices in Private Hospital in Surakarta. *Kinerja Karyawan Media Ekonomi Dan Manajemen* 37: 109–26. [CrossRef]
- Haryati, Rice, Yasri Yasri, Hasdi Aimon, and Muhammad Darwin. 2021. Development of Small, Micro Enterprises Based (Smes) on Innovation and Environmental Sustainable Development in West Sumatera. *International Journal of Entrepreneurship* 25: 1–13.
- Hasle, Peter, Christian Uhrenholdt Madsen, and David Hansen. 2021. Integrating operations management and occupational health and safety: A necessary part of safety science! *Safety Science* 139: 105247. [CrossRef]
- He, Jie, Alastair M. Morrison, and Hao Zhang. 2021. Being sustainable: The three-way interactive effects of CSR, green human resource management, and responsible leadership on employee green behavior and task performance. *Corporate Social Responsibility and Environmental Management* 28: 1043–54. [CrossRef]
- Humborstad, Sut I. Wong, Christina G. L. Nerstad, and Anders Dysvik. 2014. Empowering leadership, employee goal orientations and work performance: A competing hypothesis approach. *Personnel Review* 43: 246–71. [CrossRef]
- Huo, Baofeng, Zhaojun Han, Haozhe Chen, and Xiande Zhao. 2015. The effect of high-involvement human resource management practices on supply chain integration. *International Journal of Physical Distribution and Logistics Management* 45: 716–46. [CrossRef]
- Idris, Idris, Achmad Suyuti, Ahmad Sani Supriyanto, and Nanang As. 2022. Transformational Leadership, Political Skill, Organizational Culture, and Employee Performance: A Case from Tourism Company in Indonesia. *Geojournal of Tourism and Geosites* 40: 104–10. [CrossRef]
- Ilyas, Muhammad, Aidin Hudani Awasinombu, and Moh Masri. 2021. The Effect of Work Discipline, Teamwork and Occupational Health and Safety on Employee Satisfaction of UPTD Pengelolaan Sampah Dinas Lingkungan Hidup Bombana District. *Journal on Management and Education Human Development* 4: 41–51. Available online: <http://www.ijmehd.com> (accessed on 20 April 2022).
- Jean, Kimani N., Thomas Katua Nguui, and Arasa Robert. 2017. Effect of Compensation Strategies on Employee Performance: A Case Study of Mombasa Cement Limited. *International Journal of Innovative Social Sciences & Humanities Research* 5: 25–42. Available online: www.seahipaj.org (accessed on 21 April 2022).
- John, Achanya Julius, and Cinjel Nandes Dickson. 2022. Employee Training and Employee Development in an Organization: Explaining the Difference for the Avoidance of Research Pitfalls. *Public Administration: Theory and Practice in Nigeria*.
- Kadarusman, Kadarusman, and Benjamin Bunyamin. 2021. The role of knowledge sharing, and trust as mediation on servant leadership and job performance. *Management Science Letters* 11: 1509–20. [CrossRef]
- Kaltainen, Janne, and Jari Hakanen. 2022. Fostering task and adaptive performance through employee well-being: The role of servant leadership. *BRQ Business Research Quarterly* 25: 28–43. [CrossRef]
- Karim, Al Rashed. 2019. Impact of Different Training and Development Programs on Employee Performance in Bangladesh Perspective. *International Journal of Entrepreneurial Research* 1: 8–14. [CrossRef]
- Kazmi, Syeda Wajiha, and Syeda Tuba Javaid. 2022. Antecedents of organizational identification: Implications for employee performance. *RAUSP Management Journal* 57: 111–30. [CrossRef]
- Kim, Minseo, Terry A. Beehr, and Matthew S. Prewett. 2018. Employee Responses to Empowering Leadership: A Meta-Analysis. *Journal of Leadership and Organizational Studies* 25: 257–76. [CrossRef]
- Klasmeier, Kai N., and Jens Rowold. 2022. A diary study on shared leadership, teamwork engagement, and goal attainment. *Journal of Occupational and Organizational Psychology* 95: 36–59. [CrossRef]

- Kloutsiniotis, Panagiotis V., Dimitrios M. Mihail, Naoum Mylonas, and Adamantia Pateli. 2022. Transformational Leadership, HRM practices and burnout during the COVID-19 pandemic: The role of personal stress, anxiety, and workplace loneliness. *International Journal of Hospitality Management* 102: 103177. [CrossRef]
- Kumar, Aneel, Tayabba Gul Pathan, and Hira Rani Shaikh. 2022. Servant Leadership as Impetus for Teachers' Organisational Citizenship and In-role Behaviours: The Mediation of Felt Obligation. *International Journal of Organizational Leadership* 11: 44–54. Available online: <https://www.ijol.cikd.ca> (accessed on 19 April 2022). [CrossRef]
- Leroy, Hannes, Jesse Segers, Dirk Van Dierendonck, and Deanne Den Hartog. 2018. Managing people in organizations: Integrating the study of HRM and leadership. *Human Resource Management Review* 28: 249–57. [CrossRef]
- Liang, Bingqian, Daan van Knippenberg, and Qinxuan Gu. 2021. A cross-level model of shared leadership, meaning, and individual creativity. *Journal of Organizational Behavior* 42: 68–83. [CrossRef]
- Lin, Meizhen, Xiujuan Zhang, Boon Ching Serene Ng, and Lirong Zhong. 2022. The dual influences of team cooperative and competitive orientations on the relationship between empowering leadership and team innovative behaviors. *International Journal of Hospitality Management* 102: 103160. [CrossRef]
- Lv, Wan Qing, Li Chao Shen, Chin-Hsun Ken Tsai, Ching-Hui Joan Su, Hyun Jeong Kim, and Ming-Hsiang Chen. 2022. Servant leadership elevates supervisor-subordinate guanxi: An investigation of psychological safety and organizational identification. *International Journal of Hospitality Management* 101: 103114. [CrossRef]
- Lyubych, Zhanna, Jennifer Bozeman, M. Sandy Hershcovis, Nick Turner, and J. Valerie Shan. 2022. Employee performance and abusive supervision: The role of supervisor over-attributions. *Journal of Organizational Behavior* 43: 125–45. [CrossRef]
- Mansaray, Hasan Elsan. 2019. The Consequence of Human Resource Planning on Organizational Performance: An Ephemeral Review. *Britain International of Humanities and Social Sciences (BloHS) Journal* 1: 50–61. [CrossRef]
- Manzoor, Faiza, Longbao Wei, Tamás Bányai, Mohammad Nurunnabi, and Qazi Abdul Subhan. 2019. An examination of sustainable HRM practices on job performance: An application of training as a moderator. *Sustainability* 11: 2663. [CrossRef]
- Marescaux, Elise, Sophie De Winne, and Anneleen Forrier. 2019. Developmental HRM, employee well-being and performance: The moderating role of developing leadership. *European Management Review* 16: 317–31. [CrossRef]
- Megawaty, M., Aminuddin Hamdat, and Nur Aida. 2022. Examining Linkage Leadership Style, Employee Commitment, Work Motivation, Work Climate on Satisfaction and Performance. *Golden Ratio of Human Resource Management* 2: 1–14. [CrossRef]
- Min, Jeehee, Yangwoo Kim, Sujin Lee, Tae-Won Jang, Inah Kim, and Jaechul Song. 2019. The Fourth Industrial Revolution and Its Impact on Occupational Health and Safety, Worker's Compensation and Labor Conditions. *Safety and Health at Work* 10: 400–8. [CrossRef] [PubMed]
- Mohammed, Ali Ibrahim, Zainab Fadhil Mohammed, and Harith Adnan Mohammad. 2022. The Effect of Compensation Management on Employee Performance: An Empirical Study in North Gas Company. *World Bulletin of Management and Law (WBML)* 7: 59–70. Available online: <https://www.scholarexpress.net> (accessed on 21 April 2022).
- Mossberger, Karen, Scott LaCombe, and Caroline J. Tolbert. 2022. A new measure of digital economic activity and its impact on local opportunity. *Telecommunications Policy* 46: 102231. [CrossRef]
- Muafi, Muafi, Wirman Syafri, Hadi Prabowo, and Sofyan Ashari Nur. 2021. Digital Entrepreneurship in Indonesia: A Human Capital Perspective. *Journal of Asian Finance, Economics, and Business* 8: 351–59. [CrossRef]
- Muma, Michael Mboya, Joyce Nzulwa, Kepha Ombui, and Romanus Odhiambo. 2018. Influence of Human Resource Planning Strategies on Retention of Employees in Universities in Kenya. *International Journal of Thesis Projects and Dissertations (IJTPD)* 6: 1–14. Available online: www.researchpublish.com (accessed on 20 April 2022).
- Mwangi, Jane Walth Ira, and Esther Waiganjo. 2017. Influence of Occupational Health and Safety on Limited, Thika Sub-County. *Strategic Journal* 4: 191–208. Available online: www.strategicjournals.com (accessed on 20 April 2022).
- Naqshbandi, M. Muzamil, Ibrahim Tabche, and Neetu Choudhary. 2018. Managing open innovation: The roles of empowering leadership and employee involvement climate. *Management Decision* 57: 703–23. [CrossRef]
- Narmanov, Ulugbek. 2022. The role and importance of the digital economy in the development of innovation. *Linguistics and Culture Review* 6: 121–33. [CrossRef]
- Neubert, Mitchell J., Mary Sully de Luque, Matthew J. Quade, and Emily M. Hunter. 2022. Servant leadership across the globe: Assessing universal and culturally contingent relevance in organizational contexts. *Journal of World Business* 57: 2. [CrossRef]
- Nguyen, Phong Thanh, Andri Yandi, and M. Rizky Mahaputra. 2020. Factors that Influence Employee Performance: Motivation, Leadership, Environment, Culture Organization, Work Achievement, Competence, and Compensation (A Study of Human Resource Management Literature Studies). *Dinasty international Journal of Digital Business Management* 1: 4. [CrossRef]
- Nkrumah, Edmund Nana Kwame, Suxia Liu, David Doe Fiergbor, and Linda Serwah Akoto. 2021. Improving the safety–performance nexus: A study on the moderating and mediating influence of work motivation in the causal link between occupational health and safety management (ohms) practices and work performance in the oil and gas sector. *International Journal of Environmental Research and Public Health* 18: 5064. [CrossRef] [PubMed]
- Peng, Jui-Chen, and Shou-Wei Chen. 2021. Servant Leadership and Service Performance: A Multilevel Mediation Model. *Psychological Reports* 124: 1738–60. [CrossRef]
- Pramono, Abdul Chatim, and Wawan Prahawan. 2022. Effect of Training on Employee Performance with Competence and Commitment as Intervening. *APTISI Transactions on Management (ATM)* 6: 142–50. [CrossRef]

- Pratibha, S. 2022. HRM Practices on Employee Performance concerning Small-scale industries. *Journal of Positive School Psychology* 6: 915–20. Available online: <http://journalppw.com> (accessed on 20 April 2022).
- Pratiwi, Lintang Arum, and Lenny Christina Nawangsari. 2021. Organizational Citizenship Behavior while mediating Self-Efficacy, Servant Leadership and Organization Culture on Employee Performance. *European Journal of Business and Management Research* 6: 225–31. [CrossRef]
- Priyono, Anjar, Abdul Moin, and Vera Nur Aini Oktaviani Putri. 2020. Identifying Digital Transformation Paths in the Business Model of SMEs during the COVID-19 Pandemic. *Journal of Open Innovation: Technology, Market, and Complexity* 6: 104. [CrossRef]
- Qian, Jing, Baihe Song, Zhuyun Jin, Bin Wang, and Hao Chen. 2018. Linking empowering leadership to task performance, taking charge, and voice: The mediating role of feedback-seeking. *Frontiers in Psychology* 9: 2025. [CrossRef]
- Rahayu, Rita, and John Day. 2017. E-commerce adoption by SMEs in developing countries: Evidence from Indonesia. *Eurasian Business Review* 7: 25–41. [CrossRef]
- Rahayu, Mieke, Fahmi Rasid, and Hendy Tannady. 2019. International Review of Management and Marketing The Effect of Career Training and Development on Job Satisfaction and its Implications for the Organizational Commitment of Regional Secretariat (SETDA) Employees of Jambi Provincial Government. *International Review of Management and Marketing* 9: 79–89. [CrossRef]
- Ramli, Kalamullah. 2020. Indonesia on the Move: Improving Connectivity to Support E-commerce. In *E-commerce Connectivity in ASEAN*. Edited by L. Chen and F. Kimura. Jakarta: Economic Research Institute for ASEAN and East Asia, pp. 31–50.
- Renkema, Maarten, Jan de Leede, and Llewellyn E. Van Zyl. 2021. High-involvement HRM and innovative behavior: The mediating roles of nursing staff's autonomy and affective commitment. *Journal of Nursing Management* 29: 2499–514. [CrossRef]
- Reuschke, Darja, Colin Mason, and Stephen Syrett. 2022. Digital futures of small businesses and entrepreneurial opportunity. *Futures* 128: 102877. [CrossRef]
- Rohlfser, Sylvia, Abderrahman Hassi, and Simon Jebsen. 2022. Management Innovation and Middle Managers: The Role of Empowering Leadership, Voice, and Collectivist Orientation. *Management and Organization Review* 18: 108–30. [CrossRef]
- Rossato, Chiara, and Paola Castellani. 2020. The contribution of digitalization to business longevity from a competitiveness perspective. *TQM Journal* 32: 617–45. [CrossRef]
- Rubel, Mohammad Rabiul Basher, Daisy Mui Hung Kee, Nadia Newaz Rimi, and Yusliza Mohd Yusoff. 2016. Adapting technology: Effect of high-involvement HRM and organizational trust. *Behavior and Information Technology* 36: 281–93. [CrossRef]
- Ruiz-Palomino, Pablo, Benito Yáñez-Araque, Pedro Jiménez-Estévez, and Santiago Gutiérrez-Broncano. 2022. Can servant leadership prevent hotel employee depression during the COVID-19 pandemic? A mediating and multigroup analysis. *Technological Forecasting and Social Change* 174: 121192. [CrossRef] [PubMed]
- Russell, Robert F., and A. Gregory Stone. 2002. A review of servant leadership attributes: Developing a practical model. *Leadership & Organization Development Journal* 23: 145–57. [CrossRef]
- Salas-Vallina, Andrés, Yasin Rofcanin, and Mireia Las Heras. 2022. Building resilience and performance in turbulent times: The influence of shared leadership and passion at work across levels. *BRQ Business Research Quarterly* 25: 8–27. [CrossRef]
- Scott-Young, Christina M., Maged Georgy, and Andrew Grisinger. 2019. Shared leadership in project teams: An integrative multi-level conceptual model and research agenda. *International Journal of Project Management* 37: 565–81. [CrossRef]
- Shaukat, Hafsa, Namrah Ashraf, and Shahzad Ghafoor. 2015. Impact of Human Resource Management Practices on Employees Performance. *Middle-East Journal of Scientific Research* 23: 329–38. [CrossRef]
- Shi, Renmin, Qian Meng, and Jie Huang. 2022. Impact of psychological empowerment on job performance of Chinese university faculty members: A cross-sectional study. *Social Behavior and Personality: An International Journal* 5: 1–11. [CrossRef]
- Silva, Sabrina Leticia Couto da, and Fernando Gonçalves Amaral. 2019. Critical factors of success and barriers to the implementation of occupational health and safety management systems: A systematic review of literature. *Safety Science* 117: 123–32. [CrossRef]
- Sinha, Ruchi, Chia-Yen Chiu, and Santosh B. Srinivas. 2021. Shared leadership and relationship conflict in teams: The moderating role of team power base diversity. *Journal of Organizational Behavior* 42: 649–67. [CrossRef]
- Song, Zhigang, Qinxuan Gu, and Fang Lee Cooke. 2020. The effects of high-involvement work systems and shared leadership on team creativity: A multilevel investigation. *Human Resource Management* 59: 201–13. [CrossRef]
- Sung, Sun Young, and Jin Nam Choi. 2018. Effects of training and development on employee outcomes and firm innovative performance: Moderating roles of voluntary participation and evaluation. *Human Resource Management* 57: 1339–53. [CrossRef]
- Tabiu, Abubakar, Faizuniah Pangil, and Siti Zubaidah Othman. 2016. Examining the link between HRM Practices and Employees' performance in the Nigerian public sector. *Management Science Letters* 6: 395–408. [CrossRef]
- Tantri, Sakina Nusarifa, Shine Pintor Siolemba Patiro, Hendrian Hendrian, and Lasando Lumban Gaol. 2022. The Role of Job Demands in Moderating the Relationship between Servant Leadership and Job Satisfaction: A Study on Civil Apparatus in Five Major Cities in Indonesia. *Jurnal Ilmiah Akuntansi* 6: 221. [CrossRef]
- Tayibnapis, Ahmad Zafrullah, Lucia Endang Wuryaningsih, and Radita Gora. 2018. The Development of Digital Economy in Indonesia. *International Journal of Management and Business Studies (IJMBS)* 8: 14–18.
- Teiușan, Sorin-Ciprian, and Sorin-Constantin Deaconu. 2021. A Bibliometric Analysis for Global Research Trends on Digital Economy. *Revista Economica* 73: 312–36.
- Tran, Toan Khanh Pham, and Truc Trung Truong. 2021. Impact of Servant Leadership on Public Service Motivation of Civil Servants: Empirical Evidence from Vietnam. *Journal of Asian Finance, Economics, and Business* 8: 1057–66. [CrossRef]

- Tumi, Najameddin Sadeg, Ali Nawari Hasan, and Jamshed Khalid. 2021. Impact of Compensation, Job Enrichment, and Enlargement, and Training on Employee Motivation. *Business Perspectives and Research* 10: 121–39. [CrossRef]
- Uymaz, Ali Osman, and Serdar Arslan. 2022. Unethical pro-organizational behavior as an outcome of servant leadership. *Journal of Management and Organization* 28: 33–57. [CrossRef]
- Wanta, Derry, and Yvonne Augustine. 2021. The Effect of Servant Leadership, Job Satisfaction, and Organizational Culture on Employee Performance Moderated by Good Governance in Women’s Cooperative Institution. *Technium Sustainability* 1: 45–58. Available online: www.techniumscience.com (accessed on 16 April 2022).
- Widhy, Sudirman, Hendro Yuliantoro, Muhammad Zulkarnain Anwar, and Anita Maharani. 2021. The Influence of Organizational Culture and Compensation on Organizational Commitment with Job Satisfaction as Mediation. *The Management Journal of Binaniaga* 6: 165–90. [CrossRef]
- Wiliandri, Ruly. 2020. A Conceptual Approach to Identify Factors Affecting the Digital Transformation of Micro, Small, and Medium-sized Enterprises (MSMEs) during the COVID-19 Pandemic in Indonesia. *Ekonomi Bisnis* 25: 66. [CrossRef]
- Winston, Bruce E. 2022. The Relationship of Servant Leadership, Perceived Organizational Support, and Work-family Conflict with Employee Well-being. *Servant Leadership: Theory & Practice* 9: 13–40.
- Zhao, Wei, and Lihua Huang. 2022. The impact of green transformational leadership, green HRM, green innovation and organizational support on the sustainable business performance: Evidence from China. *Economic Research-Ekonomska Istrazivanja* 1–21. [CrossRef]
- Zhao, Shuming, Mingwei Liu, Cherrie J. Zhu, and Hong Liu. 2020. The role of leadership in human resource management: Perspectives and evidence from the Asia Pacific. *Asia Pacific Business Review*, 1–5. [CrossRef]
- Zhu, Jinlong, Zhenyu Liao, Kai Chi Yam, and Russell E. Johnson. 2018. Shared leadership: A state-of-the-art review and future research agenda. *Journal of Organizational Behavior* 39: 834–52. [CrossRef]
- Zimmermann, Volker. 2016. SMEs and digitalization: The current position, recent developments, and challenges. *KfW Research Focus on Economics* 138: 1–7.