

Performance of Bacillus Subtilis bacteria to natural improvement process on rigid pavement cracks

Leni Suwaini, Joni Arliansyah, and Saloma

Citation: *AIP Conference Proceedings* **2030**, 020038 (2018); doi: 10.1063/1.5066679

View online: <https://doi.org/10.1063/1.5066679>

View Table of Contents: <http://aip.scitation.org/toc/apc/2030/1>

Published by the *American Institute of Physics*

AIP | Conference Proceedings

Get **30% off** all
print proceedings!

Enter Promotion Code **PDF30** at checkout



Performance of Bacillus Subtilis Bacteria to Natural Improvement Process on Rigid Pavement Cracks

Leni Suwaini^{1,b)}, Joni Arliansyah^{1,a)}, Saloma^{1,c)}

¹*Department of Civil Engineering of Faculty of Engineering of Sriwijaya University, Palembang, Indonesia*

^{a)}Corresponding author: joniarliansyah@yahoo.com

^{b)}lenisuwaini@gmail.com

^{c)}saloma_571@yahoo.co.id

Abstract. Cracks in a rigid pavement are the main cause of water entry into the structure. Method of repair cracks in the rigid pavement can be done in various ways, one is with the addition of Bacillus Subtillis Bacteria. Bacillus Subtillis is a bacteria that lives on the ground that has been separated in the laboratory. The purpose of this study is to find out how much influence in the addition of bacteria in a particular composition to a rigid pavement to repair cracks and analyze the most effective methods used to accelerate the process of repair cracks in a rigid pavement. The bacterial composition used was 10^4 Cells/mL of water, 10^5 Cells/ml of water and 10^6 Cells/ml of water, with the addition of medium peptone, NaCl and yeast extract mixed on the mortar test sample. The results showed a variety of variations, but the majority of the composition of 10^5 Cells/ml of water was the most effective composition improved, the crack improvement reached 93.33% on crack with dimension of 0.5 mm width and 3 cm depth at 60-day mortar age.

INTRODUCTION

Rigid pavement has more advantages over the use of flexible pavement, one advantage is lower the maintenance costs. With the main material that uses concrete, the rigid pavement has a high compressive strength and has a high-temperature resistance. The weakness in the rigid pavement is the emergence of cracks on the surface, either due to the process of implementation, basic soil conditions or structural worn out factors. One method to repair the crack is by filling a certain mixture with the purpose of preventing water from entering the structure.

The repair of the crack in a rigid pavement can be done naturally by mixing the bacteria into a concrete material. The addition of bacteria as a medium that can produce calcium carbonate is expected to overcome the crack without having to make continuous improvement. This research is to find out whether Bacillus Subtillis Bacteria can fill the empty volume of the cracks in a rigid pavement.

This study aims to analyze the most effective methods that can be used to accelerate the repair process on cracking and to know the optimum composition of bacteria added to the mortar mixture to repair the crack.

The process of natural improvement using bacteria has been done by many researchers, among others, Bacillus Pasteurii Bacteria, Bacillus Cereus Bacteria, Shewanella sp Bacteria, Bacillus Flexus Bacteria, Bacillus Subtillis Bacteria, Bacillus Sphaericus Bacteria, Pseudofirmus Bacteria and Bacillus Cohni Bacteria.

In a study using Bacillus Pasteurii Bacteria and Bacillus Cereus Bacteria showed that bacteria can increase compressive strength in concrete by 29% and tensile strength test can increase up to 38%. The calcium carbonate

produced by bacteria has filled the empty volume on the concrete so that it inhibits the entry of water. Maximum bacteria performance occurs in the concrete cracks which are not deep. [1]. The calcium carbonate produced by bacteria has filled the empty volume on the concrete so that it inhibits the entry of water.

One research by using *Shewanella* sp. Bacteria can increase mortar compressive strength at 28 days of age by 18% compared with no bacteria [2].

Another Research on *Bacillus Flexus* Bacteria was performed by measuring the compressive strength test on a mortar and immersing the test samples with water mixed with bacteria for 7,14 and 28 days, the mortar compressive strength increases up to 18% compared to the bacterialess mortar [3].

Another Study of concrete with *Bacillus Subtillis* Bacteria FNCC 0058 encapsulated with CMC and coated with Sc acrylic resin found that the maximum load of bending strength is less than concrete without mixture with a difference of 12,7%, in Scanning Electron Microscopy (SEM) research; bacteria can improve but not significantly filled the empty volume of the crack [5].

Research using *Bacillus Subtillus* JC3 Bacteria found that water permeability was low on bacteria mixed concrete compared to normal concrete, bacteria can produce calcium carbonate crystals and enter to concrete cracks and pores so that concrete becomes impermeable. *Bacillus Subtillus* JC3 Bacteria with the composition of 100,000 cells/ml of water can increase the compressive strength of concrete almost 23% at 28 days age and *Bacillus Subtillis* JC3 Bacteria is safe to use in concrete structures [6].

Bacillus Cohni Bacteria and *Bacillus Pseudofirmus* Bacteria were used in testing of compressive strength, flexural strength test and Scanning Electron Microscopy (SEM) test. From this research, it was found that concrete compressive strength increased up to 10% compared to concrete without bacteria and bacteria can help to repair cracks in concrete with the crack width is less than 0.2 mm [4].

RESPONSE SURFACE METHODOLOGY

The test samples are mortar with bacteria mixing and mortar without bacteria mixing, Figure 1 shows a flowchart of the steps to be performed.

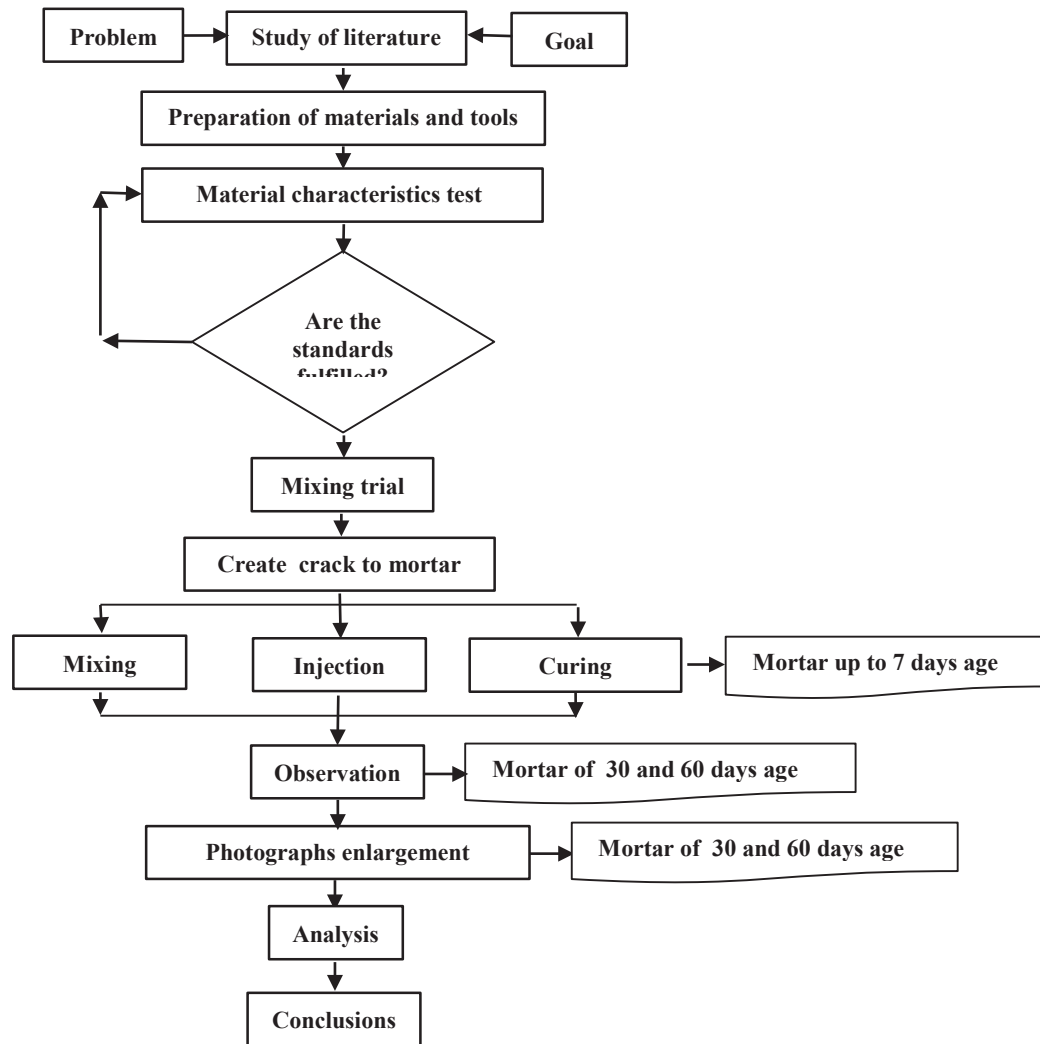

FIGURE 1. Flow Chart of Research

There are three methods used in this research; they are mixing method, injection method and treatment method. Mixing method uses mortar that already contains bacteria. In the curing method, the process is carried out by spraying bacteria mixed water; immediately after the molding process on the mortar without the mixture of bacteria; for 7 days, to maintain the humidity and temperature conditions on the mortar surface and to insert the bacteria in the crack gap as well. In the injection method is the process is carried out by injecting the bacteria into the cracks of the bacterialess mortar, immediately after the molding process of the mortar.

Design of Experiment Setup

In this study, the calculation of the concrete mix using ASTM C 190 with the composition of the mortar mix is showed in Table 1.

TABLE 1. The composition of mortar mixture for 12 pieces of mortar

Number of bacteria (Million)	Cement (gram)	Sand (gram)	Water (ml)
5,14	1.060	2.915	514
51,4	1.060	2.915	514
514	1.060	2.915	514

The test samples were mortar with bacteria mixing and mortar without bacteria mixing, then the test samples were cracked. The crack was as Figure 2, Figure 3, Figure 4.

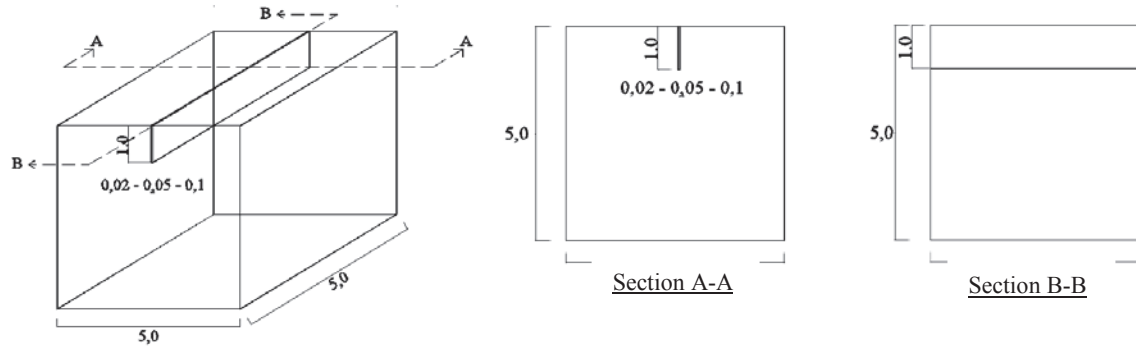

FIGURE 2. Artificial cracks in the test sample with 1 cm depth and 0.2,0.5 and 1 mm width

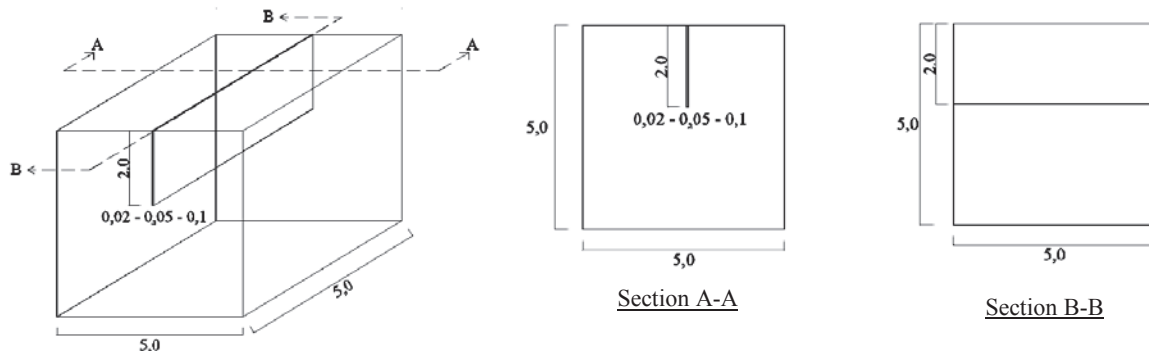

FIGURE 3. Artificial cracks in the test sample with 2 cm depth and 0.2, 0.5 and 1 mm width

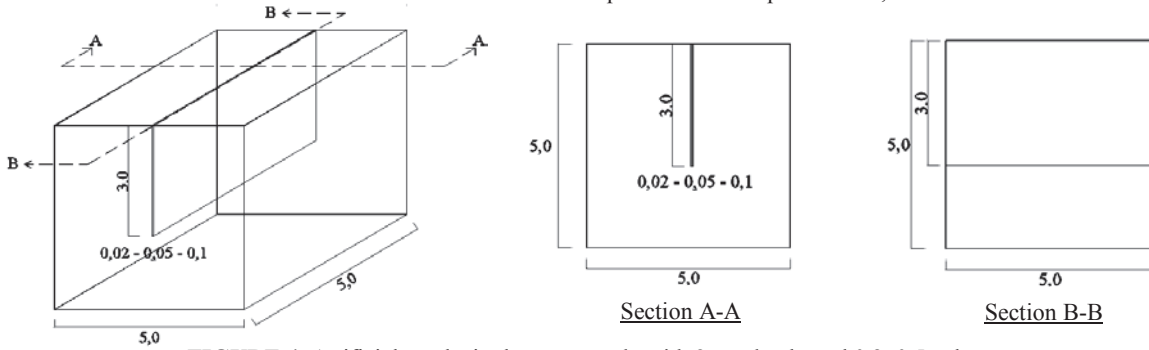

FIGURE 4. Artificial cracks in the test sample with 3 cm depth and 0.2, 0.5 and 1 mm width

The observation on mortar was done by enlarging the photograph, enlarging photo on one side to see how high calcium carbonate produced at the cracks of the mortar, then draw a straight line so as to assume the height of calcium carbonate produced of both sides is the same as it is considered that the height of calcium carbonate produced at the other side will grow with the same size as the time goes by.

RESULTS AND DISCUSSIONS

From the job mix design, the materials needed for the 12 pieces of mortar are according to Table 2 and Table 3.

TABLE 2. The composition of the mortar-forming agent with bacteria

Material	Weight			Water
	10 ⁴ Cells/ml of water	10 ⁵ Cells/ml of water	10 ⁶ Cells/ml of water	
Cement	1.060 gram	1.060 gram	1.060 gram	460 ml
Sand	2.915 gram	2.915 gram	2.915 gram	
Bacteria	4.600.000 Cells	46.000.000 Cells	460.000.000 Cells	

TABLE 3. The composition of the non-bacterial mortar-forming agent

Material	Weight
Cement	1.060 gram
Sand	2.915 gram
Water	460 ml

From the observation of the test samples with photo enlargement resulted that there were 4(four) test samples that had improvement. The mixing method is the method which shows the result of the repair while the injection method and curing method do not.

- 1) The composition of bacteria 10⁴ Cells/ml of water with 0.2 mm crack width and 2 cm crack depth

The improvement of cracks in the bacterial composition 10⁴ Cells/ml of water is the mortar cracks with 0.2 mm width and 2 cm depth as shown in Figure 5.

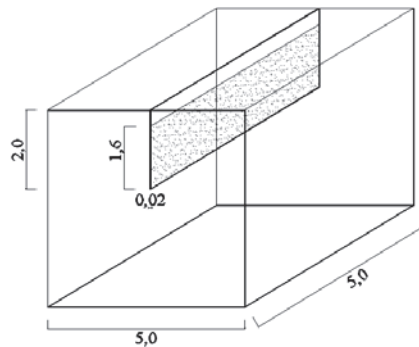

FIGURE 5. Mortar with cracks at 0.2 mm width and 2 cm length

Figure 5 shows that calcium carbonate produced 1.6 cm bacteria and filled 80% of crack. The detailed improvement of crack at 60 days is shown in Figure 6.

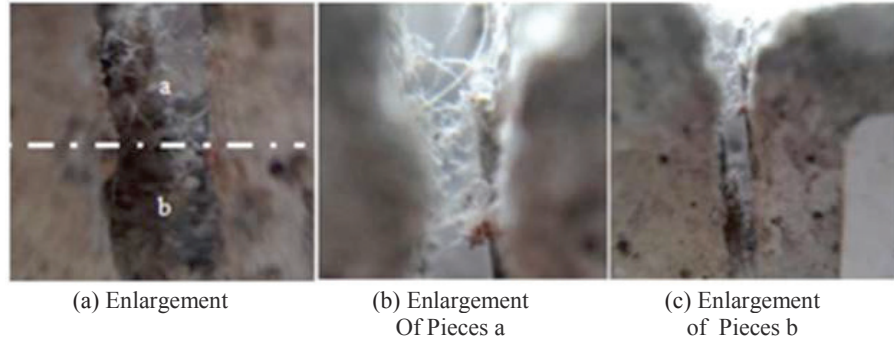

FIGURE 6. Detailed improvement of repair on mortar

Figure 6 shows a 60-day mortar, Figure 6 (a) is a photograph with magnification on the side position showing details of the growth of fine yarns that will eventually form a solid so as to fill the crack at a certain age. Figure. 6 (b) is a photograph; with an enlarged upper side view, shows a change even though it is not solid yet. Figure 6 (c) is a cut-up of image b in the lower position wherein the growth of fine yarns has been solid.

2) The composition of bacteria 10^5 Cells/ml of water with 0,5 mm crack width and 2 cm crack depth

Improved cracks in bacterial composition 10^5 Cells/ml of water is a mortar crack with 0.5 mm width and 2 cm depth can be seen in Figure 7.

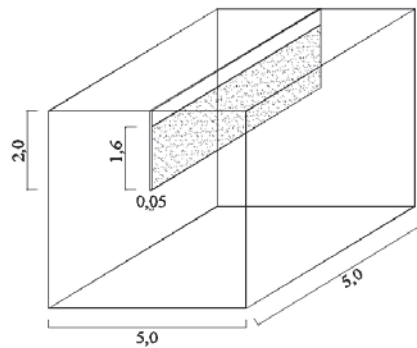

FIGURE 7. Mortar with cracks at 0.5 mm width and 2 cm length

Figure 7 shows mortar with a crack width of 0.5 mm and a crack length of 2 cm, a depth of calcium carbonate produced by bacteria is 1.6 cm. From the above calculation, the crack can be repaired by 80%.

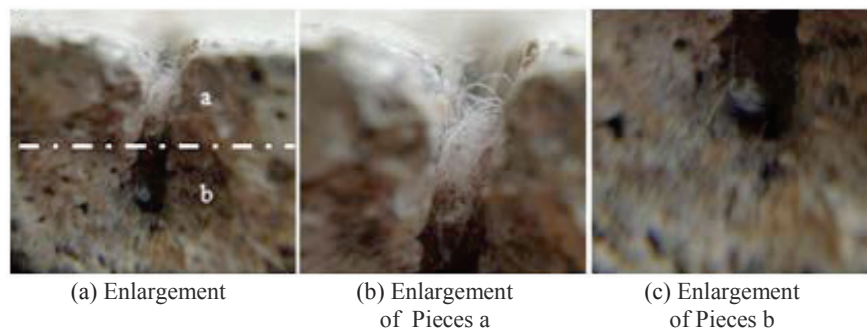

FIGURE 8. Detailed repair improvement on mortar

From Figure 8 (a) shows details of the changes to cracks in the mortar. Figure 8 (b) is a photograph with an enlarged upper side view, of which the image shows a change even though it is not yet solid. Figure 8 (c) is a cut-up image in

the lower position wherein the addition of fine threads has been solid.

3) Composition of bacteria 10^5 Cell/ml of water with 0,5 mm crack width and 3 cm crack depth

Repaired crack with the composition of bacteria 10^5 Cells/ml of water at mortar cracks with 0.5 mm width and 3 cm depth can be seen in Figure 9.

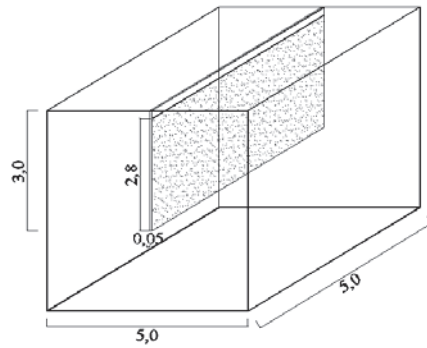

FIGURE 9. Mortar with cracks at 0.5 mm width and 3 cm length

In Figure 9 shows with a crack width of 0.5 mm and a length of 3 cm, the depth of calcium carbonate produced by bacteria is 2.8 cm, from the analysis of the improvement reaches up to 93.33%. Detailed improvements in Figure 10 showing the 60-day mortar age.

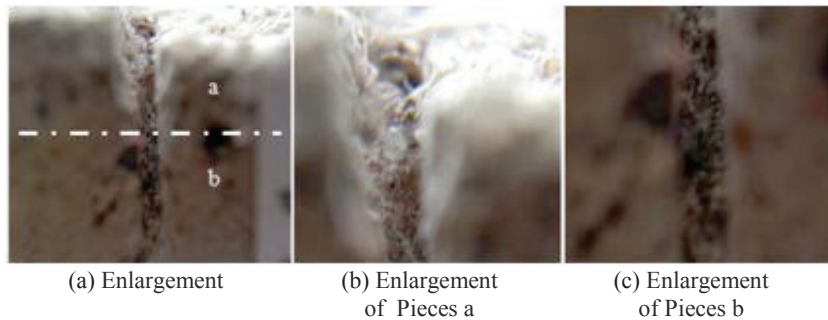

FIGURE 10. Detailed developmental improvement on mortar

Figure 10 (a) shows the detail of the increase of the finely dyed threads, Figure 10 (b) is the top of the side view, of an image showing the increase of solid threads which almost filled the crack in the test sample. Figure 10 (c) is a top cut image in which the filling of crack is almost complete.

4) The composition of bacteria 10^6 Cell/ml of water with 0,2 mm crack width and 1 cm crack depth

Repaired crack in bacterial composition 10^6 Cells/ml of water i.e mortar crack with width 0,2 mm and depth 1 cm. Repaired crack in bacterial composition 10^6 Cells/ml of water is a mortar crack with 0.2 mm width of and 1 cm a depth of can be seen in Figure 11.

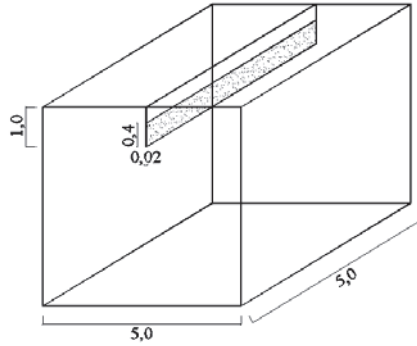

FIGURE 11. Mortar with a crack depth of 1 cm and a width of 0.2 mm

Figure 11 shows the crack width of 0.2 mm and 1 cm long, the calcium carbonate depth produced by bacteria of 0.4 cm, from the analysis of the improvement, it can reach 40%.

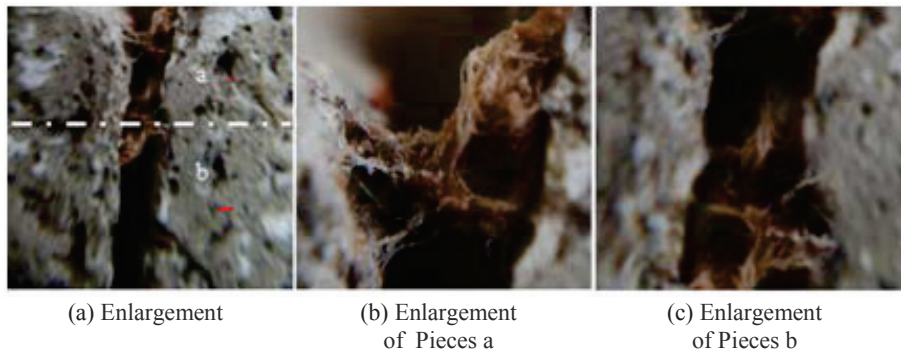

FIGURE 12. Detailed repair improvement on mortar

In Figure 12 (a) shows the details of the growth of fine yarn which was not solid yet, Figure 12 (b) shows the growth of the resulting yarns less than the other test sample. Figure 12 (c) is a cut-off image b wherein the addition of fine yarns is not yet perfect.

Of the 3 methods that have been analyzed, the improvement of the mortar cracks can be summarized as Table 4.

Cracking Dimensions	The content of Calcium Carbonate (%)		
	10 ⁴ Cells/ml of water	10 ⁵ Cells/ml of water	10 ⁶ Cells/ml of water
0,2 mm - 1 cm	0	0	40.00
0,2 mm - 2 cm	80.00	0	0
0,5 mm - 2 cm	0	80.00	0
0,5 mm - 3 cm	0	93.33	0

Table 4 shows that all bacterial compositions can produce improvements to mortar cracks, as can be seen in Figure 13.

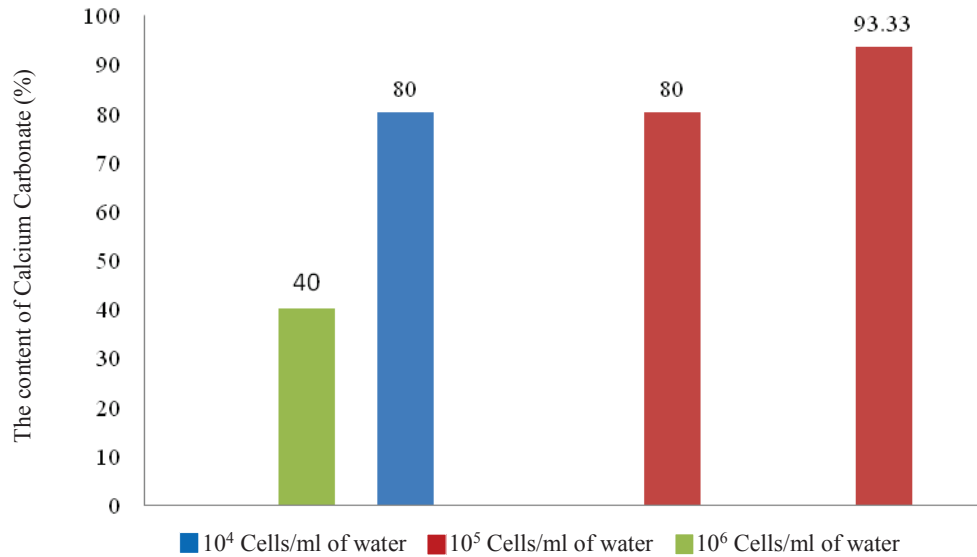

FIGURE 13. Graph of crack repair with 3 compositions

Figure 13 shows that of the 3 compositions that have been performed that the most effective composition produces calcium carbonate is a bacterial composition of 10^5 Cells/ml of water. At a crack width of 0.5 mm and a depth of 3 cm, mortar crack can be filled up to 93.3%.

ACKNOWLEDGMENTS

The authors would like to thank to the parties who have assisted with the completion of this research and the laboratory facilities at the Department of Civil Engineering of Faculty of Engineering of Sriwijaya University, Palembang, Indonesia.

CONCLUSIONS

Based on the analysis of the results of research mixing of concrete materials with bacteria that have been done, can be drawn conclusion as follows:

- From the 3 Methods, it can be concluded that mixing method is the most effective method to cover the crack in the concrete, while the other 2 method curing method and injection method cannot.
- Of the 3 compositions of the bacteria which were used; 10^4 Cells/ml of water, 10^5 Cells/ml of water and 10^6 Cells/ml of water, it be can be concluded that is for the composition of 10^5 Cells/ml of water is the largest composition of crack repair, improvement up to 93,33% on the crack dimension with 0.5 mm width and 3 cm depth.

REFERENCES

1. S.Soundharya and Dr.K.Nirmalkumar, Internasional Journal of Engineering Science Invention Research & Development, 162-4 (2014).
2. Sujatha S., Sarayu K., Annaselvi M., Ramachandra Murty A., Ramesh Kumar V., Nagesh R. Iyer, Journal of Civil Engineering Research 4(2A), 51-54 (2014).
3. Jagadeesha Kumar, B. G., Prabhakara, R., and Pushpa, H., Int J Eng Adv Technol, 2 (2013).
4. H.M. Jonkers, "Bacteria-based self-healing concrete" (*Delft University of Technology, 2011*).
5. Adriyati, M, "Bacillus Subtillic Bacteria Composition with hydrogel encapsulation for self-healing concrete application" (*University of Gajah Mada 2014*).
6. Reddy, S. V., Satya, A. K., Rao, S. M., and Azmatunnisa, M., International Journal of Advances in Engineering & Technology, 4(2), 392 (2012).