

Electrospun polyvinylpyrrolidone (PVP)/green tea extract composite nanofiber mats and their antioxidant activities

PAPER

Electrospun polyvinylpyrrolidone (PVP)/green tea extract composite nanofiber mats and their antioxidant activities

To cite this article: Pusporini Pusporini *et al* 2018 *Mater. Res. Express* **5** 054001

View the [article online](#) for updates and enhancements.



PAPER

Electrospun polyvinylpyrrolidone (PVP)/green tea extract composite nanofiber mats and their antioxidant activities

RECEIVED
31 January 2018REVISED
15 April 2018ACCEPTED FOR PUBLICATION
2 May 2018PUBLISHED
16 May 2018Pusporini Pusporini^{1,2}, Dhewa Edikresnha^{1,2}, Ida Sriyanti^{1,2}, Tri Suciati³,
Muhammad Miftahul Munir^{1,2,4}  and Khairurrijal Khairurrijal^{1,2,4} ¹ Department of Physics, Faculty of Mathematics and Natural Sciences, Institut Teknologi Bandung, Jalan Ganesa 10, Bandung 40132, Indonesia² Research Center for Biosciences and Biotechnology, Institute for Research and Community Services, Jalan Ganesa 10, Bandung 40132, Indonesia³ Department of Pharmaceutics, School of Pharmacy, Institut Teknologi Bandung, Jalan Ganesa 10, Bandung 40132, Indonesia⁴ Authors to whom any correspondence should be addressed.E-mail: miftah@fi.itb.ac.id and krjial@fi.itb.ac.id**Keywords:** polyvinylpyrrolidone, electrospinning, green tea, antioxidant activity, composite nanofiber, hydrogen bond, molecular interaction**Abstract**

Electrospinning was employed to make PVP (polyvinylpyrrolidone)/GTE (green tea extract) composite nanofiber mats. The electrospun PVP nanofiber mat as well as the PVP/GTE nanofiber mats were uniform. The average fiber diameter of PVP/GTE composite nanofiber mat decreased with increasing the GTE weight fraction (or decreasing the PVP weight fraction) in the PVP/GTE solution because the PVP/GTE solution concentration decreased. Then, the broad FTIR peak representing the stretching vibrations of O–H in hydroxyl groups of phenols and the stretching of N–H in amine groups of the GTE paste shifted to higher wavenumbers in the PVP/GTE composite nanofiber mats. These peak shifts implied that PVP and catechins of GTE in the PVP/GTE composite nanofiber mats had intermolecular interactions via hydrogen bonds between carbonyl groups of PVP and hydroxyl groups of catechins in GTE. Lastly, the antioxidant activity of the PVP/GTE composite nanofiber mat increased with reducing the average fiber diameter because the amount of catechins in the composite nanofiber mat increased with the increase of surface area due to the reduction of the average fiber diameter.

1. Introduction

Camellia sinensis L., or tea, is a beverage from *Theaceae* family that is widely consumed in the world [1–3]. Due to different processing techniques, tea can thus be divided into green tea, oolong tea, white tea, and black tea. Each type of tea has a unique character, taste, and chemical profile [4–6]. Green tea contains many compounds, such as caffeine, theanine, theaflavins, theobromine, theophylline, and phenolic acids, while the most abundant compound is flavanols, also known as catechins [1, 4, 7, 8]. The antioxidant activity of green tea is the highest, followed by oolong tea, and then black tea [7]. Aside from having high level of antioxidant, green tea has several benefits, such as reducing cholesterol solubility, giving protection against neurodegenerative diseases, and offering protection against various cancers [9].

To make a full use of green tea, it should have good bioavailability and absorption [1, 4, 7, 8]. However, catechins have a relatively high molecular weight (300–450 g mol⁻¹) and low bioavailability; therefore, only 0.2%–2% of the amount of catechins consumed can enter into the blood plasma [10]. To overcome the problems of low bioavailability and absorption of catechins, some efforts have been conducted including the modification of pH for the absorption [1], the use of surfactants [4], and the implantation into chitosan nanoparticles [11]. Another way is the particle size reduction of catechins by encapsulating them into polymer nanofibers [12–14]. Unfortunately, the study on green tea extract or catechins encapsulation into polymer

nanofibers and their antioxidant activities is very rare as indicated by only a very recent report on electrospun poly(2-hydroxyethyl methacrylate) microfibers loaded with catechins [15].

Polyvinyl pyrrolidone (PVP) along with polyvinyl alcohol (PVA) and polyvinyl acetate (PVAc) are vinyl polymers that are extensively used for the development of oral controlled-release products [16–23]. From the crystalline state point of view, the vinyl polymers are amorphous in nature. Then, based on the water solubility, PVP is a water soluble polymer. PVA is also soluble in water, but its water solubility depends on the degree of polymerization, hydrolysis, and solution temperature. On the other hand, PVAc is water insoluble with slight hydrophilic character so that it is able to absorb water to a slight extent. Among them, PVP is often used for solid dispersions containing amorphous drugs in which amorphous-state drugs show improved dissolution rates compared to their crystalline counterparts [12, 18].

To the best of our knowledge, the study on composite fibers of PVP/catechins or PVP/green tea extract (GTE) produced using electrospinning technique has not been reported. This paper describes the syntheses of PVP nanofiber mats loaded by green tea extract (GTE) using electrospinning technique. Ethanol GTE was prepared by using the maceration method. Morphologies of the electrospun PVP/GTE composite nanofiber mats were observed by a scanning electron microscope (SEM). Their fiber diameter distributions were determined by analyzing the obtained SEM images. A Fourier-transform infrared (FTIR) spectrometer was used to characterize functional groups of the obtained composite nanofibers. 2,2-diphenyl-1-picrylhydrazyl (DPPH) assay was then applied to evaluate their antioxidant activities.

2. Experimental

Polyvinylpyrrolidone (PVP) with molecular weight of $1300\,000\text{ g mol}^{-1}$ was purchased from Sigma-Aldrich and ethanol was obtained from a local chemical supplier. Dried green tea leaves obtained from a local store in the city of Bandung, Indonesia have been harvested from the tea plantation area in the regency of Garut, the province of West Java, Indonesia. As the name suggests, it looks greenish and a bit rough with its famous fragrance.

Concentrated green tea extract (GTE) was prepared by employing the ethanol maceration method. First, the dried green tea leaves were ground and then macerated using ethanol in a stoppered container and allowed to stand at room temperature for five days. The ethanol solvent was changed frequently until the extraction process was completed. The mixture was strained and the remaining solid was squeezed to remove all the remaining liquid. The extract solution was then concentrated using a rotary evaporator (Janke & Kunkel, IKA-Labortechnik) to obtain GTE paste.

A PVP solution was made by dissolving PVP in ethanol with concentration of 10 wt% and the mixture was then stirred using a magnetic stirrer at $40\text{ }^{\circ}\text{C}$ until a homogeneous solution was obtained. To obtain a GTE solution, the GTE paste was dissolved in ethanol at concentration of 10 wt% and stirred at room temperature for 2 h until a homogeneous solution was obtained. The PVP and GTE solutions were mixed so that the weight compositions of GTE solution in the final solution were 6, 8, and 10 wt%. The PVP/GTE solution was then stirred at room temperature until a homogeneous solution was obtained.

To get PVP/GTE composite nanofiber mats, each prepared PVP/GTE solution was inserted into a syringe with needle inner diameter of 0.45 mm and then electrospun by using electrospinning apparatus (Nachriebe 600) as schematically illustrated in figure 1. The electrospinning process employed the following parameters: the distance between the syringe needle tip and the collector of 10 cm, flow rate of 0.5 ml h^{-1} , and applied voltage of 12.5 kV. The environmental parameters including the relative humidity and temperature of the electrospinning chamber were kept at 55% and $25\text{ }^{\circ}\text{C}$, respectively.

Morphology and fibers diameter of the obtained PVP/GTE composite nanofiber mats were observed using a scanning electron microscope (SEM) (JEOL, JSM-6360LA) with the excitation voltage of 15 kV. Functional groups in the composite nanofiber mats were analyzed using a Fourier-Transformed Infrared (FTIR) Spectrometer (Bruker, Alpha) with the wavenumber in the range of $500\text{ to }4000\text{ cm}^{-1}$. The antioxidant activity was tested by using 2, 2-diphenyl-1-picrylhydrazyl (DPPH) assay to confirm the presence of GTE antioxidant compounds in the composite nanofiber mats.

To conduct the antioxidant activity test, a 50 ppm DPPH solution was made first by dissolving DPPH into ethanol. Afterward, the PVP/GTE composite nanofiber mat was dissolved as well into ethanol forming a 50 ppm nanofiber solution. The UV-vis absorbance of DPPH solution was monitored at wavelength of 514–517 nm [7, 24] using a UV-vis spectrophotometer (Beckman, DU-7500i). Subsequently, the DPPH solution and each nanofiber solution were mixed at ratio of 1:1, stirred, and then incubated inside a dark room. The absorbance of the mixture solution was again checked after 30 min. The antioxidant activity of the GTE inside the composite nanofiber mat reduced the absorbance at the monitored wavelength of DPPH.

The antioxidant activity (%AA) of the PVP/GTE composite nanofiber solution was determined by equation (1) [25].

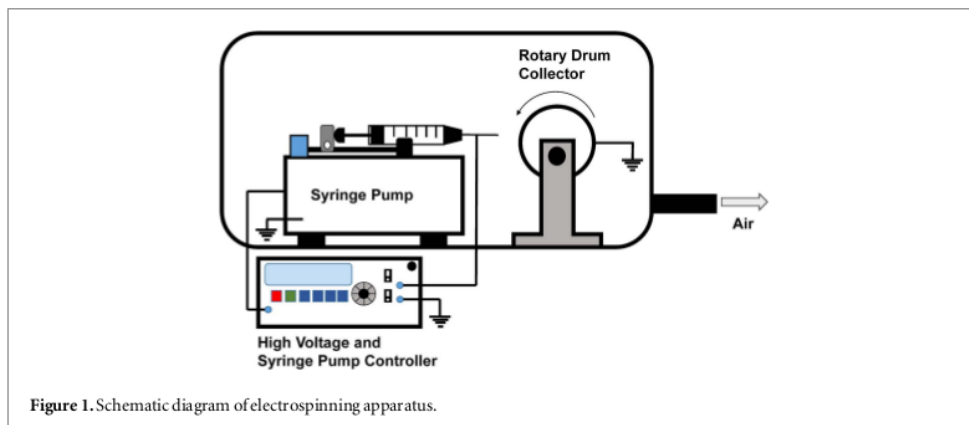

Figure 1. Schematic diagram of electrospinning apparatus.

$$\%AA = \frac{(A_{control} - A_{sample})}{A_{control}} \times 100 \quad (1)$$

where $A_{control}$ is the absorbance of the DPPH solution without the presence of GTE and A_{sample} is the absorbance of the nanofiber solution with the presence of GTE in the PVP/GTE composite nanofiber mat.

3. Results and discussion

3.1. SEM Images

Macroscopically, the existence of GTE in a PVP fiber mat can be confirmed by looking at its color. The electrospun PVP and PVP/GTE composite fiber mats were successfully formed but with declining flexibility over time. The color of PVP fiber mat was white, while that of PVP/GTE composite fiber mat was greenish brown. The SEM images and fiber diameters of electrospun PVP and PVP/GTE fiber mats are shown in figure 2. By analyzing the SEM images of the fiber mats, the fiber diameter distributions along with the average fiber diameters can be determined using Origin software with randomly selected fibers at different 100 points.

Figure 2(a) shows the SEM image of electrospun nanofiber mat obtained from the 10 wt% PVP solution. The PVP nanofiber mat had an average fiber diameter (D_{ave}) of 563 nm as seen in figure 2(e). Figures 2(b)–(d) present the SEM images of electrospun PVP/GTE composite nanofiber mats obtained from the solutions of PVP loaded by 6, 8, and 10 wt% GTE, respectively. Figures 2(f)–(h) display the fiber diameter distributions of the PVP/GTE (6, 8, and 10 wt%) composite nanofiber mats, respectively. Their average fiber diameters were 386, 379, and 344 nm, respectively. To evaluate the fiber diameter homogeneity of nanofiber mat, coefficient of variation (CV) is usually used in which $CV = SD/D_{ave}$, where SD is the standard deviation of fiber diameter and D_{ave} is the average fiber diameter [26]. If CV is less than 0.3, the nanofiber mat is uniform. Otherwise, it is not uniform. The obtained PVP nanofiber mat shown in figure 2(a) was therefore uniform. With the presence of GTE, the PVP/GTE composite nanofiber mats were kept uniform, as given in figures 2(f)–(h).

It can be seen in figure 2 that the average fiber diameter of PVP/GTE composite nanofiber mat decreased when the weight fraction of GTE in the PVP/GTE solution increased. In other words, the decrease of PVP weight fraction contained in the PVP/GTE solution reduced the average fiber diameter of PVP/GTE composite nanofiber mat. Note that the main component of the solution that forms electrospun nanofibers is polymer itself, as it is already known. Thus, if the polymer concentration increases, the average fiber diameter also increases [27]. As the viscosity of PVP increases with its concentration [28] and the degree of polymer chain entanglement increases with its viscosity [29], the increase of average diameter of electrospun PVP/GTE composite nanofiber mat with the increase of GTE weight fraction in the PVP/GTE solution can thus be explained.

Moreover, it is well known that there is a minimum polymer concentration to obtain uniform nanofibers [30]. In other words, if the polymer concentration is smaller than its minimum concentration, the electrospun nanofibers then have beads (non-uniform or beaded nanofibers). It is worth mentioning that polymer molecular weight, which indicates the number of entanglements of polymer chains in a solution and therefore solution viscosity, plays an essential role to establish the minimum polymer concentration. As the PVP nanofiber mat obtained was uniform without beads, the PVP concentration employed was certainly higher than the minimum PVP concentration required. Noting that PVP and green tea catechins have molecular weights of 1300 000 and 500 g mol⁻¹ [31], respectively, the addition of GTE solution to the PVP solution does not make the PVP/GTE

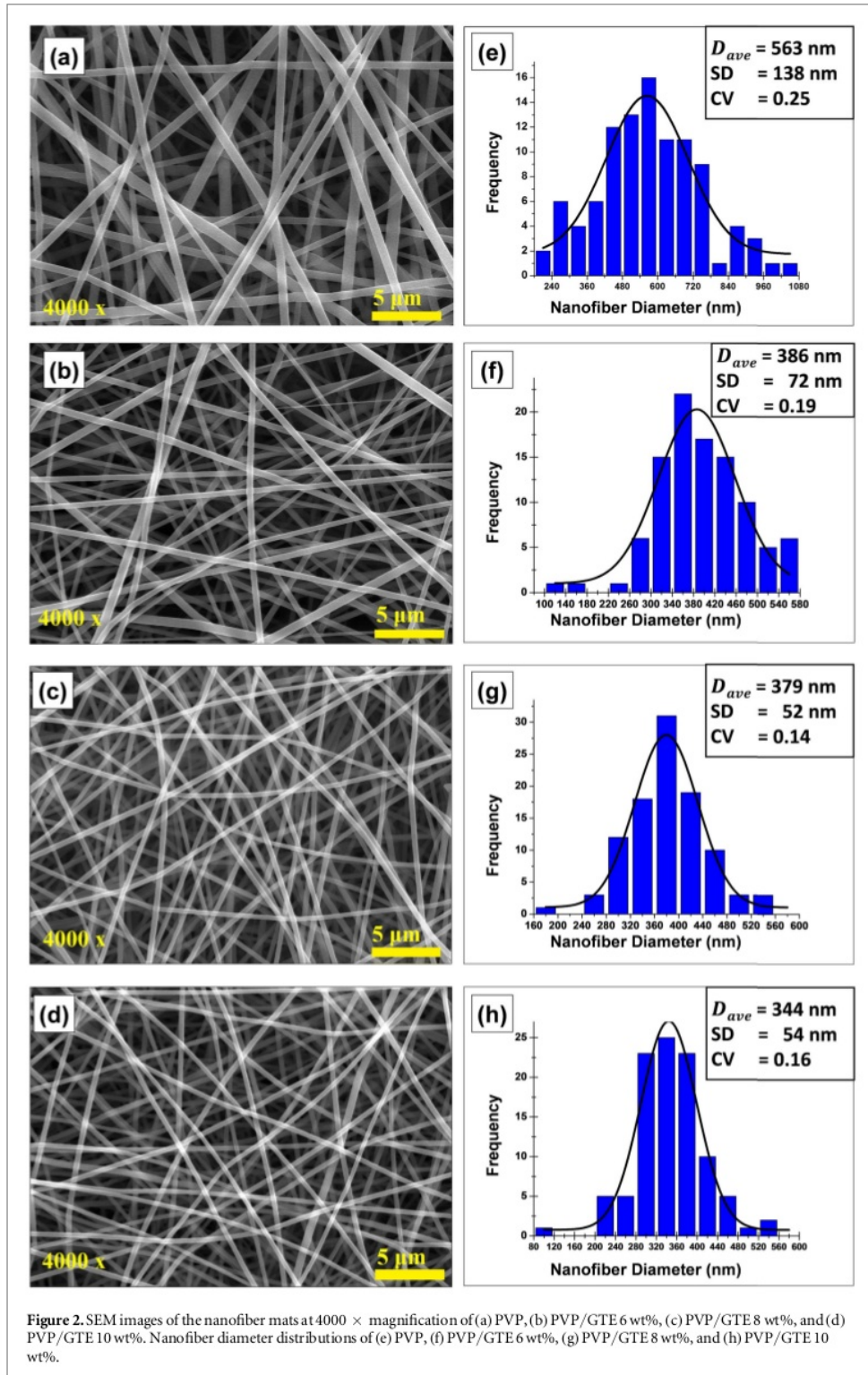

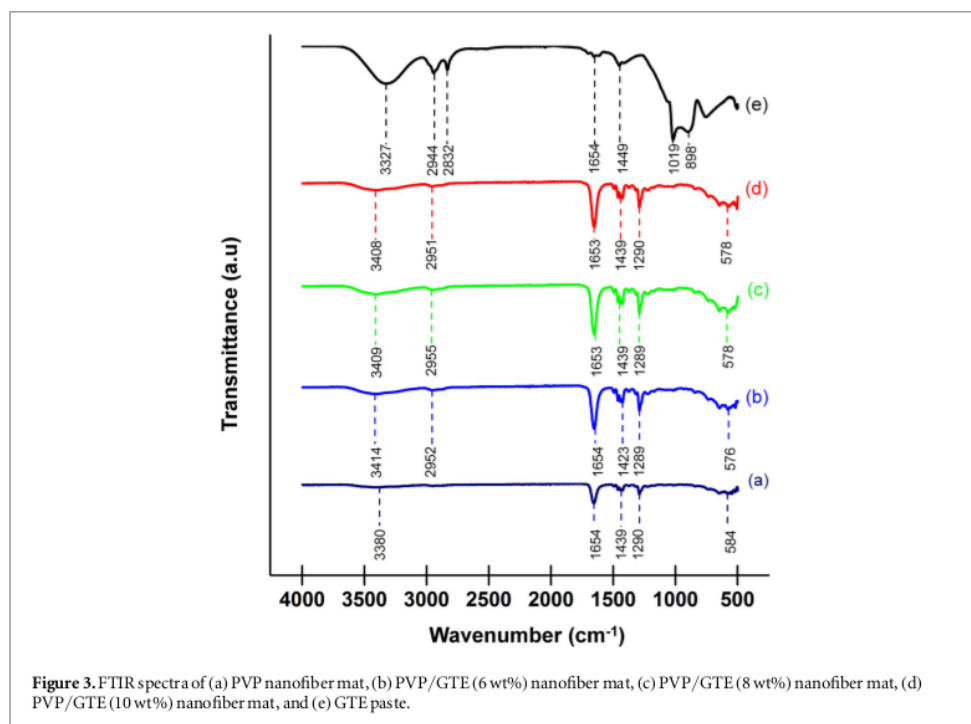

solution concentration change significantly and the PVP/GTE nanofiber mats were therefore uniform with no beads.

3.2. FTIR spectra

FTIR analysis was conducted to observe functional groups of the PVP nanofiber mat affected by the presence of GTE in the electrospun PVP/GTE composite nanofiber mats. The FTIR spectra of GTE paste, PVP nanofiber mat, and PVP/GTE composite nanofiber mats are presented in figure 3. In the FTIR spectrum of PVP nanofiber mat, there was a broad peak at 3380 cm^{-1} in the range of $3000\text{--}3700\text{ cm}^{-1}$, which refers to the O–H stretching vibration of water molecules [21, 30–33]. It means that the PVP nanofiber mat most likely captured water vapor of the moist air because PVP is hydrophilic [21] and possible to make hydrogen bonds between C=O groups of pyrrolidone rings in the presence of moist air [19]. Subsequently, the peak at 1654 cm^{-1} is attributed to the stretching vibrations of C=O and N–C [21, 34], while that at 1439 cm^{-1} is assigned to the CH deformation of CH_2 cyclic groups [21]. Then, the C–N stretching of amide III band and the wagging of CH_2 are represented by the peak at 1290 cm^{-1} [21, 34]. Lastly, the in-plane bending of N–C=O is associated to the peak at 584 cm^{-1} [34]. A minor peak appeared at around 2950 cm^{-1} due to the asymmetric stretching of CH_2 of pyrrole ring [29].

Some peaks in the FTIR spectrum of GTE paste in figure 3 are given as follows [35, 36]. The broad peak at 3327 cm^{-1} represents the stretching vibrations of O–H in hydroxyl groups of phenols and the stretching of N–H in amine groups. Next, the peaks at 2944 and 2832 cm^{-1} refers the stretching of C–H in alkane and that of O–H in carboxyl groups, respectively. Both the stretching of C=O in polyphenols and that of C=C in aromatic rings is connected to the strong peak at 1654 cm^{-1} . Then, the stretching of C–O in amino acids is correlated to the strong peak at 1019 cm^{-1} . Finally, the weak peak at 898 cm^{-1} is assigned to the out of plane bending of C–H bonds. Based on the observed FTIR spectrum peaks, the GTE paste was therefore rich in polyphenols, carboxyl acids, and amino acids, as previously reported [1].

Figure 3 also shows the FTIR spectra of the PVP/GTE composite nanofiber mats due to the addition of GTE into the PVP nanofiber mats. The broad peaks at 3414 , 3409 , and 3408 cm^{-1} correspond to the O–H stretching vibrations of phenols and the stretching of N–H in amines of the PVP/GTE composite nanofiber mats with 6, 8, and 10 wt% GTE, respectively. Noting that the O–H stretching vibration of the PVP nanofiber mat and the O–H stretching vibrations and the stretching of N–H of the GTE paste had the peaks at 3380 and 3327 cm^{-1} , respectively, the presence of GTE in the PVP/GTE composite nanofiber mats resulted in the peak shifts towards the larger wavenumbers. These peak shifts indicates that the bond strengths of O–H and N–H in the PVP/GTE composite nanofiber mats increased. Moreover, these peak shifts suggests that the PVP/GTE composite

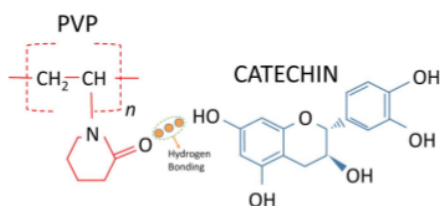

Figure 4. Schematic diagram of hydrogen bond between PVP and catechin in GTE of the PVP/GTE composite nanofiber mats.

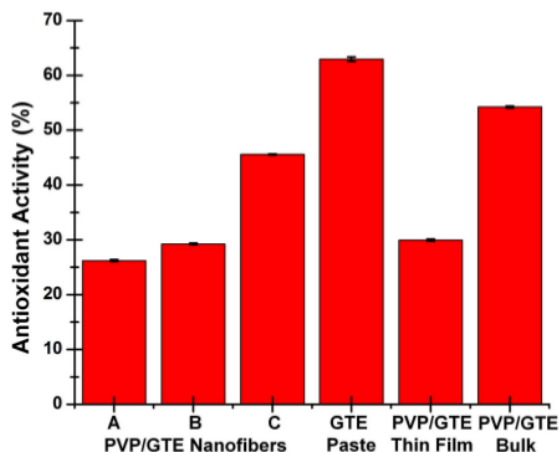

Figure 5. The antioxidant activities of PVP/GTE composite nanofiber mats for (A) PVP/GTE (6 wt% GTE) composite Nanofiber mat, (B) PVP/GTE (8 wt% GTE) composite Nanofiber mat (C) PVP/GTE (10 wt% GTE) composite Nanofiber mat, GTE paste, PVP/GTE thin film, and PVP/GTE bulk.

nanofiber mats had intermolecular interactions between PVP and catechins in GTE via hydrogen bonds developed between carbonyl groups of PVP and hydroxyl groups of catechins in GTE [19] as illustrated by the schematic diagram in figure 4. The hydrogen bonds might be strong as indicated by the peak around $1653\text{--}1654\text{ cm}^{-1}$ (lower than 1664 cm^{-1}) due to the stretching vibration of C=O of all PVP/GTE composite nanofiber mats [34].

Furthermore, broad peaks around $2951\text{--}2955\text{ cm}^{-1}$ are caused by the stretching of CH in alkanes of the PVP/GTE composite nanofiber mats. The CH deformation of CH_2 cyclic groups are related to the peaks around 1439 cm^{-1} [21]. The peak around 1290 cm^{-1} represents the C–N stretching of amide III band and the wagging of CH_2 [21, 34]. The peaks of $576\text{--}578\text{ cm}^{-1}$ are associated to the presence of in-plane bending of N–C=O [21].

3.3. Antioxidant activities

Polyphenols in tea, as already proven to exist in the GTE from the FTIR spectrum analysis, are famous for their antioxidant properties. The activity is primarily thought to be caused by the combination of hydroxyl groups and aromatic rings that build up their chemical structure which then able to bind and neutralize the lipid of free radicals. Catechin, which is a subclass of polyphenols, is responsible for the antioxidant activity in green tea. It was confirmed that green tea catechins have excellent electron donors and thus can scavenge radicals effectively [7]. In the present study, DPPH used as the free radical is stabilized by accepting electrons from the GTE antioxidant or hydrogen radicals which then turn into a stable molecule. The initial color of DPPH solution was purple and it will turn to mustard (near yellow) in the presence of antioxidant resulting in a reduction in absorbance value. From the previous study, green tea catechins and their epimers had radical scavenging ability up to 50% in the range of concentration of 1 to $3\text{ }\mu\text{M}$ [36].

Figure 5 shows the antioxidant activities of the GTE paste, PVP/GTE composite nanofiber mats loaded by 6, 8, and 10 wt% GTE, PVP/GTE thin film, and PVP/GTE bulk. The GTE paste had the highest antioxidant activity, which was $62.95 \pm 0.4\%$. The antioxidant activities of the PVP/GTE (6, 8, and 10 wt%) composite nanofiber mats were $26.21 \pm 0.09\%$, $29.25 \pm 0.17\%$, and $42.57 \pm 0.17\%$, respectively. These results

confirmed that the GTE was successfully incorporated into the PVP nanofibers. Moreover, these results also showed that the antioxidant activity of PVP/GTE composite nanofiber mat increased with the concentration of GTE loaded, which is in agreement with the previous reports on the chitosan/GTE film and gelatin/GTE film [37, 38].

The antioxidant activities of PVP/GTE thin film and PVP/GTE bulk were made as a comparison. The PVP/GTE thin film was made by smearing the PVP/GTE (10 wt%) solution on a microscope slide. The thin film solution was allowed to evaporate overnight at room temperature. Additionally, the PVP/GTE bulk was obtained by evaporating the PVP/GTE (10 wt%) bulk solution at temperature of 60 °C. As depicted in figure 5, the antioxidant activity of the PVP/GTE thin film was smaller than that of the PVP/GTE bulk. This is because the surface area of the thin film solution was larger than that of the bulk solution so that the amount of catechins evaporated from the thin film solution was higher than that from the bulk solution. The remaining catechins in the PVP/GTE thin film was therefore smaller than that of the PVP/GTE bulk. Furthermore, the antioxidant activity of the PVP/GTE thin film was smaller than that of the PVP/GTE (10 wt%) composite nanofiber mat. Although a much number of jets, in which each jet had hundreds nanometers in diameter, that made the composite nanofibers had a surface area much larger than that of the thin film solution, the amount of catechins remaining in the composite nanofiber is higher than that of the thin film. The reason for this could be that the electrospinning process promoted bonds between PVP and catechins in GTE so that catechins were bound relatively strongly to PVP as supported by the FTIR analyses of the PVP/GTE composite nanofiber mats.

The average fiber diameter of PVP/GTE composite nanofiber mat also seems to affect its antioxidant activity as well. It was found that the antioxidant activity of the PVP/GTE composite nanofiber mat increases with the reduction of its average fiber diameter. The smallest average fiber diameter of the PVP/GTE (10 wt%) gave the highest antioxidant activity. This finding is consistent with that previously reported on the antioxidant activity of *Garcinia mangostana* extract (GME) of the PVP/GME composite nanofiber mat [19]. This is because the smaller the average fiber diameter of the PVP/GTE composite nanofiber mat, the larger the surface area of the composite nanofiber mat becomes. As a result, the amount of catechins contained in the composite nanofiber mat increased.

4. Conclusion

Green tea extract (GTE) has successfully been loaded into PVP to form PVP/GTE composite nanofiber mats using electrospinning technique. The PVP nanofiber mat was uniform with an average fiber diameter of 563 nm. As the molecular weight of PVP is much higher than that of green tea catechins, the PVP/GTE nanofiber mats were also uniform. The average fiber diameters of PVP/GTE composite nanofiber mats loaded by 6, 8, and 10 wt% GTE were 386, 379, and 344 nm, respectively. The average fiber diameter of PVP/GTE composite nanofiber mat decreased with increasing the GTE weight fraction, thus decreasing the PVP weight fraction, in the PVP/GTE solution. The broad FTIR peak at 3327 cm^{-1} , which represented the stretching vibrations of O–H in hydroxyl groups of phenols and the stretching of N–H in amine groups in the GTE paste, shifted to 3414, 3409, and 3408 cm^{-1} for the PVP/GTE composite nanofiber mats with 6, 8, and 10 wt% GTE, respectively. These peak shifts suggested that the PVP/GTE composite nanofiber mats had intermolecular interactions between PVP and catechins in GTE via hydrogen bonds developed between carbonyl groups of PVP and hydroxyl groups of catechins in GTE. The GTE paste had the antioxidant activity of $(62.95 \pm 0.4)\%$, while those of the PVP/GTE composite nanofiber mats loaded by 6, 8, and 10 wt% GTE were (26.21 ± 0.09) , (29.25 ± 0.17) , and $(42.57 \pm 0.17)\%$, respectively. It is seen that the antioxidant activity of the PVP/GTE composite nanofiber mat increased with the reduction of its average fiber diameter. This is because the smaller the average fiber diameter of the PVP/GTE composite nanofiber mat, the larger the surface area of the composite nanofiber mat became and thus the higher the amount of catechins contained in the composite nanofiber mat was.

Acknowledgments

This research was financially supported by Directorate of Research and Community Engagement, Ministry of Research, Technology, and Higher Education, the Republic of Indonesia under the University's Excellence Research (PUPT) Grant in the fiscal years of 2016–2017.

ORCID iDs

Muhammad Miftahul Munir  <https://orcid.org/0000-0003-0894-9109>

Khairurrijal Khairurrijal  <https://orcid.org/0000-0002-9452-4192>

References

- [1] Chow H H and Hakim I A 2011 Pharmacokinetic and chemoprevention studies on tea in humans *Pharmacol. Res.* **64** 105–12
- [2] Sang S, Lambert J D, Ho C T and Yang C S 2011 The chemistry and biotransformation of tea constituents *Pharmacol. Res.* **64** 87–99
- [3] Yang C S and Hong J 2013 Prevention of chronic diseases by tea: possible mechanisms and human relevance *Annu. Rev. Nutr.* **33** 161–81
- [4] Naumovski N, Blades B L and Roach P D 2015 Food inhibits the oral bioavailability of the major green tea antioxidant epigallocatechin gallate in humans *Antioxidants* **4** 373–93
- [5] Alcazar A, Ballesteros O, Jurado J M, Pablos F, Martin M J, Vilches J L and Navalon A 2007 Differentiation of green, white, black, Oolong, and Pu-erh teas according to their free amino acids content *J. Agr. Food Chem.* **55** 5960–5
- [6] Rusak G, Komes D, Likić S, Horžić D and Kovač M 2008 Phenolic content and antioxidative capacity of green and white tea extracts depending on extraction conditions and the solvent used *Food Chem.* **110** 852–8
- [7] Senanayake S N 2013 Green tea extract: chemistry, antioxidant properties and food applications—a review *J. Funct. Foods* **5** 1529–41
- [8] Kerio L C, Wachira F N, Wanyoko J K and Rotich M K 2013 Total polyphenols, catechin profiles and antioxidant activity of tea products from purple leaf coloured tea cultivars *Food Chem.* **136** 1405–13
- [9] Zaveri N T 2006 Green tea and its polyphenolic catechins: medicinal uses in cancer and noncancer applications *Life Sci.* **78** 2073–80
- [10] Wiseman S, Mulder T and Rietveld A 2001 Tea flavonoids: bioavailability *in vivo* and effects on cell signaling pathways *in vitro* *Antioxid. Redox Sign.* **3** 1009–21
- [11] Dube A, Nicolazzo J A and Larson I 2010 Chitosan nanoparticles enhance the intestinal absorption of the green tea catechins (+)-catechin and (–)-epigallocatechin gallate *Eur. J. Pharm. Sci.* **41** 219–25
- [12] Ignatious F, Sun L, Lee C P and Baldoni J 2010 Electrospun nanofibers in oral drug delivery *Pharm. Res.* **27** 576–88
- [13] Kenawy E R, Abdel-Hay F I, El-Newehy M H and Wnek G E 2009 Processing of polymer nanofibers through electrospinning as drug delivery systems *Mater. Chem. Phys.* **113** 296–302
- [14] Seif S, Franzen L and Windbergs M 2015 Overcoming drug crystallization in electrospun fibers—Elucidating key parameters and developing strategies for drug delivery *Int. J. Pharm.* **478** 390–7
- [15] Ghitescu R E, Popa A M, Popa V I, Rossi R M and Fortunato G 2015 Encapsulation of polyphenols into pHEMA e-spun fibers and determination of their antioxidant activities *Int. J. Pharm.* **494** 278–87
- [16] Novoa G A, Heinämäki J, Mirza S, Antikainen O, Colarte A I, Paz A S and Yliruusi J 2005 Physical solid-state properties and dissolution of sustained-release matrices of polyvinylacetate *Eur. J. Pharm. Biopharm.* **59** 343–50
- [17] Kadajji V G and Betageri G V 2011 Water soluble polymers for pharmaceutical applications *Polymers* **3** 1972–2009
- [18] Broman E, Khoo C and Taylor L S 2001 A comparison of alternative polymer excipients and processing methods for making solid dispersions of a poorly water soluble drug *Int. J. Pharm.* **222** 139–51
- [19] Sriyanti I, Edikresna D, Rahma A, Munir M M, Rachmawati H and Khairurrijal K 2017 Correlation between structures and antioxidant activities of polyvinylpyrrolidone / *Garcinia mangostana* L. extract composite nanofiber mats prepared using electrospinning *J. Nanomater.* **2017** 9687896
- [20] Li X Y, Wang X, Yu D G, Ye S, Kuang Q K, Yi Q W and Yao X Z 2012 Electrospun borneol-PVP nanocomposites *J. Nanomater.* **2012** 731382
- [21] Rahma A, Munir M M, Khairurrijal K, Prasetyo A, Suendo V and Rachmawati H 2016 Intermolecular interactions and the release pattern of electrospun curcumin-polyvinyl (pyrrolidone) fiber *Biol. Pharm. Bull.* **39** 163–73
- [22] Park J Y, Lee I H and Bea G N 2008 Optimization of the electrospinning conditions for preparation of nanofibers from polyvinylacetate (PVAc) in ethanol solvent *J. Ind. Eng. Chem.* **14** 707–13
- [23] Nuryantini A Y, Edikresna D, Munir M M and Khairurrijal K 2015 Electrospun Polyvinylpyrrolidone as a carrier for leaves extracts of *Anredera cordifolia* (Ten.) Steenis *Mater. Sci. Forum* vol 827 (Zurich: Trans Tech Publications) pp 91–4
- [24] Ramos-Escudero D F, Condezo-Hoyos L A, Ramos-Escudero M and Yanez J A 2009 Design and assessment of the *in vitro* anti-oxidant capacity of a beverage composed of green tea (*Camellia sinensis* L.) and lemongrass (*Cymbopogon citratus* Stap) *Handbook of Green Tea and Health Research* (New York: Nova Science Publishers) pp 81–101
- [25] Suwantong O, Pankongadisak P, Deachathai S and Supaphol P 2014 Electrospun poly (L-lactic acid) fiber mats containing crude *Garcinia mangostana* extracts for use as wound dressings *Polym. Bull.* **71** 925–49
- [26] Matulevicius J, Kliucininkas L, Prasauskas T, Buivydiene D and Martuzevicius D 2016 The comparative study of aerosol filtration by electrospun polyamide, polyvinyl acetate, polyacrylonitrile and cellulose acetate nanofiber media *J. Aerosol Sci.* **92** 27–37
- [27] Ramakrishna S, Fujihara K, Teo W E, Lim T C and Ma Z 2005 *An Introduction to Electrospinning and Nanofibers* (Singapore: World Scientific) <https://www.worldscientific.com/worldscibooks/10.1142/5894>
- [28] Swei J and Talbot J B 2003 Viscosity correlation for aqueous polyvinylpyrrolidone (PVP) solutions *J. Appl. Polym. Sci.* **90** 1153–5
- [29] Shenoy S L, Bates W D, Frisch H L and Wnek G E 2005 Role of chain entanglements on fiber formation during electrospinning of polymer solutions: good solvent, non-specific polymer–polymer interaction limit *Polymer* **46** 3372–84
- [30] Andraday A L 2008 *Science and Technology of Polymer Nanofibers* (New Jersey: Wiley) ch 4 (<https://doi.org/10.1002/9780470229842.ch4>)
- [31] Naftalin R J, Afzal I, Cunningham P, Halai M, Ross C, Salleh N and Milligan S R 2003 Interactions of androgens, green tea catechins and the antiandrogen flutamide with the external glucose-binding site of the human erythrocyte glucose transporter GLUT1 *Brit. J. Pharmacol.* **140** 487–99
- [32] Munir M M, Iskandar F, Khairurrijal K and Okuyama K 2009 High performance electrospinning system for fabricating highly uniform polymer nanofibers *Rev. Sci. Instrum.* **80** 026106
- [33] Saroj A L, Singh R K and Chandra S 2013 Studies on polymer electrolyte poly (vinyl) pyrrolidone (PVP) complexed with ionic liquid: effect of complexation on thermal stability, conductivity and relaxation behaviour *Mat. Sci. Eng. B* **178** 231–8
- [34] Zhao C, Cheng H, Jiang P, Yao Y and Han J 2014 Preparation of lutein-loaded particles for improving solubility and stability by polyvinylpyrrolidone (PVP) as an emulsion-stabilizer *Food Chem.* **156** 123–8
- [35] Senthilkumar S R and Sivakumar T 2014 Green tea (*Camellia sinensis*) mediated synthesis of zinc oxide (ZnO) nanoparticles and studies on their antimicrobial activities *Int. J. Pharm. Pharm. Sci.* **6** 461–5 <https://innovareacademics.in/journal/ijpps/Vol6Issue6/9715.pdf>
- [36] Nanjo F, Goto K, Seto R, Suzuki M, Sakai M and Hara Y 1996 Scavenging effects of tea catechins and their derivatives on 1, 1-diphenyl-2-picrylhydrazyl radical *Free Radical Bio. Med.* **21** 895–902

- [37] Siripatrawan U and Harte BR 2010 Physical properties and antioxidant activity of an active film from chitosan incorporated with green tea extract *Food Hydrocolloid*. [24](#) 770–5
- [38] Wu J, Chen S, Ge S, Miao J, Li J and Zhang Q 2013 Preparation, properties and antioxidant activity of an active film from silver carp (*Hypophthalmichthys molitrix*) skin gelatin incorporated with green tea extract *Food Hydrocolloid*. [32](#) 42–51

Electrospun polyvinylpyrrolidone (PVP)/green tea extract composite nanofiber mats and their antioxidant activities

ORIGINALITY REPORT

18%

SIMILARITY INDEX

MATCHED SOURCE

1 **Ida Sriyanti, Dhewa Edikresnha, Annisa Rahma, Muhammad Miftahul Munir, Heni Rachmawati, Khairurrijal Khairurrijal. " Correlation between Structures and Antioxidant Activities of Polyvinylpyrrolidone/ L. Extract Composite Nanofiber Mats Prepared Using Electrospinning ", Journal of Nanomaterials, 2017** **247 words — 6%**
Crossref

★**Ida Sriyanti, Dhewa Edikresnha, Annisa Rahma, Muhammad Miftahul Munir, Heni Rachmawati, Khairurrijal Khairurrijal. " Correlation between Structures and Antioxidant Activities of Polyvinylpyrrolidone/ L. Extract Composite Nanofiber Mats Prepared Using Electrospinning ", Journal of Nanomaterials, 2017** **6%**
Crossref

EXCLUDE QUOTES ON

EXCLUDE MATCHES < 1%

EXCLUDE BIBLIOGRAPHY ON