

# Virtual augmented book chapter

*By* Bhakti Suprpto

# The Nine Pillars of Technologies for Industry 4.0

Edited by  
Wai Yie Leong, Joon Huang Chuah and Boon Tuan Tee

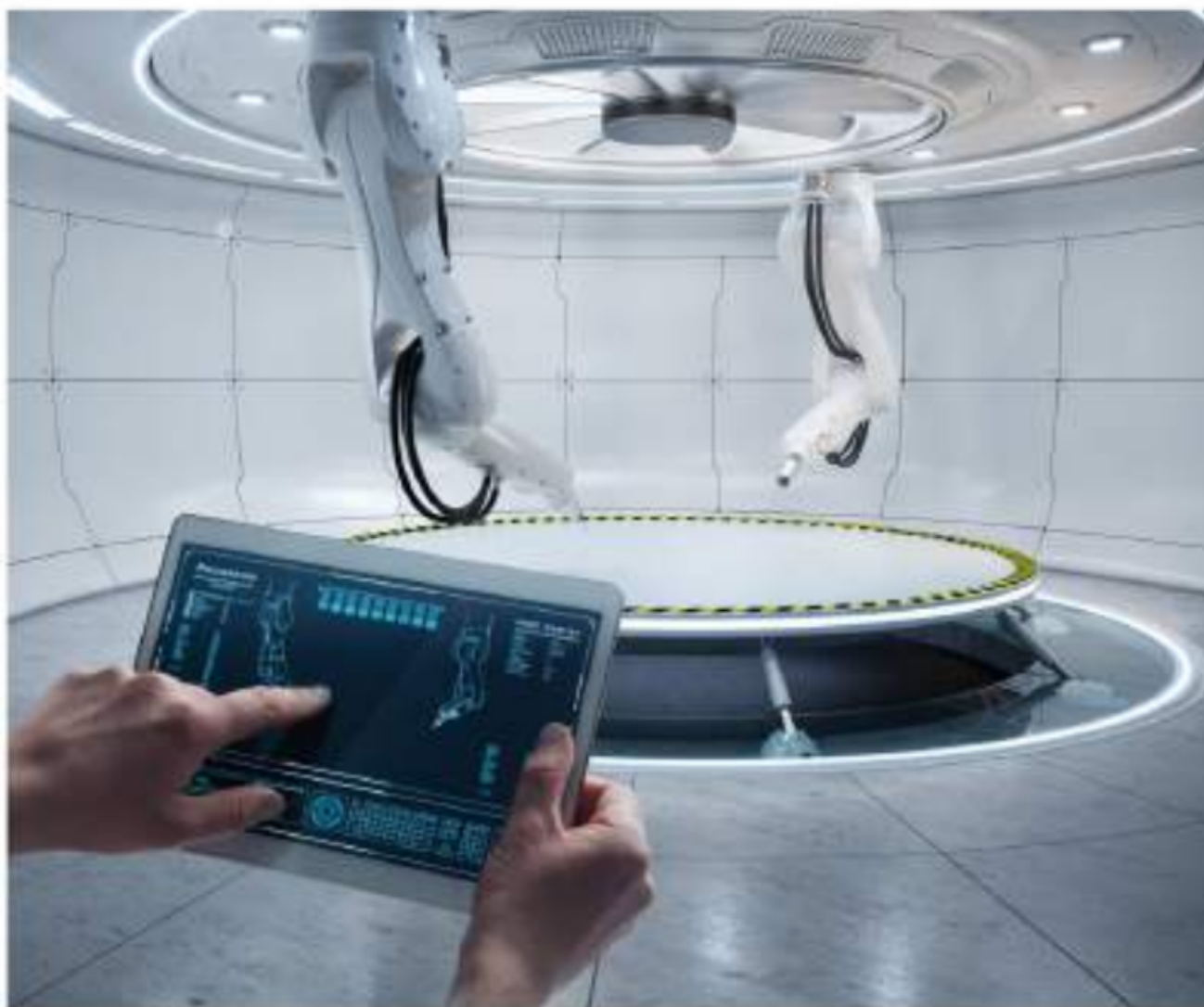

# The Nine Pillars of Technologies for Industry 4.0

## Other volumes in this series:

- Volume 9 **Phase Noise in Signal Sources** W.P. Robins
- Volume 12 **Spread Spectrum in Communications** R. Skaug and J.F. Hjelmstad
- Volume 13 **Advanced Signal Processing** D.J. Creasey (Editor)
- Volume 19 **Telecommunications Traffic, Tariffs and Costs** R.E. Farr
- Volume 20 **An Introduction to Satellite Communications** D.I. Dalgleish
- Volume 26 **Common-Channel Signalling** R.J. Manterfield
- Volume 28 **Very Small Aperture Terminals (VSATs)** J.L. Everett (Editor)
- Volume 29 **ATM: The broadband telecommunications solution** L.G. Cuthbert and J.C. Sapanel
- Volume 31 **Data Communications and Networks, 3rd Edition** R.L. Brewster (Editor)
- Volume 32 **Analogue Optical Fibre Communications** B. Wilson, Z. Ghassemlooy and I.Z. Darwazeh (Editors)
- Volume 33 **Modern Personal Radio Systems** R.C.V. Macario (Editor)
- Volume 34 **Digital Broadcasting** P. Dambacher
- Volume 35 **Principles of Performance Engineering for Telecommunication and Information Systems** M. Ghanbari, C.J. Hughes, M.C. Sinclair and J.P. Eade
- Volume 36 **Telecommunication Networks, 2nd Edition** J.E. Flood (Editor)
- Volume 37 **Optical Communication Receiver Design** S.B. Alexander
- Volume 38 **Satellite Communication Systems, 3rd Edition** B.G. Evans (Editor)
- Volume 40 **Spread Spectrum in Mobile Communication** O. Berg, T. Berg, J.F. Hjelmstad, S. Haavik and R. Skaug
- Volume 41 **World Telecommunications Economics** J.J. Wheatley
- Volume 43 **Telecommunications Signalling** R.J. Manterfield
- Volume 44 **Digital Signal Filtering, Analysis and Restoration** J. Jan
- Volume 45 **Radio Spectrum Management, 2nd Edition** D.J. Withers
- Volume 46 **Intelligent Networks: Principles and applications** J.R. Anderson
- Volume 47 **Local Access Network Technologies** P. France
- Volume 48 **Telecommunications Quality of Service Management** A.P. Oodan (Editor)
- Volume 49 **Standard Codecs: Image compression to advanced video coding** M. Ghanbari
- Volume 50 **Telecommunications Regulation** J. Buckley
- Volume 51 **Security for Mobility** C. Mitchell (Editor)
- Volume 52 **Understanding Telecommunications Networks** A. Valdar
- Volume 53 **Video Compression Systems: From first principles to concatenated codecs** A. Bock
- Volume 54 **Standard Codecs: Image compression to advanced video coding, 3rd Edition** M. Ghanbari
- Volume 59 **Dynamic Ad Hoc Networks** H. Rashvand and H. Chao (Editors)
- Volume 60 **Understanding Telecommunications Business** A. Valdar and I. Morfett
- Volume 65 **Advances in Body-Centric Wireless Communication: Applications and state-of-the-art** Q.H. Abbasi, M.U. Rehman, K. Qaraqe and A. Alomainy (Editors)
- Volume 67 **Managing the Internet of Things: Architectures, theories and applications** J. Huang and K. Hua (Editors)
- Volume 68 **Advanced Relay Technologies in Next Generation Wireless Communications** I. Krikidis and G. Zheng
- Volume 69 **5G Wireless Technologies** A. Alexiou (Editor)
- Volume 70 **Cloud and Fog Computing in 5G Mobile Networks** E. Markakis, G. Mastorakis, C.X. Mavromoustakis and E. Pallis (Editors)
- Volume 71 **Understanding Telecommunications Networks, 2nd Edition** A. Valdar
- Volume 72 **Introduction to Digital Wireless Communications** Hong-Chuan Yang
- Volume 73 **Network as a Service for Next Generation Internet** Q. Duan and S. Wang (Editors)
- Volume 74 **Access, Fronthaul and Backhaul Networks for 5G & Beyond** M.A. Imran, S.A.R. Zaidi and M.Z. Shakir (Editors)
- Volume 76 **Trusted Communications with Physical Layer Security for 5G and Beyond** T.Q. Duong, X. Zhou and H.V. Poor (Editors)

- Volume 77 **Network Design, Modelling and Performance Evaluation** Q. Vien  
Volume 78 **Principles and Applications of Free Space Optical Communications**  
A.K. Majumdar, Z. Ghassemlooy, A.A.B. Raj (Editors)
- Volume 79 **Satellite Communications in the 5G Era** S.K. Sharma, S. Chatzinotas and  
D. Arapoglou
- Volume 80 **Transceiver and System Design for Digital Communications, 5th Edition**  
Scott R. Bullock
- Volume 81 **Applications of Machine Learning in Wireless Communications** R. He and  
Z. Ding (Editors)
- Volume 83 **Microstrip and Printed Antenna Design, 3rd Edition** R. Bancroft  
Volume 84 **Low Electromagnetic Emission Wireless Network Technologies: 5G and  
beyond** M.A. Imran, F. Hélot and Y.A. Sambo (Editors)
- Volume 86 **Advances in Communications Satellite Systems Proceedings of the 36th  
International Communications Satellite Systems Conference (ICSSC-2018)**  
I. Otung, T. Butash and P. Garland (Editors)
- Volume 89 **Information and Communication Technologies for Humanitarian Services**  
M.N. Islam (Editor)
- Volume 92 **Flexible and Cognitive Radio Access Technologies for 5G and Beyond**  
H. Arslan and E. Başar (Editors)
- Volume 93 **Antennas and Propagation for 5G and Beyond** Q. Abbasi, S.F. Jilani,  
A. Alomainy and M.A. Imran (Editors)
- Volume 95 **ISDN applications in Education and Training** R. Mason and P.D. Bacsich

*This page intentionally left blank*

# The Nine Pillars of Technologies for Industry 4.0

Edited by

Wai Yie Leong, Joon Huang Chuah and Boon Tuan Tee

The Institution of Engineering and Technology



Published by The Institution of Engineering and Technology, London, United Kingdom

The Institution of Engineering and Technology is registered as a Charity in England & Wales (no. 211014) and Scotland (no. SC038698).

© The Institution of Engineering and Technology 2021

First published 2020

This publication is copyright under the Berne Convention and the Universal Copyright Convention. All rights reserved. Apart from any fair dealing for the purposes of research or private study, or criticism or review, as permitted under the Copyright, Designs and Patents Act 1988, this publication may be reproduced, stored or transmitted, in any form or by any means, only with the prior permission in writing of the publishers, or in the case of reprographic reproduction in accordance with the terms of licences issued by the Copyright Licensing Agency. Enquiries concerning reproduction outside those terms should be sent to the publisher at the undermentioned address:

The Institution of Engineering and Technology  
Michael Faraday House  
Six Hills Way, Stevenage  
Herts, SG1 2AY, United Kingdom

[www.theiet.org](http://www.theiet.org)

While the authors and publisher believe that the information and guidance given in this work are correct, all parties must rely upon their own skill and judgement when making use of them. Neither the authors nor publisher assumes any liability to anyone for any loss or damage caused by any error or omission in the work, whether such an error or omission is the result of negligence or any other cause. Any and all such liability is disclaimed.

The moral rights of the authors to be identified as authors of this work have been asserted by them in accordance with the Copyright, Designs and Patents Act 1988.

#### **British Library Cataloguing in Publication Data**

A catalogue record for this product is available from the British Library

**ISBN 978-1-83953-005-0 (hardback)**

**ISBN 978-1-83953-006-7 (PDF)**

Typeset in India by MPS Limited

Printed in the UK by CPI Group (UK) Ltd, Croydon



---

# Contents

---

<b>About the editor</b>	<b>xix</b>
<b>Foreword</b>	<b>xxi</b>
<b>1 The Nine Pillars of technology for Industry 4.0</b>	<b>1</b>
<i>Joon Huang Chuah</i>	
1.1 Introduction	1
1.2 The Nine Pillars	2
1.2.1 Autonomous robots	3
1.2.2 Simulation	7
1.2.3 Horizontal and vertical system integration	10
1.2.4 Industrial internet of things	11
1.2.5 Cybersecurity	13
1.2.6 Cloud computing	14
1.2.7 Additive manufacturing	16
1.2.8 Augmented reality	17
1.2.9 Big data and data analytics	18
1.3 Conclusions	19
References	20
<b>2 Industry 4.0: the next frontier and its technological impacts, the role of global standardisation and sustainable development</b>	<b>23</b>
<i>Alex Looi Tink Huey</i>	
2.1 Global standardisation in Industry 4.0	23
2.1.1 Technological impacts of Industry 4.0	25
2.2 Industry 4.0 and sustainable development	30
References	32
<b>3 Industrial revolution 4.0 – big data and big data analytics for smart manufacturing</b>	<b>35</b>
<i>Yu Seng Cheng, Joon Huang Chuah and Yizhou Wang</i>	
3.1 Smart manufacturing and cyber-physical system	35
3.2 Overview of big data	38
3.2.1 Data-driven smart manufacturing	41
3.2.2 Data lifecycle	44

3.3	Big data analytics	48
3.3.1	Text analytics	48
3.3.2	Audio analytics	51
3.3.3	Video analytics	52
3.3.4	Social analytics	52
3.3.5	Predictive analytics	54
3.3.6	Big data advanced analytics for smart manufacturing	56
	References	57
4	<b>Virtual and augmented reality in Industry 4.0</b>	<b>61</b>
	<i>Mohankumar Palaniswamy, Leong Wai Yie and Bhakti Yudho Suprpto</i>	
4.1	Industry 4.0	61
4.1.1	Augmented reality and virtual reality	64
4.2	AR and VR in Industry 4.0	65
4.3	Conclusion	73
	References	73
5	<b>Cyber security: trends and challenges toward Industry 4.0</b>	<b>79</b>
	<i>Boon Tuan Tee and Lim Soon Chong Johnson</i>	
5.1	Introduction	81
5.2	Recent trends	81
5.2.1	Web servers	81
5.2.2	Cloud computing	81
5.2.3	Advanced persistent threat	81
5.2.4	Smart mobile phones	82
5.2.5	New internet protocol	82
5.2.6	Code encryption	82
5.2.7	Social engineering	82
5.2.8	Social media exploits	83
5.2.9	Bad universal serial bus (USB) attack	83
5.2.10	Air-gapped system attack	83
5.3	Cyber security solution technologies	84
5.3.1	Vulnerability scanners	84
5.3.2	Intrusion prevention system	84
5.3.3	Intrusion detection system	85
5.4	Challenges	85
5.4.1	User privacy	85
5.4.2	Cyber security risk management	87
5.4.3	Digital forensics	88
5.5	Conclusions	89
	References	89

<b>6</b>	<b>The role of IIoT In smart Industries 4.0</b>	<b>91</b>
	<i>Mohsen Marjani, Noor Zaman Jhanjhi, Ibrahim Abaker Targio Hashem and Mohammad T. Hajibeigy</i>	
6.1	Introduction	91
6.1.1	Internet of Things means what?	92
6.1.2	Journey of IoT to IIoT to Industry 4.0	92
6.1.3	Difference between IoT and IIoT?	93
6.2	Overview of IoT in smart industrial 4.0	93
6.2.1	State-of-the-art industrial Internet of Things	96
6.2.2	Applications of IIoT for smart industries 4.0	98
6.3	Use cases of IIoT for smart industries 4.0	101
6.3.1	Automotive navigation system	102
6.3.2	Supply-chain management and optimization	102
6.3.3	Asset tracking and optimisation	102
6.3.4	Driving enterprise transformation	102
6.3.5	Connecting the form to the Cloud	103
6.4	The current uses and limitations of IIoT in smart industry 4.0	103
6.4.1	Connectivity	103
6.4.2	Autonomous power	103
6.4.3	IoT hardware	103
6.4.4	Security	104
6.5	Open research issues and challenges of smart industries 4.0	104
6.5.1	Interoperability	105
6.5.2	Big IIoT data analytics	105
6.5.3	Data security	106
6.5.4	Data quality	106
6.5.5	Visualisation	107
6.5.6	Privacy issues	107
6.5.7	Investment issues	108
6.5.8	Servitised business models	108
6.6	Future directions of IIoT in smart industries 4.0	109
6.7	Conclusion	111
	Acknowledgement	112
	References	112
<b>7</b>	<b>Simulation in the 4th Industrial Revolution</b>	<b>117</b>
	<i>Chee Pin Tan and Wen-Shyan Chua</i>	
7.1	Introduction	117
7.2	Types of simulation	117
7.2.1	Simulation of a physical system	118
7.2.2	Interactive simulation	126
7.3	Benefits of simulation	131
7.3.1	Predictive maintenance	131
7.3.2	Prediction	132

x	<b>5</b> <i>The nine pillars of technologies for Industry 4.0</i>	
	<b>4</b> 7.3.3 Design, development, and training	133
	References	134
<b>8</b>	<b>The role of artificial intelligence in development of smart cities</b>	<b>137</b>
	<i>Rahulraj Singh Kler and Joon Huang Chuah</i>	
	<b>1</b> 8.1 Industry 4.0 and smart cities	137
	8.2 Artificial intelligence	139
	8.2.1 Machine vision and object recognition	141
	8.2.2 Natural language processing	146
	8.2.3 Cognitive computing	148
	8.3 Role of AI in smart cities	149
	8.3.1 Safety and surveillance	149
	8.3.2 Healthcare	154
	8.3.3 Big data	159
	8.3.4 Transportation and infrastructure	162
	8.3.5 Energy planning and management	166
	8.4 Opportunities and risks	168
	References	170
<b>4</b> <b>9</b>	<b>How industrial robots form smart factories</b>	<b>177</b>
	<i>Yaser Sabzehmeidani</i>	
	<b>1</b> 9.1 Industry 4.0 and industrial robots	177
	9.2 Smart factories	180
	9.2.1 Efficiency and productivity	181
	9.2.2 Safety and security	182
	9.2.3 Flexibility	183
	9.2.4 Connectivity	184
	9.3 Internet of Things	184
	9.4 Artificial intelligence	186
	9.5 Smart materials and 3D printing	188
	References	190
<b>10</b>	<b>Integration revolution: building trust with technology</b>	<b>193</b>
	<i>Ishaan Gera and Seema Singh</i>	
	10.1 Introduction	193
	10.2 Objectives and methodology	195
	10.3 Evolution of the blockchain	195
	10.3.1 Closed and open systems	197
	10.4 Trust economies	198
	10.4.1 Production	199
	10.4.2 Organisation	200
	10.4.3 Services	202
	10.4.4 Finance	203

3	10.4.5 Governance	206
	10.5 Utilising the blockchain	208
	10.6 Conclusion	211
	References	213
	<b>11 System integration for Industry 4.0</b>	<b>215</b>
	<i>Nseabasi Peter Essien, Uduakobong-Aniebiat Okon, and Peace Asuquo Frank</i>	
	11.1 Introduction	215
	11.2 Application of system integration in VLS database replication design	216
	11.3 Database replication	216
	11.3.1 Root of replication	216
	11.4 Virtual learning system replication policy	224
	11.4.1 Testing of experiment II (transition and analysis) replication testing	225
	11.4.2 Configuration on master at command prompt	226
	11.4.3 Configuration on slave at command prompt	226
	11.4.4 Hardware and software requirement for replication	226
	11.5 Conclusion	229
	References	230
1	<b>12 Additive manufacturing toward Industry 4.0</b>	<b>233</b>
	<i>Puvanavar A. Perumal and Kalvin Paran Untol</i>	
	12.1 AM in various industries	233
	12.1.1 Automotive industries and suppliers	234
	12.1.2 Aerospace industries	235
	12.1.3 Toy industry	235
	12.1.4 Consumer goods	235
	12.1.5 Foundry and casting	236
	12.1.6 Medical	236
	12.1.7 Architecture and landscaping	237
	12.2 Different materials used in AM	237
	12.2.1 Plastics	238
	12.2.2 Metals	239
	12.2.3 Ceramics	239
	12.2.4 Composites	240
	12.3 Global evolution of AM	240
	12.3.1 Early stages	241
	12.3.2 Growth stages	241
	12.3.3 Maturity stages	241
	12.4 Future direction of AM	242
	12.5 Conclusion	242
	References	243

<b>13</b>	<b>Cloud computing in Industrial Revolution 4.0</b>	<b>245</b>
	<i>Mohankumar Palaniswamy and Leong Wai Yie</i>	
13.1	Cloud computing	245
13.1.1	Benefits of cloud computing	246
13.1.2	Types of cloud computing	247
13.1.3	Types of cloud services	248
13.2	Fog computing	248
13.3	Edge computing	248
13.4	Security and privacy issues	249
13.5	Cloud computing in Industrial Revolution 4.0	251
13.6	Cloud computing in the communication sector	254
13.7	Cloud computing in healthcare sector	255
13.8	Scholarly articles in cloud computing	255
13.9	Conclusion	257
	References	258
<b>14</b>	<b>Cybersecurity in Industry 4.0 context: background, issues, and future directions</b>	<b>263</b>
	<i>Haqi Khalid, Shaiful Jahari Hashim, Sharifah Mumtazah Syed Ahmad, Fazirulhisyam Hashim and Muhammad Akmal Chaudary</i>	
14.1	Introduction: background and motivation	263
14.2	I4.0 cybersecurity characterizations	265
14.2.1	Cybersecurity vulnerabilities	265
14.2.2	Cybersecurity threats	266
14.2.3	Cybersecurity risks	267
14.2.4	Cybersecurity countermeasures	269
14.3	I4.0 security principles	270
14.3.1	Confidentiality	270
14.3.2	Integrity	270
14.3.3	Availability	273
14.3.4	Authenticity	273
14.3.5	Nonrepudiation	273
14.3.6	Privacy	274
14.4	I4.0 system components	274
14.4.1	Cloud computing	275
14.4.2	Big data	276
14.4.3	Interoperability and transparency	276
14.4.4	Blockchain (distributed ledgers)	278
14.4.5	Software-defined network	279
14.4.6	Multi-factor authentication	280
14.5	Open issues	283
14.5.1	Fog computing issues	283
14.5.2	Big data issues	283
14.5.3	Interoperability issues	285



14.5.4 GraphQL issues	285
14.5.5 Blockchain issues	286
14.5.6 SDN issues	286
14.5.7 Kerberos issues	287
14.5.8 Two-factor authentication issues	291
14.5.9 Three-factor authentication issues	293
14.6 Future directions	295
14.6.1 Directions to the developer/designer	295
14.6.2 Directions to researchers	295
14.6.3 Directions to industries/factories	297
14.7 Conclusion	298
References	298
<b>15 IoT-based data acquisition monitoring system for solar photovoltaic panel</b>	<b>309</b>
<i>Ranjit Singh Sarban Singh, Muhammad Izzat bin Nurdin, Wong Yan Chiew and Tan Chee Fai</i>	
15.1 System design and development	310
15.1.1 Conceptual TC sensors placement, system design, integration and installation	310
15.1.2 Hardware: sensors system design, integration and installation	311
15.2 Software design and development	315
15.2.1 Embedded software design integration – Raspberry Pi Zero Wireless hardware system and website	316
15.2.2 Embedded software design	316
15.3 Results and discussion	318
15.3.1 Hardware system design and development	318
15.3.2 Embedded software design and development	321
15.3.3 Cloud/database monitoring system	322
15.3.4 IoT-based data acquisition monitoring system webpage – localhost	327
15.4 Conclusion	331
Acknowledgement	331
<b>16 Internet of Things (IoT) application for the development of building intelligent energy management system</b>	<b>333</b>
<i>Boon Tuan Tee and Md Eirfan Safwan Md Jasman</i>	
16.1 Introduction	333
16.2 Building indoor environment	334
16.3 Building energy management	336
16.4 IoT approach for data and information collection	337
16.4.1 Indoor environment monitoring	337
16.4.2 Energy performance assessment	342
16.5 Conclusion	344
References	345



<b>17 Expert fault diagnosis system for building air conditioning mechanical ventilation</b>	<b>347</b>
<i>Chee-Nian Tan, CheeFai Tan, Ranjit Singh Sarban Singh and Matthias Rauterberg</i>	
17.1 Introduction	348
17.2 Overall system description	350
17.2.1 Literature review	351
17.2.2 Knowledge acquisition	351
17.2.3 Design	351
17.2.4 Testing and validation	353
17.2.5 Maintenance	353
17.3 System development	353
17.3.1 Development of the KBS	354
17.3.2 Create a rule	357
17.3.3 Goal	357
17.3.4 User interface	359
17.3.5 KAL view debugger window	362
17.3.6 Find and replace window	363
17.3.7 Rule window	364
17.4 Summary	366
References	366
<b>18 Lean green integration in manufacturing Industry 4.0</b>	<b>369</b>
<i>Puvanasvaran A. Perumal</i>	
18.1 Green	369
18.2 Lean green	370
18.3 Integration of lean and green	371
18.4 Lean green needs	371
18.5 Lean green benefits	373
18.6 Lean green disadvantages	375
18.7 Elements integrate lean green	376
18.8 Lean green tools	377
18.8.1 Production Preparation Process (3P)	378
18.9 Lean enterprise supplier networks	379
18.10 Lean green application	382
18.11 Lean green standards	382
18.12 Chapter summary	385
References	385
<b>19 Lean government in improving public sector performance toward Industry 4.0</b>	<b>387</b>
<i>Puvanasvaran A. Perumal</i>	
19.1 People development system	387

	4	
19.2	Lean implementation in public sector	388
19.3	Performance measurement in improving public sector	390
19.4	Problems of lean implementation in public sector	392
19.5	Conclusion	394
	References	395
<b>20</b>	<b>Lean dominancy in service Industry 4.0</b>	<b>399</b>
	<i>Puvanasvaran A. Perumal</i>	
20.1	Definition	399
20.2	Transformation in lean services	400
20.3	Eight wastes of lean	401
20.4	Lean tools in service industry	404
20.5	Critical elements in lean service	404
	20.5.1 Leadership and management	404
	20.5.2 Customer focus	404
	20.5.3 Empowering employment	405
	20.5.4 Quality	405
	20.5.5 Challenges in lean services	407
20.6	Application of lean in services	407
	20.6.1 Lean hotel	407
	20.6.2 Lean in hospital	411
	20.6.3 Lean construction	413
	20.6.4 Lean office	418
20.7	Lean in service versus lean in manufacturing	424
	20.7.1 Lean manufacturing	427
20.8	Chapter summary	428
	References	428
<b>21</b>	<b>Case study: security system for solar panel theft based on system integration of GPS tracking and face recognition using deep learning</b>	<b>431</b>
	<i>Bhakti Yudho Suprpto, Meydie Tri Malindo, Muhammad Iqbal Agung Tri Putra, Suci Dwijayanti and Leong Wai Yie</i>	
21.1	Introduction	431
21.2	Method	432
	21.2.1 Face recognition using deep learning	432
	21.2.2 GPS tracking	434
21.3	Results and discussion	434
	21.3.1 Deep learning model for face recognition system	434
	21.3.2 Offline test	440
	21.3.3 Online test	440
	21.3.4 GPS tracking test	442
	21.3.5 GPS tracking: communication system	444
	21.3.6 GPS tracking: real-time system test	446

21.4	<b>Conclusion</b>	452
	References	452
<b>22</b>	<b>Project Dragonfly</b>	<b>455</b>
	<i>Ting Rang Ling, Lee Soon Tan, Sing Muk Ng and Hong Siang Chua</i>	
22.1	Introduction	455
	22.1.1 Overview	455
	22.1.2 Air quality	456
	22.1.3 Water quality	456
22.2	Related research	456
	22.2.1 IoT concept	456
	22.2.2 Air quality	457
22.3	Methodology	467
	22.3.1 Overview	467
	22.3.2 System setup	468
	22.3.3 Quadcopter	468
	22.3.4 Hardware modules	468
22.4	Results	473
	22.4.1 Dragonfly	473
	22.4.2 Project Dragonfly Software	473
22.5	Conclusion	476
	References	476
<b>23</b>	<b>Improving round-robin through load adjusted-load informed algorithm in parallel database server application</b>	<b>481</b>
	<i>Nseabasi Peter Essien, Uduakobong-Aniebiat Okon and Peace Asuquo Frank</i>	
23.1	Introduction	481
23.2	Application of LBAM 4.0	482
23.3	Cluster database system	483
	23.3.1 Methodology	483
23.4	Experimentation	487
	23.4.1 Hardware and software requirement for load balance approach model	487
23.5	Algorithm description	488
	23.5.1 Round-robin algorithm	488
	23.5.2 Translation of round-robin algorithm into PHP algorithm	488
23.6	Load adjusted-load informed algorithm	490
	23.6.1 Translation of load adjusted-load informed algorithm into PHP algorithm (adopted from Job Informed)	491
	23.6.2 Implementation (program extract PHP)	492
23.7	Recommendation	496
23.8	Conclusion	496
	References	497

<b>24</b>	<b>1</b>	<b>5G network review and challenges</b>	<b>499</b>
		<i>Wei Siang Hoh, Bi-Lynn Ong, Wai Yie Leong and Si-Kee Yoon</i>	
24.1		5G network overview	499
	24.1.1	5G network use cases	500
	24.1.2	5G network architecture	502
24.2		5G network deployment	504
	24.2.1	Deployment options for NSA and SA	504
	24.2.2	Spectrum of 5G network	507
	24.2.3	5G technology and technical regulations	510
24.3		Key challenges of 5G network	514
	24.3.1	Small cell deployment challenges	515
	24.3.2	Fibre backhaul network deployment challenges	516
	24.3.3	5G user privacy challenges	517
24.4		Summary	518
		References	518
<b>25</b>	<b>1</b>	<b>Industry 4.0 and SMEs</b>	<b>521</b>
		<i>Habtom Mebrahtu</i>	
25.1		Introduction	521
25.2		Opportunities and challenges of adopting Industry 4.0 by SMEs	523
	25.2.1	Opportunities	523
	25.2.2	Challenges	524
25.3		Readiness of SMEs to adopt Industry 4.0	525
	25.3.1	PwC Industry 4.0 self-assessment tool	525
	25.3.2	SoRF Smart Factory assessment tool	527
	25.3.3	WMG Industry 4.0 assessment tool	528
25.4		Helping SMEs to adopt Industry 4.0	531
	25.4.1	GrowIn 4.0	532
	<b>4</b>	25.4.2 Industry 4.0 readiness/awareness tool	533
		25.4.3 Benefits identification	534
25.5		Summary	538
		References	539
		<b>Index</b>	<b>541</b>

*This page intentionally left blank*

---

## About the editors

---

**Wai Yie Leong** is the Chairperson of The Institution of Engineering and Technology (Malaysia Local Network) and Vice President of The Institution of Engineers, Malaysia (IEM). She specializes in sensing and wireless communications and medical signal processing research including wireless sensor networks, wireless communications, and brain signal processing for signal conditioning and classification in various EEG-based mental tasks. She received the Women Engineer of the Year award in 2018, the IEM Presidential of Excellence Award in 2016, and ASEAN Meritorious Award in Science and Technology 2017. She holds a Ph.D. in Electrical Engineering from The University of Queensland, Australia.

**Joon Huang Chuah** lectures at the Department of Electrical Engineering, University of Malaya, Malaysia and is the Head of VLSI and Image Processing (VIP) Research Group. He specialises in artificial intelligence, image processing and integrated circuit design. He is the Principal Journal Editor of the Institution of Engineers, Malaysia. He received his B.Eng. from the Universiti Teknologi Malaysia, M.Eng. from the National University of Singapore, MPhil in Technology Policy from the Cambridge Judge Business School, and PhD from the University of Cambridge.

**Boon Tuan Tee** is an Associate Professor at the Faculty of Mechanical Engineering, Universiti Teknikal Malaysia Melaka, Malaysia. His research focuses on energy management system and green technology. He is a Professional Technologist (Green Technology) registered under Malaysia Board of Technologists. His other professional certifications include Certified Energy Manager under ASEAN Energy Management System (AEMAS) and Certified Professional in Measurement & Verification from Malaysia Greentech. He has been a member of the IET since 2015. He holds a Ph.D. degree in Engineering from University of Cambridge, UK.

*This page intentionally left blank*



---

## Foreword

---

Industry 4.0 refers to the current trend of automation and data exchange in manufacturing technologies, also called Intelligent or Smart Manufacturing. There is an increasing number of organizations and countries where Industry 4.0 is becoming adopted including the United Kingdom (Industry 4.0 and the work around 4IR), the United States, Japan, China and the European Union. Several research organizations, with a leading role for the Fraunhofer Institute, are pushing a reference architecture model for secure data sharing based on standardized communication interfaces. The nine pillars of technology that are supporting this transition include: the internet of things (IoT), cloud computing, autonomous and robotics systems, big data analytics, augmented reality, cybersecurity, simulation, system integration and additive manufacturing. A key role is played by Industrial IoT with its many components (platforms, gateways, devices) but many more technologies play a role in this process including cloud, fog and edge computing, advanced data analytics, innovative data exchange models, artificial intelligence, machine learning, mobile and data communication and network technologies, as well as robotics, sensors and actuators. Over the IoT, cyber-physical systems communicate and cooperate with each other and with humans in real-time both internally and across organizational services in the value chain. Within smart factories, cyber-physical systems monitor physical processes, create a virtual copy of the physical world and make decentralized decisions. The aim of this edited book is to focus on the nine pillars of technology including innovative research, challenges, strategies and case studies.

Advances in science and technology continuously support the development of industrialization all over the world. The First Industrial Revolution used water and steam power to mechanize production, the Second used electric power to create mass production and the Third used automation for the manufacturing line. Now a Fourth Industrial Revolution, the digital revolution, is characterized by a fusion of technologies that is blurring the lines between the physical, digital and biological spheres. There are three reasons why today's transformations represent not merely a prolongation of the Third Industrial Revolution but rather the arrival of a Fourth and distinct one: velocity, scope and systems impact. The speed of current breakthroughs has no historical precedent. When compared with previous industrial revolutions, the Fourth is evolving at an exponential rather than a linear pace. Moreover, it is disrupting almost every industry in every country. And, the breadth and depth of these changes herald the transformation of entire systems of production, management and governance. The design principles of Industry 4.0 such as virtualization, interoperability, decentralization, service-oriented approaches,

real-time capabilities and modularity all play a key role in the radical changes facing industry. In this book series, we describe the advantages of intelligent manufacturing systems and discuss how they will benefit the manufacturing industry by increasing productivity, competitiveness and profitability. (Benefits: enhanced productivity through optimization and automation, real-time, better quality products, sustainability, personalization and customization for consumers, and improved scalability and agility.)

In this book series, the nine pillars of technology that are supporting this transformation have been introduced: the IoT, cloud computing, autonomous and robotics systems, big data analytics, augmented reality, cybersecurity, simulation, system integration and additive manufacturing.

Technologies and Industry 4.0 are about reducing complexity and processes and add value. However, while business processes are changing rapidly, industries and manufacturers are struggling to exploit the full potential of digitization. From both a strategic and technological perspective, the Industry 4.0 roadmap visualizes every further step on the route towards an entirely digital enterprise. Many case studies have been discussed in this book series, which aims to benefit and create impact to industry players, scientists, academicians, researchers and manufacturers.

## Virtual and augmented reality in Industry 4.0

*Mohankumar Palaniswamy<sup>1</sup>, Leong Wai Yie<sup>2</sup> and  
Bhakti Yudho Suprpto<sup>3</sup>*

There was a period in our history, where industrial works used to happen manually by labors at their houses. Later, it started to happen in industries with the help of machines. The process of transferring a labor-based agrarian economy to a machine-based is called as Industrial Revolution. This transformation initially started in Great Britain during the eighteenth century, followed by European countries such as Belgium, Germany, and France and slowly started to spread across the globe. Industrial revolution was the result of development in knowledge, equipment, machineries, technologies, and tools, especially social and cultural acceptance from people and benefits arising from it. Earlier, iron, steel, and wood were the primary raw materials used widely. Steam engine, combustion engine, and electricity were available at that time. Later, due to industrial revolution, steamship, locomotive, telegraph, and radio were developed. The idea of using science for development of humankind in the name of industry or factory started taking roots.

The economic transformation that took place in Western countries from 1780 to 1850 was termed as the First Industrial Revolution [1]. Realizing the importance of science and technology, with more research, second and third industrial revolutions took place. The duration of every industrial revolution was around five decades. This was the period of mass production.

### 4.1 Industry 4.0

There is a general belief that first industrial revolution was about steam and water, second industrial revolution was about steel, and third industrial revolution was about electricity, internet, and automobiles. In contrast, fourth industrial revolution has just begun [2] (Figure 4.1). The term Industry 4.0 was put forward by the German government in 2011 at Hanover fair [1]. The term Industry 4.0 is also called as “Industrial Internet,” “Digital Factory,” “Intelligent Factory,” “Factory of Future,”

<sup>1</sup>School of Engineering, Taylor’s University, Subang Jaya, Malaysia

<sup>2</sup>Faculty of Engineering and Built Environment, MAHSA University, Jenjarom, Malaysia

<sup>3</sup>Department of Electrical Engineering, Universitas Sriwijaya, Palembang, Indonesia

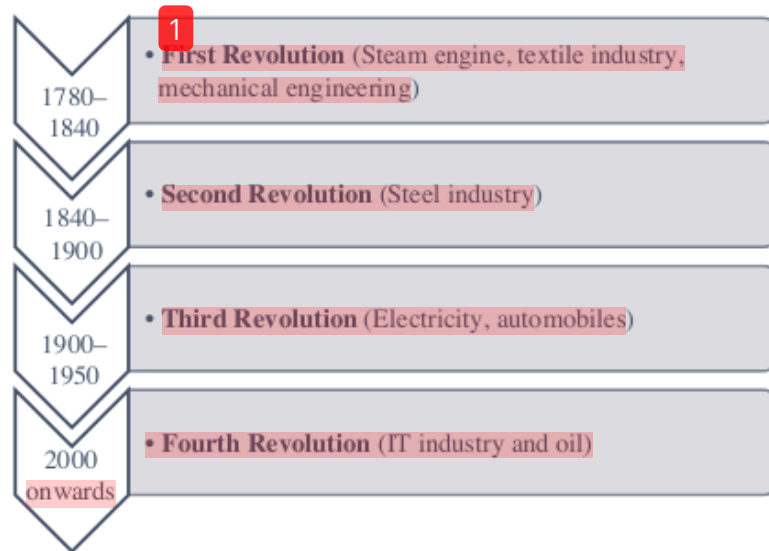

Figure 4.1 Industrial revolutions

and “Smart Manufacturing” by professionals [3]. Industry 4.0 or Fourth Industrial Revolution is based on internet of things (IoT), internet of services (IoS), cyber-physical systems (CPSs), and interaction and exchange of data between humans (C2C), machines (M2M), and between humans and machines (C2M) [4,5]. As the Industry 4.0 is still in its early stage, several research organizations, universities, and companies try to develop a fully automatic internet-based industry or factory, such as Siemens Amberg plant in Germany, where the 108,000 square foot factory can run and assemble components without any human input [6]. Industry 4.0 has several components such as cloud computing, CPS, IoT, system integration, additive manufacturing (AM), augmented reality (AR), virtual reality (VR), data analysis, AI robots, etc. (Figure 4.2).

Cloud computing – production-related data will be uploaded and shared in the cloud technology, where the receiving and reaction time will be few milliseconds. CPS – an advanced IT tool, which has a big storage capacity and high transmission speed. CPS provides solutions based on software-related applications while reducing the role of hardware or mechanical devices [8]. Smart products are components of CPS. It can connect between both the real and virtual world [9]. IoT – modern manufactures thought how to convert their product into a long-term revenue-providing service. It led them to IoT. IoT is the fundamental integration of smart devices, which are parts of the smart projects. For example, in a smart house, television, gaming console, and air conditioner that have an IP address can be connected to the IoT [10] and can be accessed from anywhere. Otis supplies elevators with sensors to the public, which send data to their cloud. This data is analyzed and Otis offers maintenance packages, which again generates extra revenue [11] (refer Figure 4.3). System integration – in Industry 4.0, several departments under a factory or several factories under same company become organized and interconnected with universal data integration. Additive manufacturing (AM) – with Industry 4.0, 3D printing will be widely used to manufacture customized products.





Figure 4.2 Components of Industry 4.0 [7]

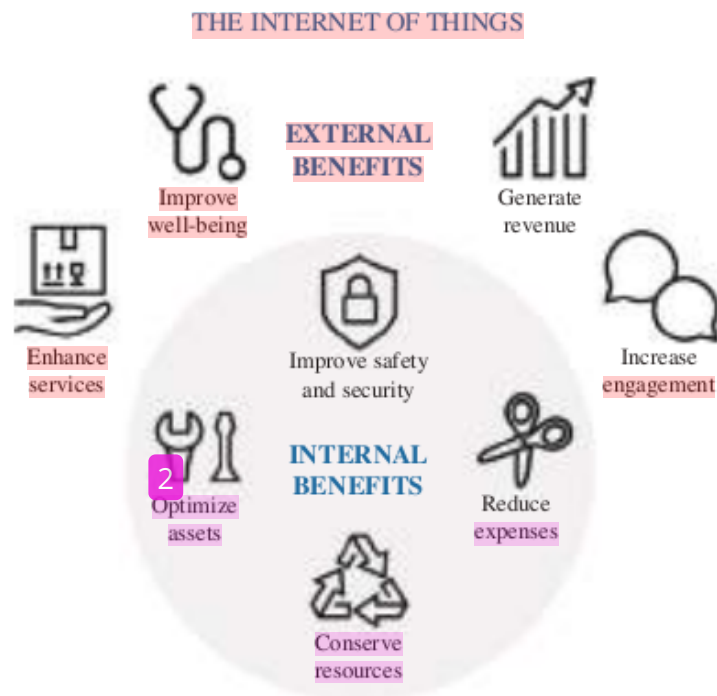

Figure 4.3 Internet of things [12]

AR, VR – AR- and VR-based services offer workers and operators to improve decision-making and limiting the work procedures. Data analysis – collecting and indexing data from different sources will become default in industries to support real-time decision-making. AI robots – robots will start to work with each other safely along with or without human intervention.

### 2 4.1.1 Augmented reality and virtual reality

The human and machine work interference in industry should be flexible and adaptive [13]. Because of this, several industries started to adopt using AR and VR to train their workers [14]. With this training, they can (i) speed up the work or reconfigure the work, (ii) support operators, (iii) execute augmented virtuality (AV) training for compiling or constructing parts, (iv) administer depository or stockroom effectively, (v) support diagnostics in the assembly, and (vi) minimize the risk in the work setting [15]. The key technologies on AV used in the industries are display interaction, tracking positioning and registration, human–computer interaction, object detection and recognition, calibration, model rendering, analysis on 3D space, and collision detection [16–19].

Attempts on 3D simulation dates to 1930, when Stanley G. Weinbaum used a pair of goggles to watch his movie “Pygmalion’s Spectacles” to undergo holographic experience. Latter AR was first introduced by computer pioneer Ivan Sutherland in 1968 [20]. He used a head mounted display (HMD) device, which was connected to a stereoscopic display from a computer. AR is a technology that overlays virtual image or information in real world. For example, adding an image or text to user display virtually in the real environment (RE). Here, RE represents surrounding of the user. The recent Pokemon GO game is a good example of AR usage [21]. In contrast, virtual environment (VE) is the surrounding completely generated by computer, where the user will not have any contact with the RE [22] (Figure 4.4). VR is a synthetic world, which may or may not look like a real world [23]. Initially, VR took over the world in 1990s by equipment such as Saga VR and Nintendo Virtual Boy. In the twenty-first century, using VR, people started to create a virtual representation of themselves called “Avatars.”

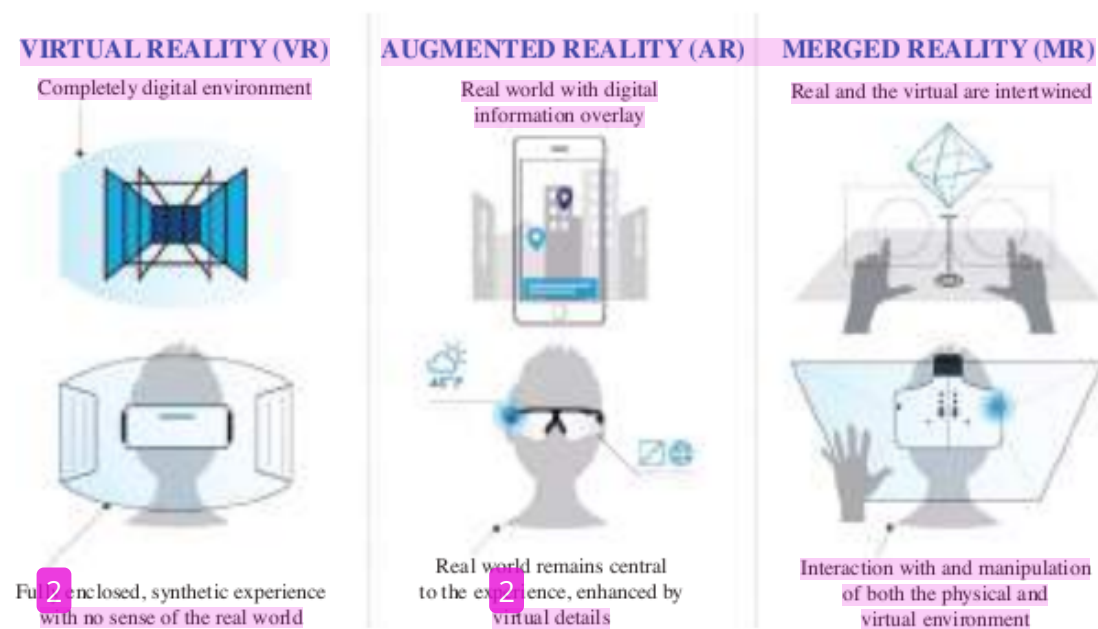

Figure 4.4 Difference between VR, AR, and MR [24]

#### 4.1.1.1 Programming libraries

There are several AV programming libraries used in the industries. Among them ARToolKit, ARTag, osgART, and Vuforia are commonly used. ARToolKit is an opensource tracking library. It is the most common tool used to develop AR. Hirokazu Kato first developed it in 1999. ARToolKit was further developed with ARTag. ARTag is used to simplify the virtual objects within real world. OsgART is a C++ cross-platform library. It compiles the tracking library with 3D library. Vuforia is an AR software-development kit for mobiles. It compiles computer vision, planar changes, and 3D objects in real time [25]. With the recent development of mixed reality (MR), AR and VR are more commonly used in industries to reduce their processing, training, and decision-making time. With this in mind, this chapter reviews the achievements of AR and VR, tools used for constructing reality, and their field of use in the recent times.

## 4.2 AR and VR in Industry 4.0

AR and VR are very commonly used in the manufacturing industries for the purpose of quality control in the product, training or teaching the new recruits, designing the workspace, customization according to client need, maintenance of factory, manufacturing items, and marketing.

Quality assessment, which is done in traditional method, consumes a lot of time. A conceptual idea proposed and validated by Federica Ferraguti *et al.*, found that AR can be used in quality control [26]. With their approach, an operator can directly see the product if it has reached the quality specifications or any further refinements required. Factories are run not only by humans but also with machines such as robots. New theory puts forward that VR can be used for human-machine collaboration for adaptive product engineering [27].

Not only in designing, production, and quality control of a product but also in marketing the product AR and VR can be used. A 2013 study on footwear marketing used AR and VR technologies for marketing. Morenilla *et al.* [28] developed a stereoscopic vision system based on 3D+ software and footwear design. A desktop computer operating Windows 7 with i5 processor, 4GB RAM, nVidia Quadro 600 graphic card, 3dVision pack, BENQ double-frequency LED 3D monitor, and CodeGear C++ RAD Studio 2007 were used to view the footwear. To interact with the footwear, a VR glove from 5DT was used. It had five sensors for flexion and two for rotation. This single glove replaces the job done by keyboard and mouse. Different positioning of finger gestures corresponds to different view (Figure 4.5). To capture the user or consumer and view him/her in AR, a scene-capturing camera, LG Webpro 2, was used. To locate the position of foot, IR camera from Nintendo console and emitting device comprised of four LED diodes were used (Figure 4.6). After calibration and processing, final output is viewed in the monitor in real time, where the consumer is real, and the shoe is virtually developed (Figure 4.7). Using this method, consumer can see himself or herself wearing the shoes virtually.





1

Figure 4.5 Glove gestures and the corresponding view [28]

Using AR and VR, an ergonomic workplace can be set up or ergonomics of the existing workplace can be found. Ceit ergonomic analysis application (CERAA) is used in mobile or with cave automatic virtual environment (CAVE), markers, Wii remotes, and assessment forms such as rapid entire body assessment (REBA), and rapid upper limb assessment (RULA) to find the office ergonomics [29,30].

AR is used in customization of an industry or factory, based upon the need. Using product manuals or descriptions in a PDF format is old fashioned. Recent 2019 studies incorporated AR by utilizing Unity 3D, Vuforia, HMD, and HoloLens to convert paper manuals into digital texts, signs, and graphical representations [31–33]. This method helps the operator to understand and use the manual easily [34]. AR and VR are used in designing a virtual workspace environment, where the operator or mechanic can understand how the parts are assembled [35,36]. Using AR and VR, remote maintenance is also possible [37,38]. VR is particularly used for industrial application training. Instead of onsite visit and consuming working hour, a virtual representation of the industry, warehouse, and its components is beneficial and valuable in training a fresher [39,40].

A 2019 study by Perez *et al.* [41] developed a VR of the industry, mimicking the same environment along with the robots to train the operators. Generally, robot is a mechanical structure with electronics, motors, controllers, and human-



Figure 4.6 AR prototype. (a) Scene-capturing camera, (b) IR camera, (c) computer with footwear design, (d) double-frequency LED monitor, and (e) IR LED diodes [28]



Figure 4.7 Final outcome [28]

machine interface (HMI). Perez *et al.* replaced this HMI with VR, which is connected to the robot. Their proposed system consists of two robots: a real and virtual, both controlled by same controller which was paired with VR (Figure 4.8). Sensors were connected to the real robot to obtain the pose and accuracy. To develop an identical workplace environment virtually, the workplace environment was initially

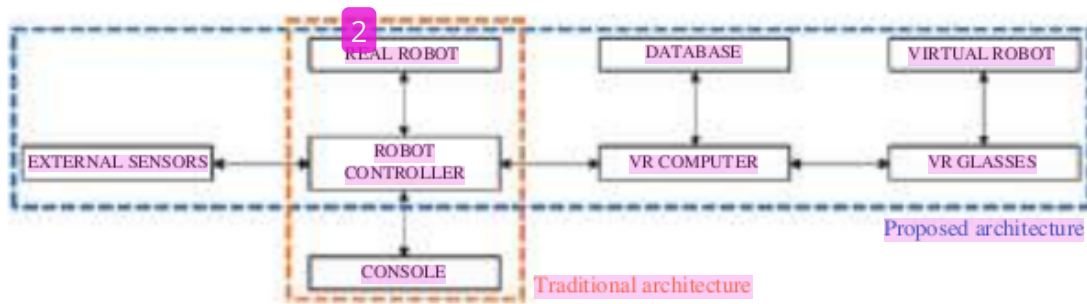

Figure 4.8 System architecture [41]

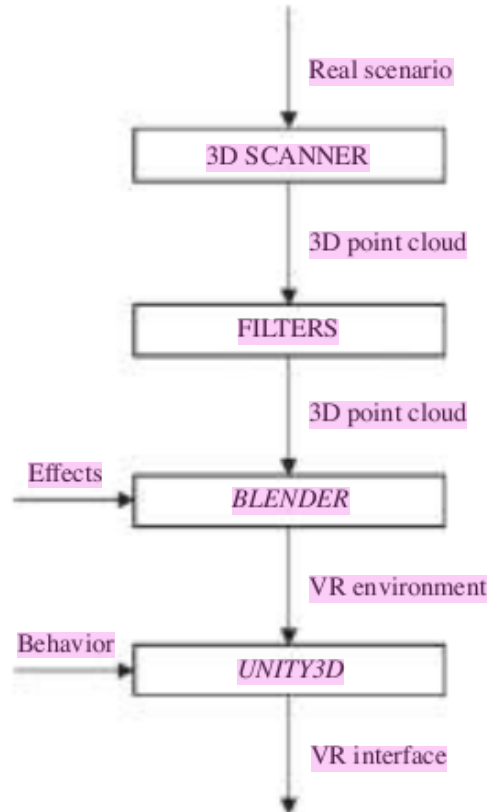

Figure 4.9 Process to develop VR interface [41]

scanned with FARO Focus3D HDR. The obtained 3D point cloud was processed with CloudCompare, modeled with Blender, and then processed with Unity3D to implement HMI (Figure 4.9). Using Oculus Rift and HTC Vive, the developed virtual was screened to operators for VR-simulated and VR-operated robot training (Figure 4.10). Twelve people underwent training and their feedback was recorded using questionnaire. They felt that VR training would increase efficiency of working environment.

AR, VR, and additive manufacturing are the most valuable aspects of aviation industry right now, as they play a major role in maintenance, detection of errors and safety in aircraft, and manufacturing small parts for small aircraft [42–44]. AR and



Figure 4.10 Training. (a) With real robot and (b) with virtual robot [41]

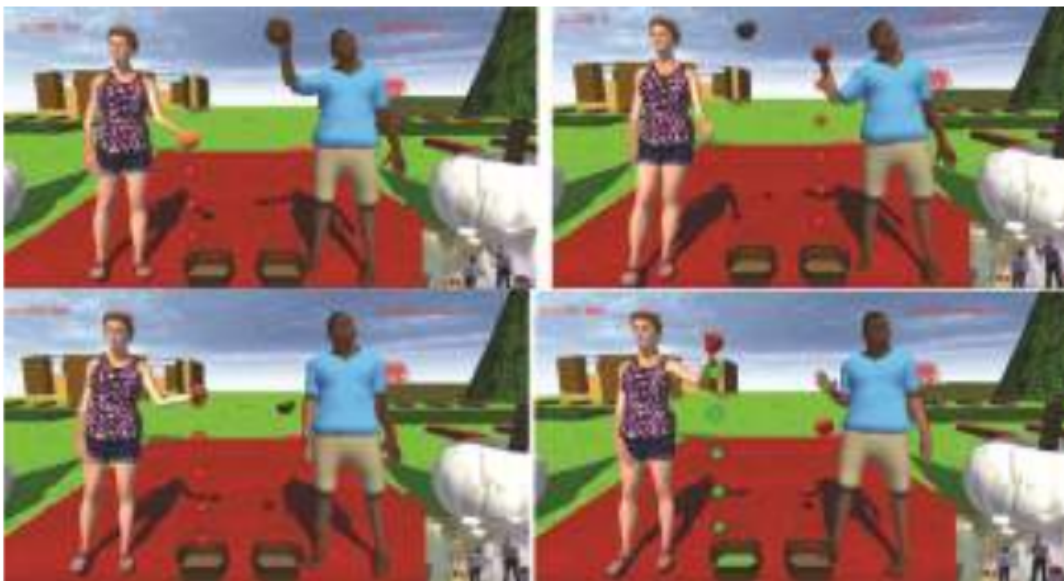

Figure 4.11 ReHabGame session, therapist, and patient [51]

VR technologies are used in construction and designing of buildings, machines, and robots. Particularly, AR is used in building information modeling (BIM) [45]. BIM information's provided in the software can be used during onsite visit. It can also be used latter for maintenance purpose. This in turn contributes to optimization and defect prevention [46–48].

AR and VR have revolutionized the medical field. They are utilized in analysis, rehabilitation, surgery, and treating phobias. Using leap motion sensor, IR camera, LED, and Unity 3D, hand motion analyses were performed [49]. Using Microsoft Kinect, Myo Armband, and Unity 3D, rehabilitation for stroke patients is provided. A game such as virtual environment is developed using Unity 3D, where the patients are supposed to play, such as throwing a ball or a fruit in a basket [50,51].

A 2018 study conducted by Esfahlani *et al.* [51] developed a VR-based game called “ReHabGame” to treat stroke patients. The game was developed using



Table 4.1 Augmented and virtual reality in different fields

Author	Year	Field	Technology	Tool	Sample	Objective
Lee <i>et al.</i> [48]	2011	Construction – Design	VR	ARToolKit, Microsoft Vision SDK, ROBOOP, Boost, V-Collide	–	Construct a mixed reality-based digital manufacturing environment
Morenilla <i>et al.</i> [28]	2013	Marketing	AR, VR	3D+, nVidia Quadro 600, 3D monitor, IR emitter, 5DT Virtual Glove	–	Implement AR, VR during footwear purchase
Fillatreau <i>et al.</i> [66]	2013	Industry – Maintenance	VR	Virtuose 6D Haptic Arm, CyberGlove II, ARTrack, VSL, C#	–	Framework for immersive checklist-based project reviews
Wang <i>et al.</i> [45]	2014	Construction – Maintenance	AR	Mobile, Tablet, HMD	–	Need for a structured methodology of fully integrated AR technology in BIM
Asgari <i>et al.</i> [46]	2017	Construction – Maintenance	VR	Leap Motion Controller, Myo, Nimble VR, Prio VR	–	Construction process optimization and defect prevention
Hui [40]	2017	Industry – Training	VR	Leap motion, Unity 3D, HMD, Gyroscope, Accelerometer, Nexus 6P mobile, Trinus	10	Compare experience and training effects in HMD-based and screen-based training
Giorgio <i>et al.</i> [27]	2017	Industry	VR	HTC Vive, Unity 3D	–	Human robot collaboration in product engineering by VR
Bun <i>et al.</i> [58]	2017	Medical – Therapy	VR	3DS Max, EON Studio, nVisor MH60, Oculus Rift	20	To treat acrophobia using VR
Gasova <i>et al.</i> [30]	2017	Industry – Design	AR, VR	CERAA, Mobile	–	Ergonomic assessment in industrial environment
Masoni <i>et al.</i> [37]	2017	Industry – Maintenance	AR	AR Goggles, Tablet, Unity 3D, Vuforia	–	Provide a remote maintenance in industry 4.0 using AR
Eschen <i>et al.</i> [42]	2018	Aviation – Maintenance	AR, VR	Oculus Rift, Oculus SDK, OpenGL, Game controller, Microsoft HoloLens,	–	Detection of cracks in the maintenance of aircraft engines
Fazeli <i>et al.</i> [49]	2018	Medical – Analysis	VR	KUKA Robot Leap Motion Sensor, IR Camera, IR LED, Unity 3D	Case Study	Hand motion analysis using VR

(Continues)

Karvouniari <i>et al.</i> [29]	2018	Industry – Customization, Ergonomics	2	VR	CAVE, VICON Bonita 3, Markers, Wii Remotes, Unity 3D, RULA, REBA	–	2	VR-based decision tool for exoskeleton integration in industry
Scurati <i>et al.</i> [32]	2018	Industry – Maintenance	2	AR	Questionnaire, Unity 3D, Vuuforia, Mobile	–	2	Convey manuals into graphical symbols and use it in maintenance with AR
Shi <i>et al.</i> [50]	2018	Medical – Rehabilitation	2	VR	Kinect Sensor, Unity 3D, C#	–	2	VR-based user interface for the upper limb rehabilitation
Esfahlani <i>et al.</i> [51]	2018	Medical – Rehabilitation	2	VR	ReHabGame, Kinect, Myo Arm-band, Questionnaire	20	2	Rehab stroke patients using VR
Mourtzis <i>et al.</i> [36]	2018	Industry – Design, Training	2	AR	HoloLens, Unity 3D, CAD	100	2	Applying advanced visualization techniques in product design using AR
Wolfartsberger <i>et al.</i> [38]	2018	Industry – Maintenance	–	VR	Desktop PC (VR Ready), HTC Vive, Sensors, Controller, Unity 3D, 3DS Max	–	2	Implementation of a lightweight VR system in industrial engineering applications
Masood <i>et al.</i> [34]	2019	General – Manufacturing	–	AR	Questionnaire, 5-point Likert scale	365	2	Factors influencing the success of implementing AR in industry
Gattullo <i>et al.</i> [33]	2019	General – Maintenance	1	AR	iFixit, PDF, Unity 3D, Vuuforia, Questionnaire	22	1	Convert traditional text manuals to digital manuals in AR with compliance to Industry 4.0
Alarcon <i>et al.</i> [44]	2019	Aviation – Maintenance	1	AR	Questionnaire, 5-point Likert scale	56	1	AR application in space product assurance and safety activities
Ceruti <i>et al.</i> [43]	2019	Aviation – Maintenance, Manufacturing	1	AR	Game controller, Microsoft HoloLens, HoloLens clicker	–	1	Demonstrate that AR and AM are viable tools in aviation maintenance
Kwiatk <i>et al.</i> [47]	2019	Construction – Maintenance, Design	1	AR	Tablet, AR application	61	1	Impact of AR on assembly in construction
Wolfartsberger [35]	2019	Industry – Design	2	VR	HTC Vive, Unity 3D, 3DS Max	–	2	VR-based tool to support engineering design <i>(Continues)</i>

Table 4.1 (Continued)

Author	Year	Field	Technology	Tool	Sample	Objective
Perez <i>et al.</i> [41]	2019	Industry – Training	VR	KUKA KR500, Oculus Rift, HTC Vive, FARO Focus 3D, Blender	12	1 Replace the HMI directly with VR system which is connected with robot controller
Kopec <i>et al.</i> [53]	2019	2 Education – Training	VR	Proto.io, Epic Game's Unreal Engine, Unity Game Engine, HTC Vive, Matter View	4	Virtual ATM training for older adults
Garcia <i>et al.</i> [54]	2019	Education – Training	VR	Unity Pro, Raspberry Pi, Oculus Rift, FESTO lab	–	Achieve a virtual training environment to teach pneumatic systems in university students
Roldan <i>et al.</i> [55]	2019	Education – Training	VR	Unity Game Engine, SteamVR, HTC Vive, Questionnaire	20	Training for industry operators based on VR
Urbas <i>et al.</i> [31]	2019	Industry – Customization	AR	Bluetooth-enabled Vernier Caliper, HMD, HoloLens, Vuforia, Unity Game Engine	–	Transfer of product manufacturing information from a 3D model and display the graphical presentation in AR
Ferraguti <i>et al.</i> [26]	2019	Industry – Quality Control	AR	HoloLens, Mixed Reality Toolkit, Vuforia, Xbox Controller	–	AR in quality control
Mourtzis <i>et al.</i> [39]	2019	Industry – Design, Operation	AR	Enterprise Dynamics 10, 4D Script, QR Codes, Mobile GPS	–	Operate a warehouse using AR
Nguyen <i>et al.</i> [2]	2019	Medical – Surgery	AR	1 Tap to Place, HoloLens Cursor	27	AR-assisted surgery
Ibanez [52]	2020	Education – Training	AR	IMMS survey, Questionnaire, ARGeo	93	Impact of AR in students' academic achievement
Masood <i>et al.</i> [67]	2020	General – Manufacture	AR	Microsoft HoloLens, Unity, Questionnaire, TCT, TLX	11	AR implementation in industry
Nguyen <i>et al.</i> [57]	2020	Medical – Surgery	AR	AR Roadmap	240	2 CAN for pedicle screw insertion during spine surgery

Abbreviation: AM, additive manufacture; AR, augmented reality; BIM, building information modeling; CAD, computer aided design; CAN, computer-assisted navigation; CAVE, cave automatic virtual environment; CERAA, Ceit ergonomic analysis application; HMD, head mounted display; IMMS, instructional materials motivation survey; REBA, rapid entire body assessment; RULA, rapid upper limb assessment; SDK, software development kit; TCT, task completion time; TLX, task load index; VR, virtual reality; VSL, virtools scripting language



Unity game engine, which integrates motion / gesture capture, image processing, skeleton tracking, and IR emitter. Hardware components include only Microsoft Kinect and Thalmic Labs Mayo amband. Postural control, gestures, range of motion were tracked. ReHabGame include three main game designs: (i) reach grasp release, (ii) reach press hold, and (iii) reach press. Players reach, grasp, hold, and release virtual fruits in the virtual basket (Figure 4.11). This game involves flexion, extension, abduction, adduction, internal/external rotation, and horizontal abduction/adduction. Twenty stroke-affected patients participated in the study. Majority of the patients enjoyed the rehabilitation-based game and provided positive feedback.

Education is most important for all [68–74]. AR and VR outsmart the traditional black board and power point presentations. Irrespective of the age, AR and VR can be used to teach and train the young and old. AR is helpful for students' academic achievement [52]. VR is used in ATM training for older adults [53]. Virtual trainings are also provided to industrial operators [54,55]. A recent study developed a VR of mining process. Workers were trained and evaluated using questionnaire. A 2020 study used computer-assisted navigation (CAN) technique using AR Roadmap, Tap to Place, and HoloLens Cursor to perform spine surgery [56,57]. A VR-based study used Oculus Rift, nVisor MH60, EON Studio to treat acrophobia – the fear of height. Therapy is provided by developing a virtual high altitude scenario such as hill, tall building, and asking the patients to walk and cross the high altitude from one point to another [58]. Apart from industry, education, and medicine, AR and VR are used in other fields as well. Tourism [59,60], gaming [61], choreography [62], and customer satisfaction [63–65] are to name a few. The summary of this review is provided in Table 4.1.

### 4.3 Conclusion

This chapter assessed and reviewed the implementation of AR and VR in Industry 4.0. Researchers came up using low-cost devices and own algorithms rather than traditional commercial software such as CAVE, which cost more. Some papers proposed a conceptual theory, whereas others came up with quantitative and qualitative assessments. Their results suggest that AR and VR play a major role in minimizing the real-time decision-making and processing time. In industry-based setting, the utilization of AR and VR is more prominent. However, other than industry, the roots of AR and VR are not deep. Other fields such as education, tourism, and customer marketing have started to make use of AR and VR gradually, and it can be expected that eventually, the roots may deepen.

### References

- [1] A. Lele, "Industry 4.0," in *Disruptive Technologies for the Militaries and Security*, vol. 132, Singapore, Springer, 2019, pp. 205–215.
- [2] J. Morgan, "What is the fourth industrial revolution?," *Forbes*, 19 February 2016. [Online]. Available: <https://www.forbes.com/sites/jacobmorgan/2016/>

- 02/19/what-is-the-4th-industrial-revolution/#5738154ff392. [Accessed 24 January 2020].
- [3] The Boeing Center, "Industry 4.0: A brief history of automation and tech advancement," Olin Business School, 3 July 2017. [Online]. Available: <https://olinblog.wustl.edu/2017/07/industry-4-0-brief-history/>. [Accessed 24 January 2020].
- [4] H. S. Ning, and H. Liu, "Cyber-physical-social-thinking space based science and technology framework for the Internet of Things," *Science China Information Sciences*, vol. 58, pp. 1–19, 2015.
- [5] J. Cooper, and A. James, "Challenges for database management in the Internet of things," *IETE Technical Review*, vol. 26, no. 5, pp. 320–329, 2009.
- [6] T. M. Hessman, "The dawn of the smart factory," *Industry Week*, 14 February 2013. [Online]. Available: <https://www.industryweek.com/technology-and-iiot/article/21959512/the-dawn-of-the-smart-factory>. [Accessed 24 January 2020].
- [7] D. Kupper, "Embracing Industry 4.0 and rediscovering growth," [Online]. Available: <https://www.bcg.com/en-in/capabilities/operations/embracing-industry-4.0-rediscovering-growth.aspx>. [Accessed 24 January 2020].
- [8] M. Mikusz, "Towards an understanding of cyber-physical systems as industrial software-product-service system," *Procedia CIRP*, vol. 16, pp. 385–389, 2014.
- [9] S. Greengard, *The Internet of Things*, Boston: MIT Press, 2015.
- [10] M. Martin, *Building the Impact Economy*, Berlin: Springer, 2016.
- [11] M. James, "The internet of services in Industrie 4.0," *Concept Systems*, [Online]. Available: <https://conceptsystemsinc.com/the-internet-of-services-in-industrie-4-0/>. [Accessed 25 January 2020].
- [12] A. Javed, "IoT 2018: The three most important security trends," *Xorlogics*, 19 January 2018. [Online]. Available: <http://www.xorlogics.com/tag/internet-of-things/>. [Accessed 24 January 2020].
- [13] A. Yew, S. Ong, and A. Nee, "Towards a griddable distributed manufacturing system with augmented reality interfaces," *Robotics and Computer-Integrated Manufacturing*, vol. 39, pp. 43–55, 2016.
- [14] C. Fischer, M. Lusic, F. Faltus, R. Hornfeck, and J. Franke, "Enabling live data controlled manual assembly processes by worker information system and nearfield localization system," *Procedia CIRP*, vol. 55, pp. 242–247, 2016.
- [15] M. Demartini, F. Tonelli, L. Damiani, R. Revetria, and L. Cassettari, "Digitalization of manufacturing execution systems: The core technology for realizing future Smart Factories," in *XXII edition of the Summer School "Francesco Turco"*, 2017.
- [16] J. Yu, L. Fang, and C. Lu, "Key technology and application research on mobile augmented reality," in *7th IEEE International Conference on Software Engineering and Service Science*, 2016.
- [17] Z. Hong, and L. Wenhua, "Architecture and key techniques of augmented reality maintenance guiding system for civil aircrafts," *Journal of Physics: Conference Series*, vol. 787, no. 1, 2017.

- [18] H. Zhang, and S. Z. Yi, "Research on key technology of intelligent terminal navigation based on augmented reality," *Advanced Materials Research*, vol. 629, pp. 848–852, 2012.
- [19] Y. Wang, Y. Shen, D. Liu, S. Wei, and C. Zhu, "Key technique of assembly system in an augmented reality environment," in *2010 Second International Conference on Computer Modeling and Simulation*, 2010.
- [20] I. E. Sutherland, "A head-mounted three dimensional display," in *AFIPS '68 (Fall, part I)*, 1968.
- [21] A. Javornik, "'It's an illusion, but it looks real!' Consumer affective, cognitive and behavioural responses to augmented reality applications," *Journal of Marketing Management*, vol. 32, no. 9–10, pp. 987–1011, 2016.
- [22] M. Parveau, and M. Adda, "3iVClass: A new classification method for virtual, augmented and mixed realities," *Procedia Computer Science*, vol. 141, pp. 263–270, 2018.
- [23] D. A. Guttentag, "Virtual reality: Applications and implications for tourism," *Tourism Management*, vol. 31, no. 5, pp. 637–651, 2010.
- [24] M. Philips, "Augmented reality vs virtual reality vs mixed reality — An introductory guide," 21 October 2018. [Online]. Available: <https://uxplanet.org/augmented-reality-vs-virtual-reality-vs-mixed-reality-an-introductory-guide-5c3dce87bce0>.
- [25] L. Damiani, M. Demartini, G. Guizzi, R. Revetria, and F. Tonelli, "Augmented and virtual reality applications in industrial systems: A qualitative review towards the industry 4.0 era," *IFAC-PapersOnLine*, vol. 51, no. 11, pp. 624–630, 2018.
- [26] F. Ferraguti, F. Pini, T. Gale, *et al.*, "Augmented reality based approach for on-line quality assessment of polished surfaces," *Robotics and Computer Integrated Manufacturing*, vol. 59, pp. 158–167, 2019.
- [27] A. D. Giorgio, M. Romero, M. Onori, and L. Wang, "Human-machine collaboration in virtual reality for adaptive production engineering," in *27th International Conference on Flexible Automation and Intelligent Manufacturing*, Modena, 2017.
- [28] A. J. Morenilla, J. L. S. Romero, and F. S. Perez, "Augmented and virtual reality techniques for footwear," *Computers in Industry*, vol. 64, pp. 1371–1382, 2013.
- [29] A. Karvouniari, G. Michalos, N. Dimitropoulos, and S. Makris, "An approach for exoskeleton integration in manufacturing lines using virtual reality techniques," in *6th CIRP Global Web Conference*, 2018.
- [30] M. Gasova, M. Gaso, and A. Stefanik, "Advanced industrial tools of ergonomics based on Industry 4.0 concept," in *TRANSCOM 2017: International scientific conference on sustainable, modern and safe transport*, Zilina, 2017.
- [31] U. Urbas, R. Vrabic, and N. Vukasinovic, "Displaying product manufacturing information in augmented reality for inspection," in *52nd CIRP Conference on Manufacturing Systems*, 2019.
- [32] G. W. Scurati, M. Gattullo, M. Fiorentino, F. Ferrise, M. Bordegoni, and A. E. Uva, "Converting maintenance actions into standard symbols for



- augmented reality applications in Industry 4.0,” *Computers in Industry*, vol. 98, pp. 68–79, 2018.
- [33] M. Gattullo, G. W. Scurati, M. Fiorentino, A. E. Uva, F. Ferrise, and M. Bordegoni, “Towards augmented reality manuals for industry 4.0: A methodology,” *Robotics and Computer-Integrated Manufacturing*, vol. 56, pp. 276–286, 2019.
- [34] T. Masood and J. Egger, “Augmented reality in support of Industry 4.0 - Implementation challenges and success factors,” *Robotics and Computer Integrated Manufacturing*, vol. 58, pp. 181–195, 2019.
- [35] J. Wolfartsberger, “Analyzing the potential of virtual reality for engineering design review,” *Automation in Construction*, vol. 104, pp. 27–37, 2019.
- [36] D. Mourtzis, V. Zogopoulos, and E. Vlachou, “Augmented reality supported product design towards Industry 4.0: A teaching factory paradigm,” in *8th Conference on Learning Factories 2018 – Advanced Engineering Education & Training for*, 2018.
- [37] R. Masoni, F. Ferrise, M. Bordegoni, *et al.*, “Supporting remote maintenance in industry 4.0 through augmented reality,” in *27th International Conference on Flexible Automation and Intelligent Manufacturing*, Modena, 2017.
- [38] J. Wolfartsberger, J. Zenisek, and C. Sievi, “Chances and limitations of a virtual reality-supported tool for decision making in industrial engineering,” *IFAC PapersOnLine*, vol. 51, no. 11, pp. 637–642, 2018.
- [39] D. Mourtzis, V. Samothrakis, V. Zogopoulos, and E. Vlachou, “Warehouse design and operation using augmented reality technology: A papermaking industry case study,” in *12th CIRP Conference on Intelligent Computation in Manufacturing Engineering*, Gulf of Naples, 2019.
- [40] Z. Hui, “Head-mounted display-based intuitive virtual reality training system for the mining industry,” *International Journal of Mining Science and Technology*, vol. 27, pp. 717–722, 2017.
- [41] L. Perez, E. Diez, R. Usamentiaga, and D. F. Garcia, “Industrial robot control and operator training using virtual reality interfaces,” *Computers in Industry*, vol. 109, pp. 114–120, 2019.
- [42] H. Eschen, T. Kotter, R. Rodeck, M. Harnisch, and T. Schuppstuhl, “Augmented and virtual reality for inspection and maintenance processes in the aviation industry,” in *6th International Conference on Through-life Engineering Services 2017*, Bremen, 2018.
- [43] A. Ceruti, P. Marzocca, A. Liverani, and C. Bil, “Maintenance in aeronautics in an Industry 4.0 context: The role of augmented reality and additive manufacturing,” *Journal of Computational Design and Engineering*, vol. 6, pp. 516–526, 2019.
- [44] R. Alarcon, F. Wild, C. Perey, *et al.*, “Augmented reality for the enhancement of space product assurance and safety,” *Acta Astronautica*, vol. 168, pp. 191–199, 2019.
- [45] X. Wang, M. Truijens, L. Hou, Y. Wang, and Y. Zhou, “Integrating augmented reality with building information modeling: Onsite construction process

- controlling for liquefied natural gas industry,” *Automation in Construction*, vol. 40, pp. 96–105, 2014.
- [46] Z. Asgari, and F. P. Rahimian, “Advanced virtual reality applications and intelligent agents for construction process optimisation and defect prevention,” in *Creative Construction Conference 2017*, Primosten, 2017.
- [47] C. Kwiatek, M. Sharif, S. Li, C. Haas, and S. Walbridge, “Impact of augmented reality and spatial cognition on assembly in construction,” *Automation in Construction*, vol. 105, 2019.
- [48] J. Lee, S. Han, and J. Yang, “Construction of a computer-simulated mixed reality environment for virtual factory layout planning,” *Computers in Industry*, vol. 62, pp. 86–98, 2011.
- [49] H. R. Fazeli, S. K. Venkatesh, and Q. Peng, “A virtual environment for hand motion analysis,” in *6th CIRP Global Web Conference*, 2018.
- [50] Y. Shi, and Q. Peng, “A VR-based user interface for the upper limb rehabilitation,” in *6th CIRP Global Web Conference*, 2018.
- [51] S. S. Esfahlani, T. Thompson, A. D. Parsa, I. Brown, and S. Cirstea, “ReHabgame: A non-immersive virtual reality rehabilitation system with applications in neuroscience,” *Heliyon*, vol. 4, pp. 1–29, 2018.
- [52] M. B. Ibanez, A. U. Portillo, R. Z. Cabada, and M. L. Barron, “Impact of augmented reality technology on academic achievement and motivation of students from public and private Mexican schools. A case study in a middle-school geometry course,” *Computers & Education*, vol. 145, 2020.
- [53] W. Kopec, M. Wichrowski, K. Kalinowski, *et al.*, “VR with older adults: Participatory design of a virtual ATM training simulation,” *IFAC-PapersOnLine*, vol. 52, no. 19, pp. 277–281, 2019.
- [54] C. A. Garcia, G. Caiza, J. E. Naranjo, A. Ortiz, and M. V. Garcia, “An approach of training virtual environment for teaching electro-pneumatic systems,” *IFAC-PapersOnLine*, vol. 52, no. 9, pp. 278–284, 2019.
- [55] J. J. Roldan, E. Crespo, A. M. Barrio, E. P. Tapia, and A. Barrientos, “A training system for Industry 4.0 operators in complex assemblies based on virtual reality and process mining,” *Robotics and Computer-Integrated Manufacturing*, vol. 59, pp. 305–316, 2019.
- [56] N. Q. Nguyen, J. Cardinell, J. M. Ramjst, *et al.*, “An augmented reality system characterization of placement accuracy in neurosurgery,” *Journal of Clinical Neuroscience*, 2019.
- [57] N. Q. Nguyen, S. M. Priola, J. M. Ramjst, *et al.*, “Machine vision augmented reality for pedicle screw insertion during spine surgery,” *Journal of Clinical Neuroscience*, 2020.
- [58] P. Bun, F. Gorski, D. Grajewski, R. Wichniarek, and P. Zawadzki, “Low-cost devices used in virtual reality exposure therapy,” in *ICTE 2016*, Riga, 2017.
- [59] S. M. Correia Loureiro, J. Guerreiro, and F. Ali, “20 years of research on virtual reality and augmented reality in tourism context: A text-mining approach,” *Tourism Management*, vol. 77, 2020.

- [60] F. Serravalle, A. Ferraris, D. Vrontis, and A. Thrassou, "Augmented reality in the tourism industry: A multi-stakeholder analysis of museums," *Tourism Management Perspectives*, vol. 32, 2019.
- [61] L. L. Faican, and J. Jaen, "EmoFindAR: Evaluation of a mobile multiplayer augmented reality game for primary school children," *Computers & Education*, vol. 149, 2020.
- [62] T. J. Dube, and G. Ince, "A novel interface for generating choreography based on augmented reality," *International Journal of Human-Computer Studies*, vol. 132, pp. 12–24, 2019.
- [63] A. Rese, D. Baier, A. G. Schulz, and S. Schreiber, "How augmented reality apps are accepted by consumers: A comparative analysis using scales and opinions," *Technological Forecasting and Social Change*, vol. 124, pp. 306–319, 2017.
- [64] S. G. Dacko, "Enabling smart retail settings via mobile augmented reality shopping apps," *Technological Forecasting & Social Change*, vol. 124, pp. 243–256, 2017.
- [65] C. Flavian, I. S. Sanchez, and C. Orus, "The impact of virtual, augmented and mixed reality technologies on the customer experience," *Journal of Business Research*, vol. 100, pp. 574–560, 2019.
- [66] P. Fillatreau, J. Fourquet, R. Le Bolloch, S. Cailhol, A. Datas, and B. Puel, "Using virtual reality and 3D industrial numerical models for immersive interactive checklists," *Computers in Industry*, vol. 64, pp. 1253–1262, 2013.
- [67] T. Masood, and J. Egger, "Adopting augmented reality in the age of industrial digitalisation," *Computers in Industry*, vol. 115, 2020.
- [68] W. Y. Leong, and D. P. Mandic, "Towards adaptive blind extraction of post-nonlinearly mixed signals," *2006 16th IEEE Signal Processing Society Workshop on Machine Learning for Signal Processing*, IEEE, pp. 91–96, 2006.
- [69] S. Huang, D. H. Zhang, W. Y. Leong, *et al.*, "Detecting tool breakage using accelerometer in ball-nose end milling," *2008 10th International Conference on Control, Automation, Robotics and Vision*, IEEE, pp. 927–933, 2008.
- [70] W. Y. Leong, J. Homer, D. P. Mandic, "An implementation of nonlinear multiuser detection in Rayleigh fading channel," *EURASIP Journal on Wireless Communications and Networking (EURASIP JWCN)*, USA, Vol. 2006, pp. 1–9, 45647.
- [71] W. Y. Leong, and J. Homer, "Blind multiuser receiver in Rayleigh fading channel," *Australian Communications Theory Workshop (AusCTW'05)*, Brisbane, pp. 145–150, 2005.
- [72] E. B. T. Dennis, R. S. Tung, W. Y. Leong, and C. M. T. Joel, "Sleep disorder detection and identification," *Procedia engineering*, Elsevier, no. 41, pp. 289–295, 2012.
- [73] W. Y. Leong, "Implementing blind source separation in signal processing and telecommunications," *Thesis*, University of Queensland, Australia, 2005.
- [74] P. Mohankumar, and W. Y. Leong, "3D modelling with CT and MRI images of a scoliotic vertebrae," *Journal of Engineering Science and Technology EURECA*, pp. 188–198, 2015.



# Virtual augmented book chapter

ORIGINALITY REPORT

# 93%

SIMILARITY INDEX

## PRIMARY SOURCES

1	<a href="#">dokumen.pub</a> Internet	4110 words — 47%
2	Mohankumar Palaniswamy, Leong Wai Yie, Bhakti Yudho Suprpto. "Virtual and augmented reality in Industry 4.0", Institution of Engineering and Technology (IET), 2020 Crossref	1568 words — 18%
3	<a href="#">3lib.net</a> Internet	1286 words — 15%
4	"Front Matter", Institution of Engineering and Technology (IET), 2020 Crossref	1044 words — 12%
5	"The Nine Pillars of Technologies for Industry 4.0", Institution of Engineering and Technology (IET), 2020 Crossref	36 words — < 1%
6	<a href="#">digital-library.theiet.org</a> Internet	33 words — < 1%

EXCLUDE QUOTES ON

EXCLUDE SOURCES OFF

EXCLUDE BIBLIOGRAPHY ON

EXCLUDE MATCHES OFF